



# AVTECH ELECTROSYSTEMS LTD.

NANOSECOND WAVEFORM ELECTRONICS  
SINCE 1975

□ P.O. BOX 265  
OGDENSBURG, NY  
U.S.A. 13669-0265  
TEL: (315) 472-5270  
FAX: (613) 226-2802

TEL: 1-800-265-6681  
FAX: 1-800-561-1970

e-mail: [info@avtechpulse.com](mailto:info@avtechpulse.com)  
<http://www.avtechpulse.com>

□ P.O. BOX 5120 STN. F  
OTTAWA, ONTARIO  
CANADA K2C 3H4  
TEL: (613) 226-5772  
FAX: (613) 226-2802

## INSTRUCTIONS

### MODEL AVM-2-N-TERA2 PULSE GENERATOR

S.N.:

## WARRANTY

Avtech Electrosystems Ltd. warrants products of its manufacture to be free from defects in material and workmanship under conditions of normal use. If, within one year after delivery to the original owner, and after prepaid return by the original owner, this Avtech product is found to be defective, Avtech shall at its option repair or replace said defective item. This warranty does not apply to units which have been disassembled, modified or subjected to conditions exceeding the applicable specifications or ratings. This warranty is the extent of the obligation assumed by Avtech with respect to this product and no other warranty or guarantee is either expressed or implied.

## TECHNICAL SUPPORT

Phone: 613-226-5772 or 1-800-265-6681

Fax: 613-226-2802 or 1-800-561-1970

E-mail: [info@avtechpulse.com](mailto:info@avtechpulse.com)

World Wide Web: <http://www.avtechpulse.com>

TABLE OF CONTENTS

WARRANTY .....	2
FIG. 1: PULSE GENERATOR TEST ARRANGEMENT.....	4
GENERAL OPERATING INSTRUCTIONS.....	5
PERFORMANCE CHECK SHEET .....	7

Manual Reference: Q:\office\instructword\Avm\AVM-2-N-TERA2eda-fig.doc, created June 7, 2000

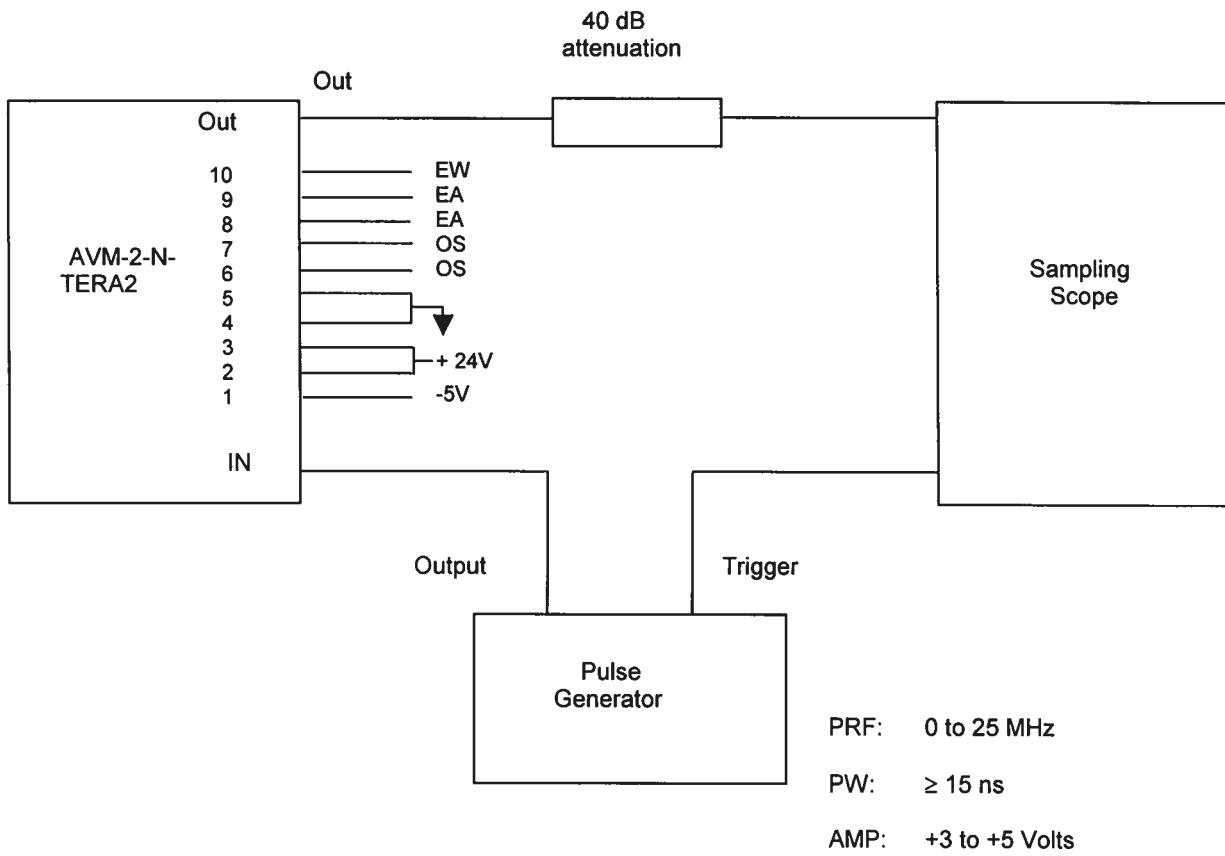
**FIG. 1: PULSE GENERATOR TEST ARRANGEMENT**

## GENERAL OPERATING INSTRUCTIONS

- 1) The bandwidth capability of components and instruments used to display the pulse generator output signal (attenuators, cables, connectors, etc.) should exceed ten gigahertz.
- 2) The use of 40db attenuator will insure a peak input signal to the sampling scope of less than one volt.
- 3) In general, the source pulse generator trigger delay control should be set in the 0.1 to 1.0 us range.
- 4) When testing using a general purpose 50 ohm laboratory pulse generator as the input trigger signal source, the input signal should be applied via a 50 ohm feed-through load or alternatively, the input to the AVM unit should be shunted with a 50 ohm resistor. This will prevent reflection (and degradation of the input pulse waveform) caused by the high impedance at the IN port. However, when triggering from a TTL source, no 50 ohm feed-through load or resistor is necessary but lead length should be as short as possible. High-speed TTL Schottky logic is recommended for the driving circuitry.
- 5) The input trigger pulse width should be greater than 15 ns and less than one half of the pulse repetition frequency period. The unit triggers on the leading edge of the input trigger signal.
- 6) The DC control voltages and the DC prime power supplies are applied to the unit via the amp 1-640441-0 connector (which is supplied along with a 59803-1 installation tool). The connector mates to 24 AWG.  
**CAUTION:** When connecting the connector to the chassis always insure that pin 1 on the connector aligns with and mates with pin 1 on the chassis. The unit may be damaged if this alignment is not achieved. Such damage is not covered by the warranty.
- 7) The DC prime power of +24VDC and -5V are respectively connected to pins 2,3 and to pin 1.
- 8) The output pulse width is controlled by means of 0 to +10 VDC applied to pin 10.
- 9) The output pulse amplitude is controlled by means of 0 to +10 VDC applied to pin 8 or 9. The pulse width may change by several nanoseconds as the output amplitude is reduced from maximum to minimum. Therefore it is convenient to first set the desired amplitude and then set the desired pulse width.

- 10) To DC offset the output pulse connect a DC power supply set to the required DC offset value pins 6 or 7. The maximum DC offset voltage is 50 volts (200 mA).
- 11) **WARNING:** Model AVM-2-N-TERA2 may fail if triggered at a PRF greater than 25.0 MHz.
- 12) The AVM unit requires a maximum prime input power of about 12 watts. It is therefore strongly recommended that the unit be heatsunk in order to maintain a moderate chassis temperature. The heat sink can be attached using the four 2-56 tapped holes on the bottom of the chassis. The four blind holes are tapped to at least 0.3 inches.
- 13) For additional assistance:  
  
Tel: 613-226-5772  
Fax: 613-226-2802  
Email: [info@avtechpulse.com](mailto:info@avtechpulse.com)

TOP VIEW

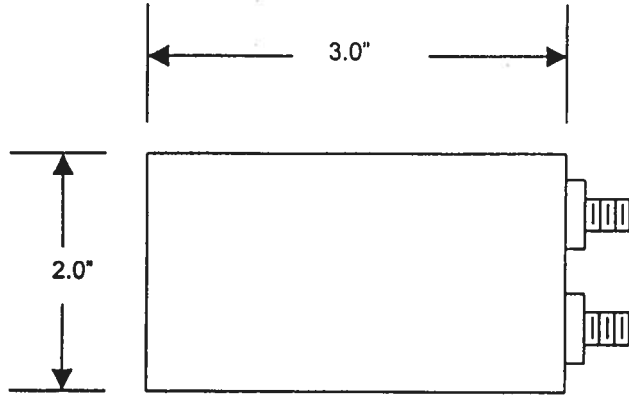

EDGE VIEW

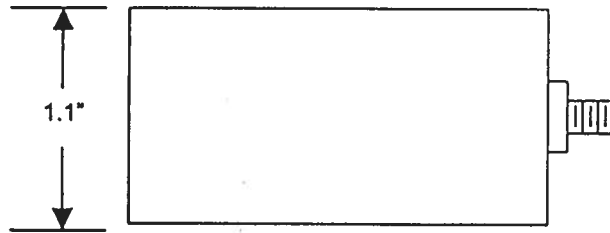

BOTTOM VIEW

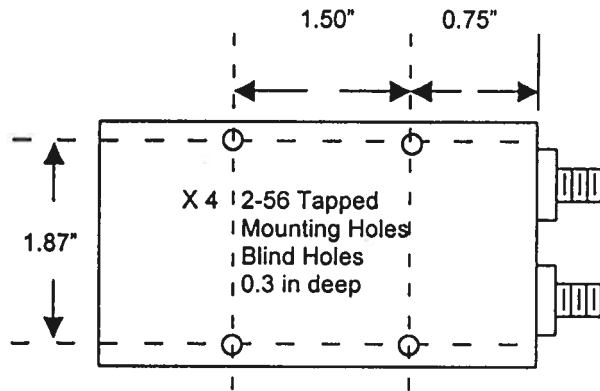

END VIEW

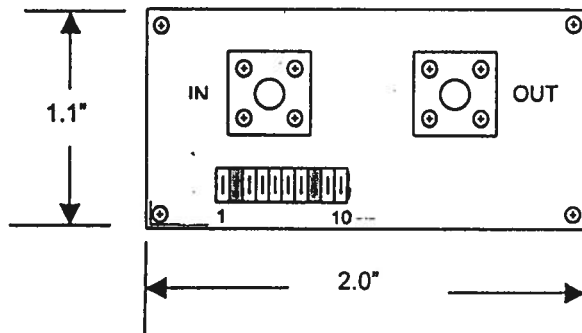

AVM-2-N-TERA2

IN: SMA  
 OUT: SMA  
 1: -5 VDC

2, 3: + 24 VDC  
 4, 5: GND  
 6, 7: OS  
 8: EA  
 9: EA  
 10: EW

April 10, 2000  
 MAY 1, 2000



# AVTECH ELECTROSYSTEMS LTD.

NANOSECOND WAVEFORM ELECTRONICS  
SINCE 1975

P.O. BOX 265  
OGDENSBURG, NY  
U.S.A. 13669-0265  
TEL: (315) 472-5270  
FAX: (613) 226-2802

TEL: 1-800-265-6681  
FAX: 1-800-561-1970

e-mail: [info@avtechpulse.com](mailto:info@avtechpulse.com)  
<http://www.avtechpulse.com>

P.O. BOX 5120 STN. F  
OTTAWA, ONTARIO  
CANADA K2C 3H4  
TEL: (613) 226-5772  
FAX: (613) 226-2802

Quote No: <u>9823</u>	Sender's Fax: <u>613-226-2802</u>
File: <u>R:\QUOTES\q9823.doc</u>	Receiver's Fax: <u>972-231-5963</u>
To: <u>Teradyne</u>	Receiver's Phone: <u>972-497-1254</u>
<u>Richardson, TX</u>	Date: <u>April 10, 2000</u>
Attn: <u>Dr. Bert Templeton</u>	Number of pages: <u>3, including cover</u>
Subject: <u>Price and delivery quotation</u>	

1) Following our telephone conversation of April 5, 2000, I am pleased to quote as follows:

Quote Number: 9823

Model Designation: AVM-2-N-TERA2

Output Pulse Parameters: As per standard AVM-2-N

Prime Power: +24 VDC, 500 mA, -5 VDC, 100 mA

Amplitude, Pulse Width Control: 0 to +10 VDC ( $R_{IN} > 1K$ )

Chassis Size: 1.1" x 2.0" x 3.0"

Chassis Material: Aluminum (sand-blasted)

Connectors: IN: SMA  
OUT: SMA  
+24VDC: } Ten 0.025" pins on 0.1" centers  
-5VDC: } to mate to AMP 1-640441-0  
OS: } connector (supplied). Connector  
EA: } mates to 24 AWG. Requires installation  
EW: } tool 59803-1 (one supplied). This connector is  
polarized and the chassis has mechanical guides,  
which prevent incorrect insertion into the chassis.

Price - Quantity of One: \$3,498.00 US, FOB destination.  
Price - Quantity of Two: \$2,998.00 US each, FOB destination  
Price - Quantity of Five: \$1,998.00 US each, FOB destination  
Price - Quantity of Ten: \$1,798.00 US each, FOB destination

Delivery: 30-45 days, after receipt of order.



- 2) Thank you for your continuing interest in our products. Please call me again if you require any additional information.

Regards,

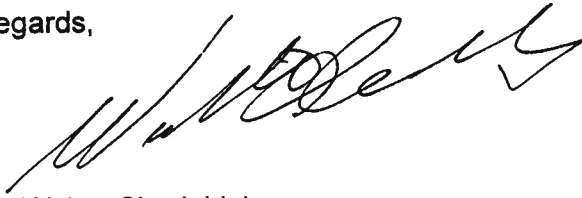
A handwritten signature in black ink, appearing to read 'W. Chudobiak', written in a cursive style.

Dr. Walter Chudobiak  
Chief Engineer

WC:mf