



AVTECH ELECTROSYSTEMS LTD.
NANOSECOND WAVEFORM ELECTRONICS

□ P.O. BOX 265
OGDENSBURG, NY
U.S.A. 13669-0265
TEL: (315) 472-5270
FAX: (613) 226-2802

☒ BOX 5120 STN. F
OTTAWA, ONTARIO
CANADA K2C 3H4
TEL: (613) 226-5772
FAX: (613) 226-2802

INSTRUCTIONS

MODEL AVM-C PULSE GENERATOR

S.N.:

WARRANTY

Avtech Electrosystems Ltd. warrants products of its manufacture to be free from defects in material and workmanship under conditions of normal use. If, within one year after delivery to the original owner, and after prepaid return by the original owner, this Avtech product is found to be defective, Avtech shall at its option repair or replace said defective item. This warranty does not apply to units which have been disassembled, modified or subjected to conditions exceeding the applicable specifications or ratings. This warranty is the extent of the obligation or liability assumed by Avtech with respect to this product and no other warranty or guarantee is either expressed or implied.

Fig. 1

PULSE GENERATOR TEST ARRANGEMENT

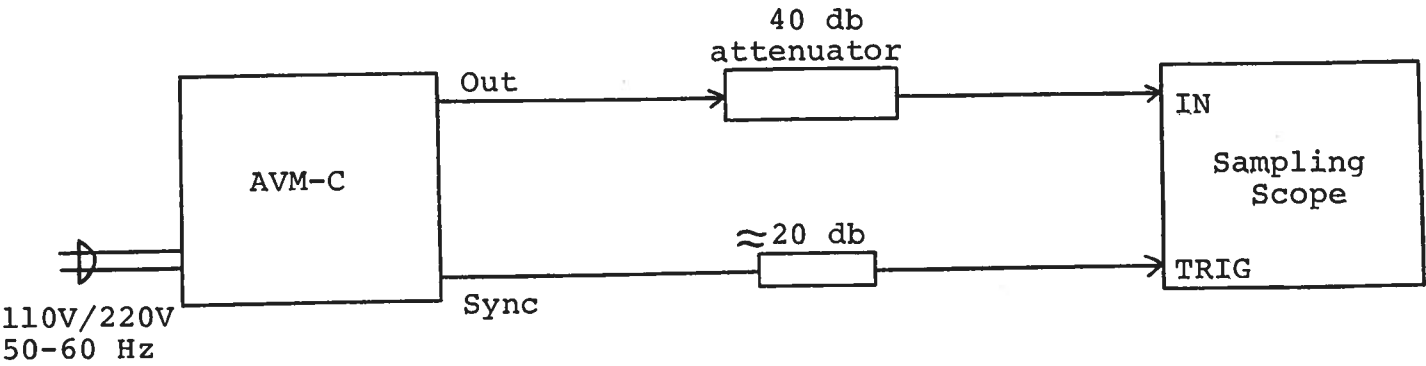

Notes:

- 1) The bandwidth capability of components and instruments used to display the pulse generator output signal (attenuators, cables, connectors, etc.) should exceed ten gigahertz.
- 2) The use of 40 db attenuator at the sampling scope vertical input channel will insure a peak input signal to the sampling scope of less than one volt.
- 3) The sync output channel provides a 0.2 volt 10 nsec pulse.
- 4) To obtain a stable output display the PRF and PRF FINE controls on the front panel should be set mid-range while the PRF range switch may be in either range. The front panel TRIG toggle switch should be in the INT position. The front panel DELAY control and the scope triggering controls are then adjusted to obtain a stable output. It is recommended that the DELAY control first be set max counter clockwise and then turned clockwise until a stable display is obtained. The scope may then be used to set the desired PRF by rotating the PRF and PRF FINE controls and by means of the PRF range switch. The stability of the display on some sampling scopes is very sensitive to the trigger delay setting, particularly at high PRF (eg. 10 to 25 MHz). If necessary, consult your sample scope instructions manual for the proper triggering method.
- 5) The output pulse width is controlled by means of the front panel one turn PW control. The control should initially be set maximum clockwise and the pulse width adjusted using an oscilloscope. Rotation of the PW pot causes the position of the falling edge of the pulse to change.
- 6) To voltage control the output pulse width, set the rear panel switch in the EXT position and apply 0 to +10V to connector A ($R_{IN} \geq 10K$). (EW option).
- 7) The output pulse amplitude is controlled by means of the front panel one turn AMP control. The pulse width may change by several nanoseconds as the output amplitude is reduced from maximum to minimum. Therefore it is convenient to first set the desired amplitude and then set the desired pulse width.
- 8) To voltage control the output amplitude, set the rear panel switch in the EXT position and apply 0 to +10V to connector B ($R_{IN} \geq 10K$). (EA option).

- 9) To DC offset the output pulse connect a DC power supply set to required DC offset value to the back panel terminals marked D.S. The maximum attainable DC offset voltage is ± 50 volts (for units without the OT or EO option only).
- 10) For units with the OT or EO options, the output DC offset is variable from +5 to -5 volts by means of the front panel one turn OFFSET control. The offset control may be turned off by means of the rear panel ON-OFF OFFSET switch.
- 11) For units with the EO option, the output offset may be voltage controlled by setting the rear panel switch in the EXT position and applying 0 to +10 volts to connector A ($R_{IN} \geq 10K$).
- 12) The AVM output pulse position or propagation delay can be varied for up to 5 nsec by means of the DELAY T_p control. Rotating the T_p control clockwise increases the delay. (-D option).
- 13) An external clock may be used to control the output PRF of the AVM unit by setting the front panel TRIG toggle switch in the EXT position and applying a 15 nsec (or wider) TTL level pulse to the TRIG BNC connector input. The AVM unit triggers on the rising edge of the input trigger pulse. For operation in this mode, the scope time base must also be triggered by the external clock rather than from the SYNC output.
- 14) WARNING: Model AVM-C may fail if triggered at a PRF greater than 25.0 MHz.
- 15) The Model AVM-C pulse generator can withstand an infinite VSWR on the output port.
- 16) Dual Polarity Option (for units without the OT or EO options).

To invert the output of the AVM unit, connect the AVX-2-T unit to the OUT port. An inverted pulse is then obtained at the OUT port of the AVX-2-T unit. To offset the inverted pulse, apply the required DC level to the DC terminal of the AVX-2-T unit.

- 17) Dual Polarity Option (for units with the OT or EO options).

To invert the output of the AVM unit, connect the AVX-2-T-OT unit to the OUT port. An inverted pulse with a rise time < 100 psec is then obtained at the OUT port of the AVX-2-T-OT unit. To offset the inverted pulse, connect a lead from the rear panel OS OUT banana plug to

the DC terminal of the AVX-2-T-OT unit. The DC offset at the output of the AVX-2-T-OT unit is then controlled by the front panel OFFSET control.

- 18) The AVM-C unit can be converted from 110 to 220V 50-60 Hz operation by adjusting the voltage selector card in the rear panel fused voltage selector-cable connector assembly.

Fig. 2

FRONT PANEL CONTROLS

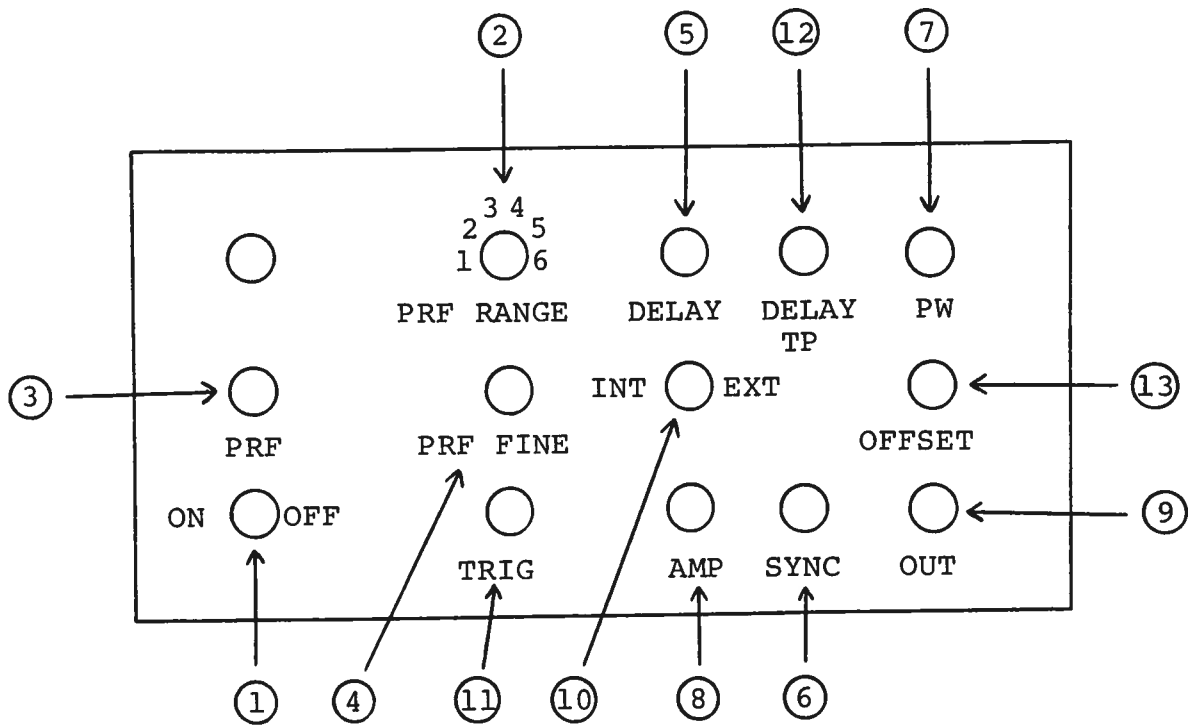

- (1) ON-OFF Switch. Applies basic prime power to all stages.
- (2) PRF Control. PRF RANGE, PRF and PRF FINE controls
- (3) determine output PRF as follows:
- (4)

	PRF MIN	PRF MAX
Range 1	10 KHz	50 KHz
Range 2	50 KHz	250 KHz
Range 3	185 KHz	650 KHz
Range 4	650 KHz	3.3 MHz
Range 5	3.3 MHz	13.3 MHz
Range 6	5.0 MHz	25 MHz

- (4) PRF FINE Control. This control varies PRF but is about 10 times less sensitive than the main PRF control.
- (5) DELAY Control. Controls the relative delay between the reference output pulse provided at the SYNC output (6) and the main output (9). This delay is variable over the range of 0 to at least 100 nsec.
- (6) SYNC Output. This output precedes the main output (9) and is used to trigger the sampling scope time base. The output is a 200 mV 10 nsec (approx) pulse capable of driving a fifty ohm load.
- (7) PW Control. A one turn control which varies the output pulse width.
- (8) AMP Control. A one turn control which varies the output pulse amplitude from 0 to max output to a fifty ohm load.
- (9) OUT Connector. SMA connector provides output to a fifty ohm load.
- (10) EXT-INT Control. With this toggle switch in the INT position, the PRF of the AVM unit is controlled via an internal clock which in turn is controlled by the PRF and PRF FINE controls. With the toggle switch in the EXT position, the AVM unit requires a 15 nsec (or wider) TTL level pulse applied at the TRIG input in order to trigger the output stages. In addition, in this mode, the scope time base must be triggered by the external trigger source.
- (11) TRIG Input. The external trigger signal is applied at this input when the EXT-INT toggle switch is in the EXT position.

- (12) DELAY TP (Option). A one turn control for varying the output pulse delay by 0 to 5 nsec.
- (13) OFFSET (option). A one turn control for varying the output DC offset from -5 to +5 volts.

Fig. 4

BACK PANEL CONTROLS (for units with the OT or EO options)

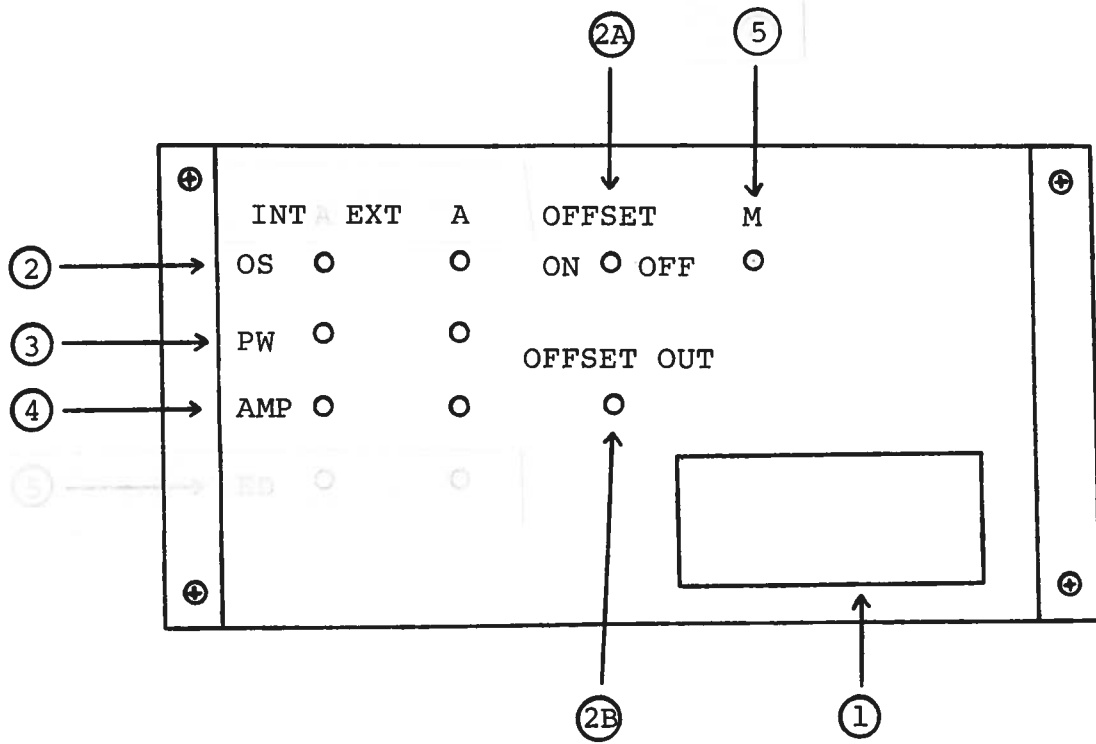

- (1) FUSED CONNECTOR, VOLTAGE SELECTOR. The detachable power cord is connected at this point. In addition, the removable cord is adjusted to select the desired input operating voltage. The unit also contains the main power fuse.
- (2) To voltage control the output DC offset, set the switch in the EXT position and apply 0 to +10V to connector A ($R_{IN} \geq 10K$). (EO option).
- (2A) Two position switch which turns output DC offset ON or OFF. (EO or OT options).
- (2B) With OFFSET ON-OFF switch in ON position, DC output offset potential appears at this terminal. To offset inverted pulse on AVM units with dual polarity option (-PN) connect this terminal to the DC terminal of the AVX-2-T-OT module. (EO or OT options).
- (3) To voltage control the output pulse width, set the switch in the EXT position and apply 0 to +10V to connector A ($R_{IN} \geq 10K$). (EW option).
- (4) To voltage control the output amplitude, set the switch in the EXT position and apply 0 to +10V to connector A ($R_{IN} \geq 10K$). (EA option).
- (5) MONITOR Output. Provides an attenuated (x10) coincident replica (to 50 ohm) of the main output. (option).

Fig. 5

SYSTEM BLOCK DIAGRAM (WITHOUT EA, EW, ED OPTIONS)

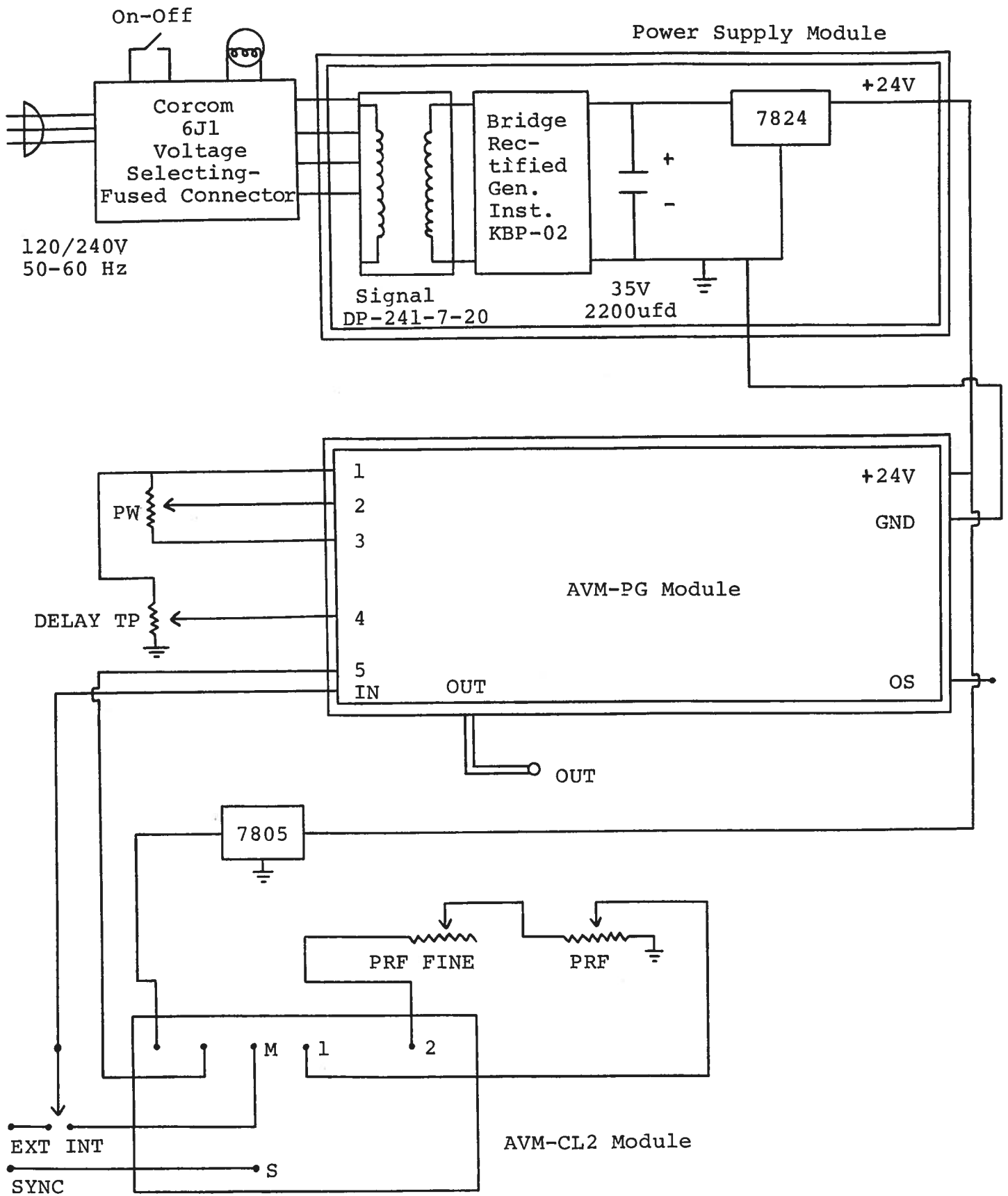
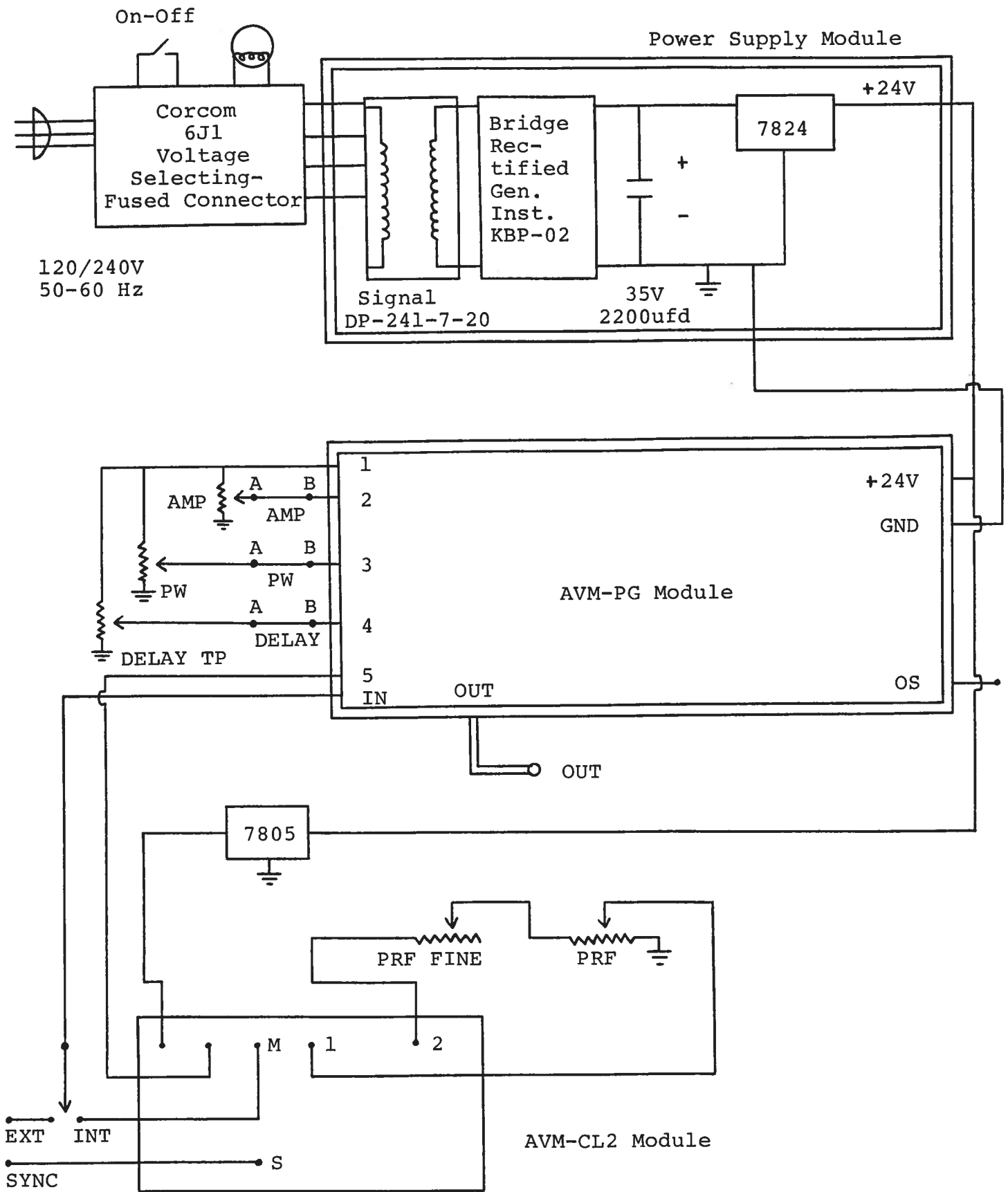

Fig. 6

SYSTEM BLOCK DIAGRAM (WITH EA, EW, ED OPTIONS)



SYSTEM DESCRIPTION AND REPAIR PROCEDURE

The AVM-C consists of a pulse generator module (AVM-PG), a clock module (AVM-CL) and a power supply board which supplies +24 volts (600 mA max) to the pulse generator module. In the event that the unit malfunctions, remove the instrument cover by removing the four Phillips screws on the back panel of the unit. The top cover may then be slid off. Measure the voltage at the +24 V pin of the PG module. If this voltage is substantially less than +24 volts, unsolder the line connecting the power supply and PG modules and connect 50 ohm 10 W load to the PS output. The voltage across this load should be about +24 V DC. If this voltage is substantially less than 24 volts the PS module is defective and should be repaired or replaced. If the voltage across the resistor is near 24 volts, then the PG module should be replaced or repaired. The sealed PG module must be returned to Avtech for repair (or replacement). The clock module provides a 20 nsec TTL level trigger pulse at pin M to trigger the PG module and a 20 nsec 0.5 V sync pulse at pin S to trigger the sampling scope display device. The output at pin S precedes the output at pin M by 0 to 100 nsec depending on the DELAY control setting. With the INT-EXT switch in the EXT position, the clock module is disconnected from the PG module. The clock module is functioning properly if:

- a) 10 nsec, or wider, outputs are observed at pins M and S.
- b) The PRF of the outputs can be varied over the range of 10 KHz to 25 MHz using the PRF, PRF FINE and PRF RANGE controls.
- c) The relative delay between the pin M and S outputs can be varied by at least 100 nsec by the DELAY control.

The sealed clock module must be returned to Avtech for repair or replacement if the above conditions are not observed.

Schroff

11.27.90

Edition C

-EW

-ER

-OS

-OT

-EO

-D

-PN

-M