



AVTECH ELECTROSYSTEMS LTD.

NANOSECOND WAVEFORM ELECTRONICS
SINCE 1975

□ P.O. BOX 265
OGDENSBURG, NY
U.S.A. 13669-0265
TEL: (315) 472-5270
FAX: (613) 226-2802

TEL: 1-800-265-6681
FAX: 1-800-561-1970
U.S.A. & CANADA

☒ BOX 5120 STN. F
OTTAWA, ONTARIO
CANADA K2C 3H4
TEL: (613) 226-5772
FAX: (613) 226-2802

INSTRUCTIONS

MODEL AVM-PS-IP PULSE GENERATOR

S.N. :

WARRANTY

Avtech Electrosystems Ltd. warrants products of its manufacture to be free from defects in material and workmanship under conditions of normal use. If, within one year after delivery to the original owner, and after prepaid return by the original owner, this Avtech product is found to be defective, Avtech shall at its option repair or replace said defective item. This warranty does not apply to units which have been disassembled, modified or subjected to conditions exceeding the applicable specifications or ratings. This warranty is the extent of the obligation or liability assumed by Avtech with respect to this product and no other warranty or guarantee is either expressed or implied.

MODEL AVM-PS-IP PULSE GENERATOR TEST ARRANGEMENT

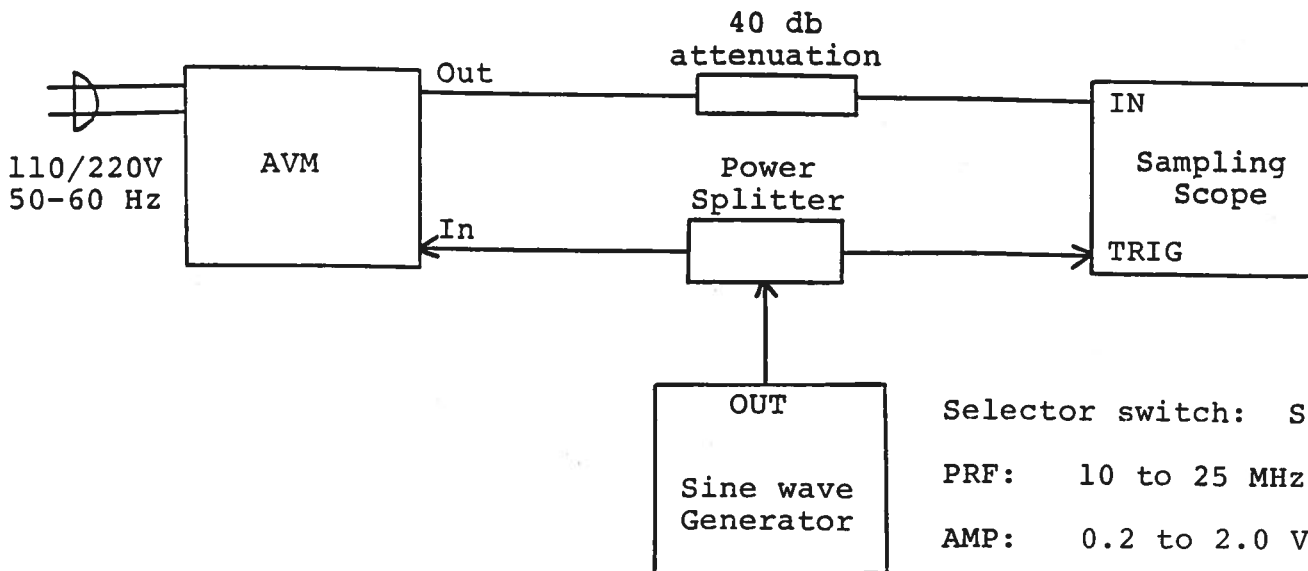

Selector switch: SINE

PRF: 10 to 25 MHz

AMP: 0.2 to 2.0 VRMS

NOTE:

For testing with a TTL source, apply a 15 ns or wider pulse, +3 to +5 Volts. PRF 0 to 25 MHz (and place the selector switch in the TTL position and trigger the scope from the SYNC out delay of the lab pulse generator). Do not use the power splitter when testing with a TTL source.

Notes:

- 1) The bandwidth capability of components and instruments used to display the pulse generator output signal (attenuators, cables, connectors, etc.) should exceed ten gigahertz.
- 2) The use of 40 dB attenuator will insure a peak input signal to the sampling scope of less than one Volt.
- 3) When testing with a sine wave source, set the selector switch in the SINE position and apply a 0.2 to 2.0 Volt (RMS) sine wave (10-25 MHz) to the IN BNC. A power splitter may be used to provide a trigger signal for the scope time base. Note that the scope time base controls must be carefully adjusted to obtain a stable display, particularly at the lower PRF (eg. 10 MHz).
- 4) When testing with a TTL input pulse, place the selector switch in the TTL position and the source pulse generator trigger delay control should be set in the 0.1 to 1.0 us range. The stability of the display on some sampling scopes is very sensitive to this delay, particularly at high PRF (eg. 10 to 25 MHz). If necessary, consult your sample scope instructions manual for the proper triggering method. The input trigger pulse width should be greater than 15 ns and less than one half of the pulse repetition frequency period. The unit triggers on the leading edge of the input trigger signal.
- 5) The output pulse width is controlled by means of the one-turn potentiometer (PW). The pot should initially be set maximum clockwise and the pulse width adjusted using an oscilloscope.
- 6) The output pulse amplitude is controlled by means of the one-turn potentiometer (AMP). The pulse width may change by several nanoseconds as the output amplitude is reduced from maximum to minimum. Therefore it is convenient to first set the desired amplitude and then set the desired pulse width. Rotation of the PW pot causes the position of the falling edge of the pulse to change.
- 7) To voltage control the output pulse width, set the rear panel switch in the EXT position and apply 0 to +10V to connector A ($R_{IN} \geq 10K$). (EW option).

- 8) To voltage control the output amplitude, set the rear panel switch in the EXT position and apply 0 to +10V to connector A ($R_{IN} \geq 10K$). (EA option).
- 9) Some properties of the output pulse may change as a function of the amplitude pot setting. For some demanding applications, it may be desirable to use a combination of external attenuators and the amplitude pot to achieve the desired output amplitude.
- 10) The AVM output pulse position or delay can be varied for up to 5 ns by means of the delay (DELAY) control. Rotating the delay control clockwise increases the delay. If the full 5 ns delay cannot be achieved then the input pulse width should be increased by a few nanoseconds. (option).
- 11) WARNING: Model AVM-PS may fail if triggered at a PRF greater than 25.0 MHz.
- 12) The Model AVM-PS pulse generator can withstand an infinite VSWR on the output port.
- 13) For units with the OT offset option, the output DC offset level is varied from -5 to +5V (to 50 Ohm) by the front panel OFFSET one turn control. The DC offset may be turned off using the rear panel OS ON-OFF toggle switch. (OT option).
- 14) For units with the EO option, the output offset may be voltage controlled by setting the rear panel switch in the EXT position and applying 0 to +10 Volts to connector A ($R_{IN} \geq 10K$).
- 15) To invert the output of the AVM unit, connect the AVX-2-T unit to the OUT port. An inverted pulse is then obtained at the OUT port of the AVX-2-T unit. To offset the inverted pulse, apply the required DC level to the DC terminal of the AVX-2-T unit.
- 16) MONITOR Output. Provides an attenuated (x10) coincident replica (to 50 Ohm) of the main output. (option).
- 17) The unit can be converted from 110 to 220V 50-60 Hz operation by adjusting the voltage selector card in the rear panel fused voltage selector cable connector assembly.
- 18) For additional assistance:

Tel: (613) 226-5772
Fax: (613) 226-2802

SYSTEM BLOCK DIAGRAM AND REPAIR PROCEDURE

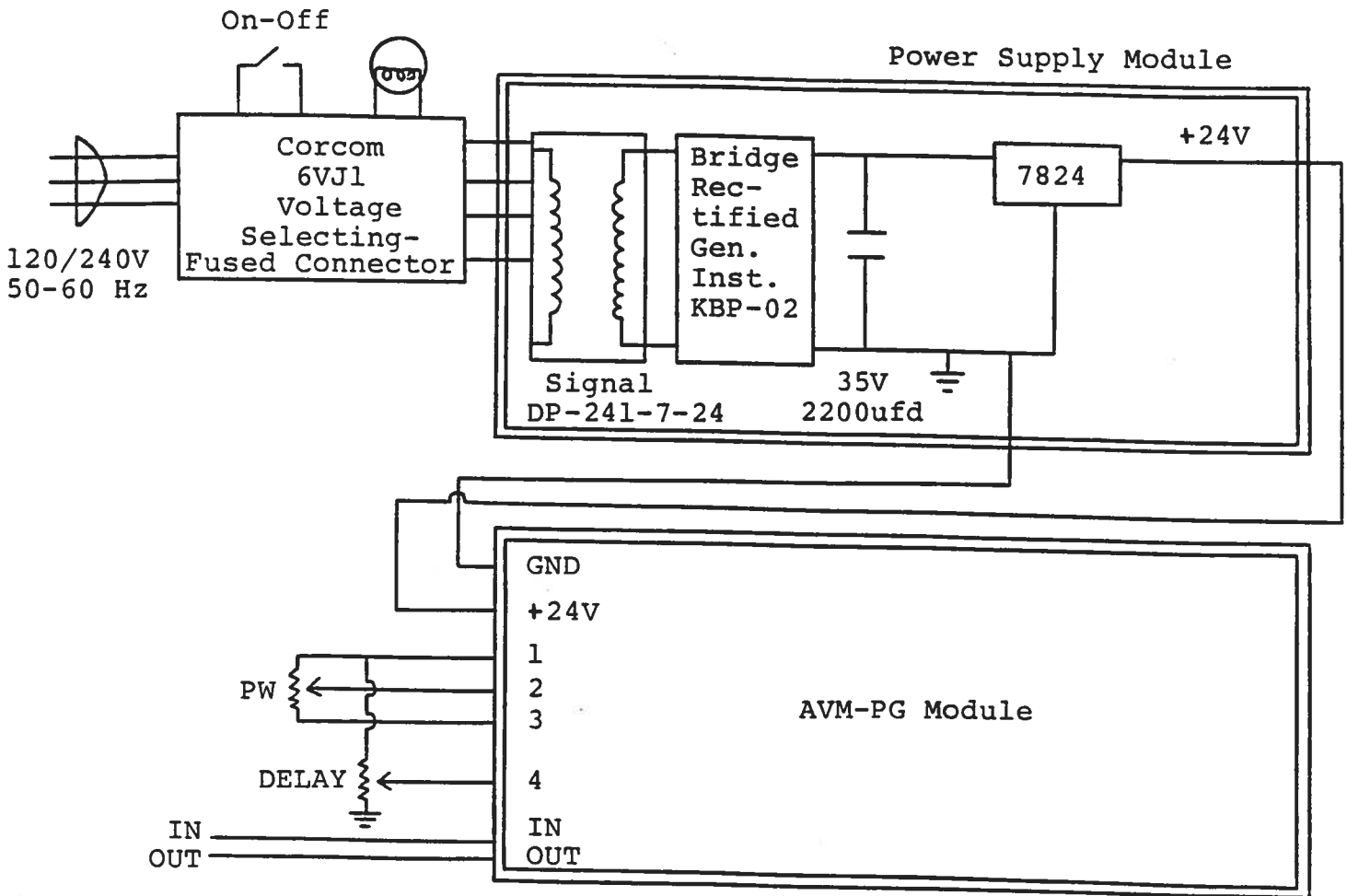

SYSTEM DESCRIPTION AND REPAIR PROCEDURE

The AVM-2-PS consists of a pulse generator module (AVM-2-PS-PG) and a power supply board which supplies +24 Volts (600 mA max) to the pulse generator module. In the event that the AVM-PS unit malfunctions, remove the instrument cover by removing the four Phillips screws on the back of the unit. The top lid may then be slid off. Measure the voltage at the +24V pin of the PG module. If this voltage is substantially less than +24 Volts, unsolder the line connecting the power supply and PG modules and connect 50 Ohm 10 W load to the PS output. The voltage across this load should be about +24 V DC. If this voltage is substantially less than 24 Volts the PS module is defective and should be repaired or replaced. If the voltage across the resistor is near 24 Volts, then the PG module should be replaced or repaired. The sealed PG module must be returned to Avtech for repair (or replacement).

Jan. 3/95

edition B

-EW

-EA

-OT

-EO

-M

Disk: AVM

Name: PSIPEDB.INS