



AVTECH ELECTROSYSTEMS LTD.

NANOSECOND WAVEFORM ELECTRONICS
SINCE 1975

□ P. O. BOX 265
OGDENSBURG, NY
U.S.A. 13669-0265
TEL: (315) 472-5270
FAX: (613) 226-2802

TEL: 1-800-265-6681
FAX: 1-800-561-1970
U.S.A. & CANADA

e-mail: info@avtechpulse.com

✕ BOX 5120 STN. F
OTTAWA, ONTARIO
CANADA K2C 3H4
TEL: (613) 226-5772
FAX: (613) 226-2802

INSTRUCTIONS

MODEL AVM-2-EW PULSE GENERATOR

S.N. :

WARRANTY

Avtech Electrosystems Ltd. warrants products of its manufacture to be free from defects in material and workmanship under conditions of normal use. If, within one year after delivery to the original owner, and after prepaid return by the original owner, this Avtech product is found to be defective, Avtech shall at its option repair or replace said defective item. This warranty does not apply to units which have been disassembled, modified or subjected to conditions exceeding the applicable specifications or ratings. This warranty is the extent of the obligation or liability assumed by Avtech with respect to this product and no other warranty or guarantee is either expressed or implied.

MODEL AVM PULSE GENERATOR TEST ARRANGEMENT

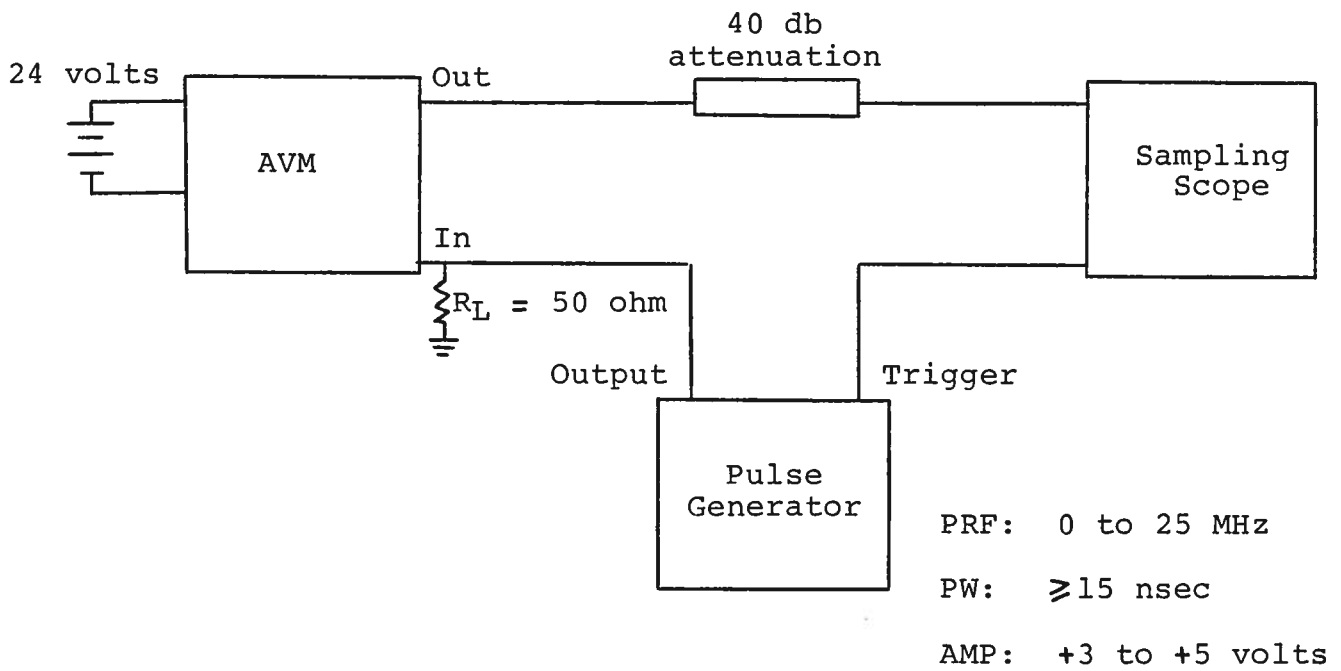

Notes:

- 1) The bandwidth capability of components and instruments used to display the pulse generator output signal (attenuators, cables, connectors, etc.) should exceed ten gigahertz.
- 2) The use of 40 db attenuator will insure a peak input signal to the sampling scope of less than one volt.
- 3) In general, the source pulse generator trigger delay control should be set in the 0.1 to 1.0 usec range.*
- 4) When testing using a general purpose 50 ohm laboratory pulse generator as the input trigger signal source, the input signal should be applied via a 50 ohm feed-through load or alternatively, the input to the AVM unit should be shunted with a 50 ohm resistor. This will prevent reflection (and degradation of the input pulse waveform) caused by the high impedance at the IN port. However, when triggering from a TTL source, no 50 ohm feed-through load or resistor is necessary but lead length should be as short as possible. High-speed TTL Schottky logic is recommended for the driving circuitry.
- 5) The input trigger pulse width should be greater than 15 nsec and less than one half of the pulse repetition frequency period. The unit triggers on the leading edge of the input trigger signal.
- 6) The output amplitude is controlled by the one turn AMP control.
- 7) The output pulse width (0 to 2 nsec) is controlled by a DC voltage (0 to +10V, $R_{IN} \gg 10K$) applied to the PW solder terminals.
- 8) The output amplitude pulse width and PRF are inter-related. It is recommended that the following sequence be used:
 - a) Set PRF
 - b) Set output amplitude
 - c) Set pulse width
- 9) **WARNING:** Model AVM-2 may fail if triggered at a PRF greater than 25.0 MHz.
- 10) The Model AVM-2 pulse generator can withstand an infinite VSWR on the output port.
- 11) The AVM unit requires a maximum prime input power of about 12 watts. It is therefore strongly recommended that the unit be heatsunk in order to maintain a moderate chassis temperature.

- 12) To DC offset the output pulse connect a DC power supply set to the required DC offset value to the terminals marked O.S. The maximum attainable DC offset voltage is 50 volts.
- * The stability of the display on some sampling scopes is very sensitive to this delay, particularly at high PRF (eg. 10 to 25 MHz). If necessary, consult your sample scope instructions manual for the proper triggering method.

