



AVTECH ELECTROSYSTEMS LTD.

NANOSECOND WAVEFORM ELECTRONICS
SINCE 1975

□ P.O. BOX 265
OGDENSBURG, NY
U.S.A. 13669-0265
TEL: (315) 472-5270
FAX: (613) 226-2802

TEL: 1-800-265-6681
FAX: 1-800-561-1970

e-mail: info@avtechpulse.com
<http://www.avtechpulse.com>

□ P.O. BOX 5120 STN. F
OTTAWA, ONTARIO
CANADA K2C 3H4
TEL: (613) 226-5772
FAX: (613) 226-2802

INSTRUCTIONS

MODEL AVMH-2-C-M-PN PULSE GENERATOR

S.N.:

WARRANTY

Avtech Electrosystems Ltd. warrants products of its manufacture to be free from defects in material and workmanship under conditions of normal use. If, within one year after delivery to the original owner, and after prepaid return by the original owner, this Avtech product is found to be defective, Avtech shall at its option repair or replace said defective item. This warranty does not apply to units which have been disassembled, modified or subjected to conditions exceeding the applicable specifications or ratings. This warranty is the extent of the obligation assumed by Avtech with respect to this product and no other warranty or guarantee is either expressed or implied.

TECHNICAL SUPPORT

Phone: 613-226-5772 or 1-800-265-6681

Fax: 613-226-2802 or 1-800-561-1970

E-mail: info@avtechpulse.com

World Wide Web: <http://www.avtechpulse.com>

TABLE OF CONTENTS

WARRANTY.....	2
TABLE OF CONTENTS	3
FIG. 1: PULSE GENERATOR TEST ARRANGEMENT.....	4
GENERAL OPERATING INSTRUCTIONS	5
FIG. 2: FRONT PANEL CONTROLS	7
FRONT PANEL CONTROLS	8
FIG. 3: BACK PANEL CONTROLS.....	9
BACK PANEL CONTROLS.....	10
FIG. 4: SYSTEM BLOCK DIAGRAM.....	11
SYSTEM DESCRIPTION AND REPAIR PROCEDURE	12
POWER SUPPLY AND FUSE REPLACEMENT.....	13
PERFORMANCE CHECK SHEET	15

FIG. 1: PULSE GENERATOR TEST ARRANGEMENT

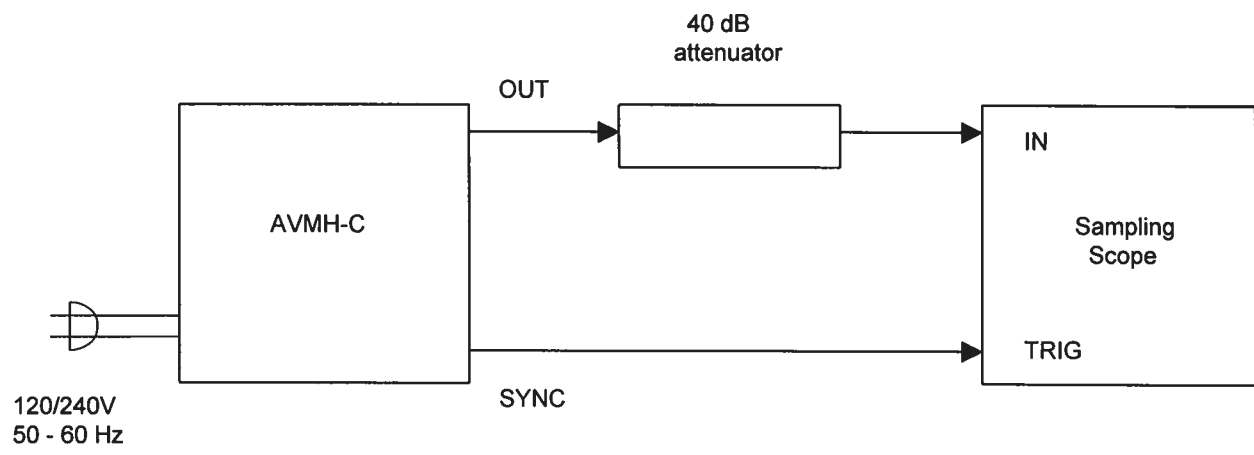

GENERAL OPERATING INSTRUCTIONS

- 1) The bandwidth capability of components and instruments used to display the pulse generator output signal (attenuators, cables, connectors, etc.) should exceed ten gigahertz.
- 2) The use of 40 dB attenuator at the sampling scope vertical input channel will insure a peak input signal to the sampling scope of less than one Volt.
- 3) The sync output channel provides a 0.2 Volt 10 ns pulse.
- 4) To obtain a stable output display the PRF and PRF FINE controls on the front panel should be set mid-range while the PRF range switch may be in either range. The front panel TRIG toggle switch should be in the INT position. The front panel DELAY control and the scope triggering controls are then adjusted to obtain a stable output. It is recommended that the DELAY control first be set max counter clockwise and then turned clockwise until a stable display is obtained. The scope may then be used to set the desired PRF by rotating the PRF and PRF FINE controls and by means of the PRF range switch. The stability of the display on some sampling scopes is very sensitive to the trigger delay setting, particularly at high PRF (eg. 10 to 25 MHz). If necessary, consult your sample scope instructions manual for the proper triggering method.
- 5) The output pulse width is controlled by means of the one turn T_R and T_F controls. The T_R control controls the position of the leading edge while the T_F control determines the position of the falling edge. Clockwise rotation of these controls causes the pulse edge to move to the right. It is necessary to sequentially adjust the T_R , T_F and AMP controls to obtain the desired output pulse width and amplitude.
- 6) The output pulse amplitude is controlled by means of the front panel one turn AMP control. The pulse width may change by several nanoseconds as the output amplitude is reduced from maximum to minimum. Therefore it is convenient to first set the desired amplitude and then set the desired pulse width as described above.

- 7) An external clock may be used to control the output PRF of the AVMH unit by setting the front panel TRIG toggle switch in the EXT position and applying a 15 ns (or wider) TTL level pulse to the TRIG BNC connector input. The AVMH unit triggers on the rising edge of the input trigger pulse. For operation in this mode, the scope time base must also be triggered by the external clock rather than from the SYNC output.
- 8) WARNING: Model AVMH-C may fail if triggered at a PRF greater than 25.0 MHz.
- 9) The Model AVMH-C pulse generator can withstand an infinite VSWR on the output port.
- 10) To invert the output of the AVMH unit, connect the AVX-2 unit to the OUT port. An inverted pulse is then obtained at the OUT port of the AVX-2 unit.
- 11) The AVMH-C unit can be converted from 120 to 240V 50-60 Hz operation by adjusting the voltage selector card in the rear panel fused voltage selector-cable connector assembly.
- 12) For additional assistance:

Tel: (613) 226-5772

Fax: (613) 226-2802

Email: info@avtechpulse.com

FIG. 2: FRONT PANEL CONTROLS

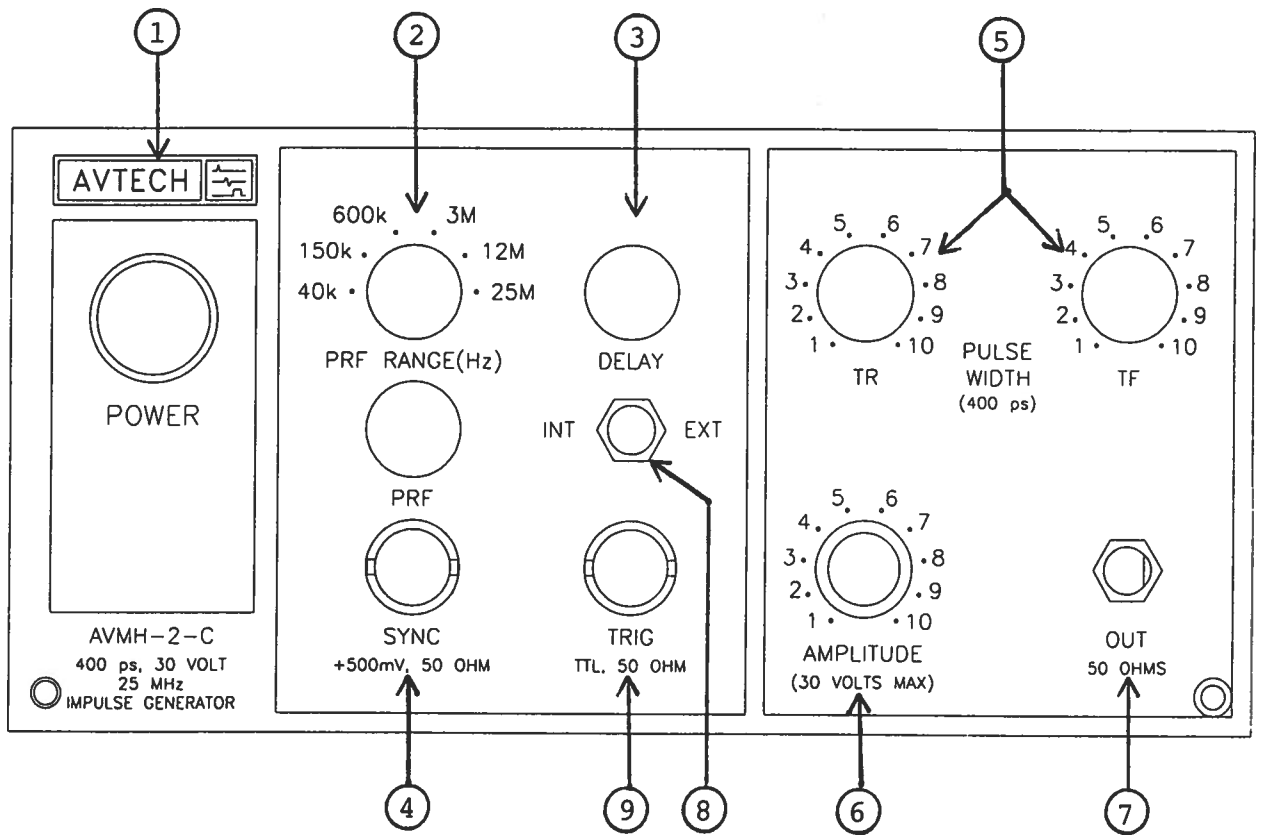

FRONT PANEL CONTROLS

- (1) ON-OFF Switch. Applies basic prime power to all stages.
- (2) PRF Control. PRF RANGE and PRF controls determine output PRF as follows:

	PRF MIN	PRF MAX
Range 1	10 kHz	50 kHz
Range 2	50 kHz	250 kHz
Range 3	185 kHz	650 kHz
Range 4	650 kHz	3.3 MHz
Range 5	3.3 MHz	13.3 MHz
Range 6	5.0 MHz	25 MHz

- (3) DELAY Control. Controls the relative delay between the reference output pulse provided at the SYNC output (4) and the main output (7). This delay is variable over the range of 0 to at least 100 ns.
- (4) SYNC Output. This output precedes the main output (7) and is used to trigger the sampling scope time base. The output is a 200 mV 10 ns (approx) pulse capable of driving a fifty Ohm load.
- (5) PW Control. Two one turn controls, which varies the output pulse width. TR determines the position of the rising edge while TF determines the position of the falling edge.
- (6) AMP Control. A one turn control, which varies the output pulse amplitude from 0 to max output to a fifty Ohm load.
- (7) OUT Connector. SMA connector provides output to a fifty Ohm load.
- (8) EXT-INT Control. With this toggle switch in the INT position, the PRF of the AVMH unit is controlled via an internal clock, which in turn is controlled by the PRF controls. With the toggle switch in the EXT position, the AVMH unit requires a 15 ns (or wider) TTL level pulse applied at the TRIG input in order to trigger the output stages. In addition, in this mode, the scope time base must be triggered by the external trigger source.
- (9) TRIG Input. The external trigger signal is applied at this input when the EXT-INT toggle switch is in the EXT position.

FIG. 3: BACK PANEL CONTROLS

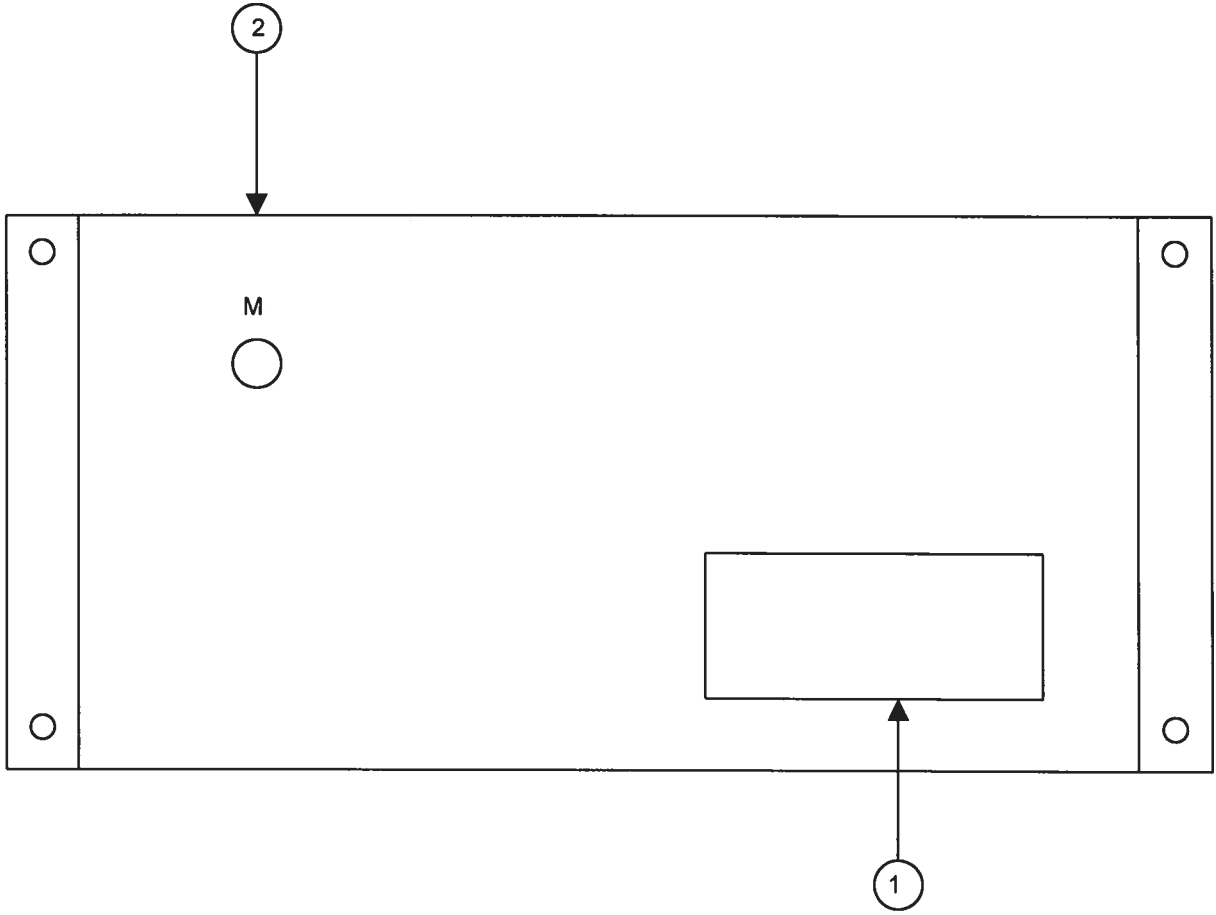

BACK PANEL CONTROLS

- (1) FUSED CONNECTOR, VOLTAGE SELECTOR. The detachable power cord is connected at this point. In addition, the removable cord is adjusted to select the desired input operating voltage. The unit also contains the main power fuse (0.5A SB).
- (2) MONITOR OUTPUT. Provides an attenuated (x10) coincident replica (to 50 Ohm) of the main output. (option)

FIG. 4: SYSTEM BLOCK DIAGRAM

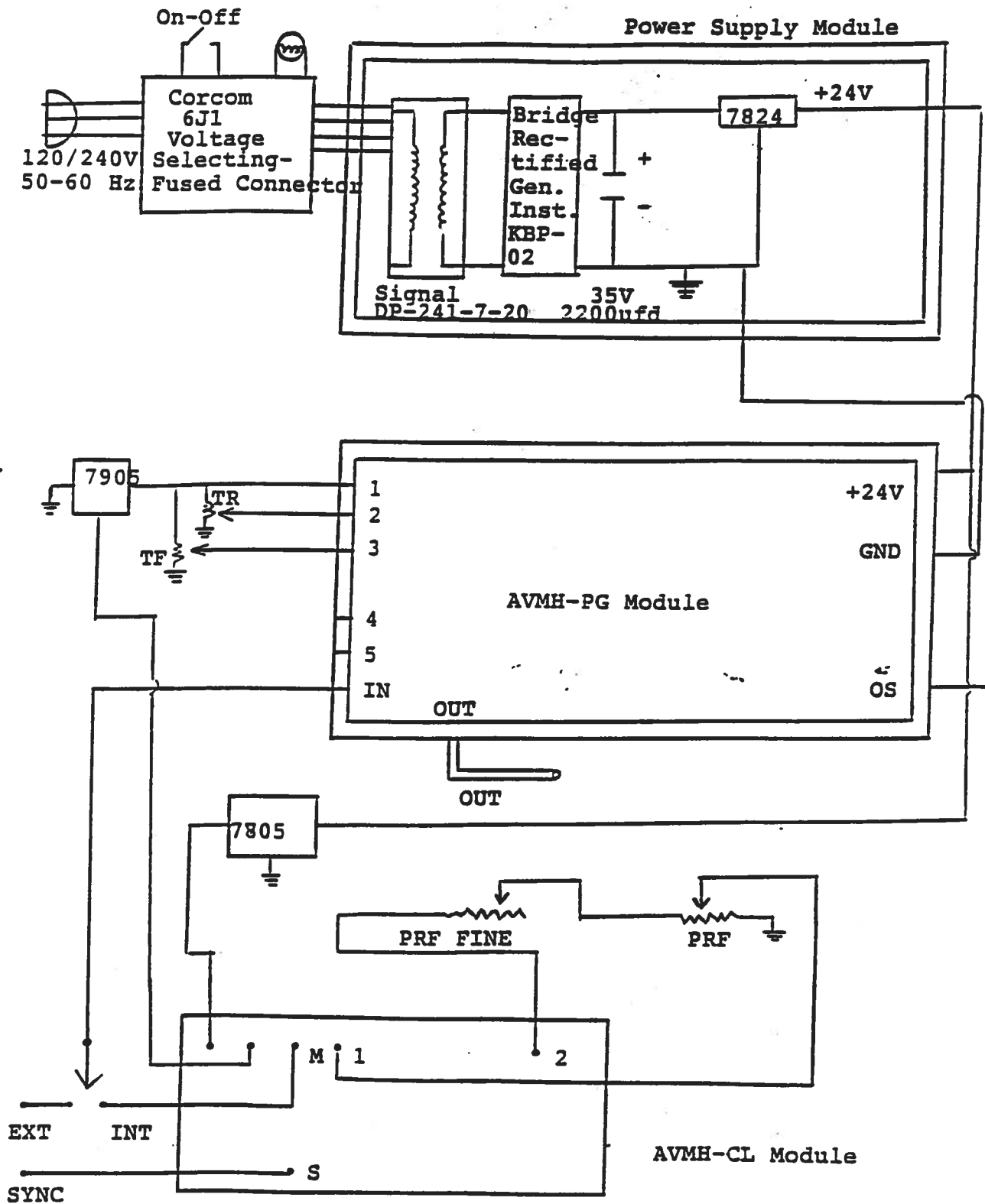

SYSTEM DESCRIPTION AND REPAIR PROCEDURE

The AVMH-C consists of a pulse generator module (AVMH-PG), a clock module (AVMH-CL) and a power supply board which supplies +24 Volts (600 mA max) to the pulse generator module. In the event that the unit malfunctions, remove the instrument cover by removing the four Phillips screws on the back panel of the unit. The top cover may then be slid off. Measure the voltage at the +24 V pin of the PG module. If this voltage is substantially less than +24 Volts, unsolder the line connecting the power supply and PG modules and connect 50 Ohm 10 W load to the PS output. The voltage across this load should be about +24 V DC. If this voltage is substantially less than 24 Volts the PS module is defective and should be repaired or replaced. If the voltage across the resistor is near 24 Volts, then the PG module should be replaced or repaired. The sealed PG module must be returned to Avtech for repair (or replacement). The clock module provides a 20 ns TTL level trigger pulse at pin M to trigger the PG module and a 20 ns 0.5 V sync pulse at pin S to trigger the sampling scope display device. The output at pin S precedes the output at pin M by 0 to 100 ns depending on the DELAY control setting. With the INT-EXT switch in the EXT position, the clock module is disconnected from the PG module. The clock module is functioning properly if:

- a) 10 ns, or wider, outputs are observed at pins M and S.
- b) The PRF of the outputs can be varied over the range of 10 kHz to 25 MHz using the PRF and PRF RANGE controls.
- c) The relative delay between the pin M and S outputs can be varied by at least 100 ns by the DELAY control.

The sealed clock module must be returned to Avtech for repair or replacement if the above conditions are not observed.

POWER SUPPLY AND FUSE REPLACEMENT

This instrument has three fuses (plus one spare). One, which protects the AC input, is located in the rear-panel power entry module, as described in the "Rear Panel Controls" section of this manual. If the power appears to have failed, check the AC fuse first.

The other two fuses (plus one spare) are located on the internal DC power supply, as shown below:

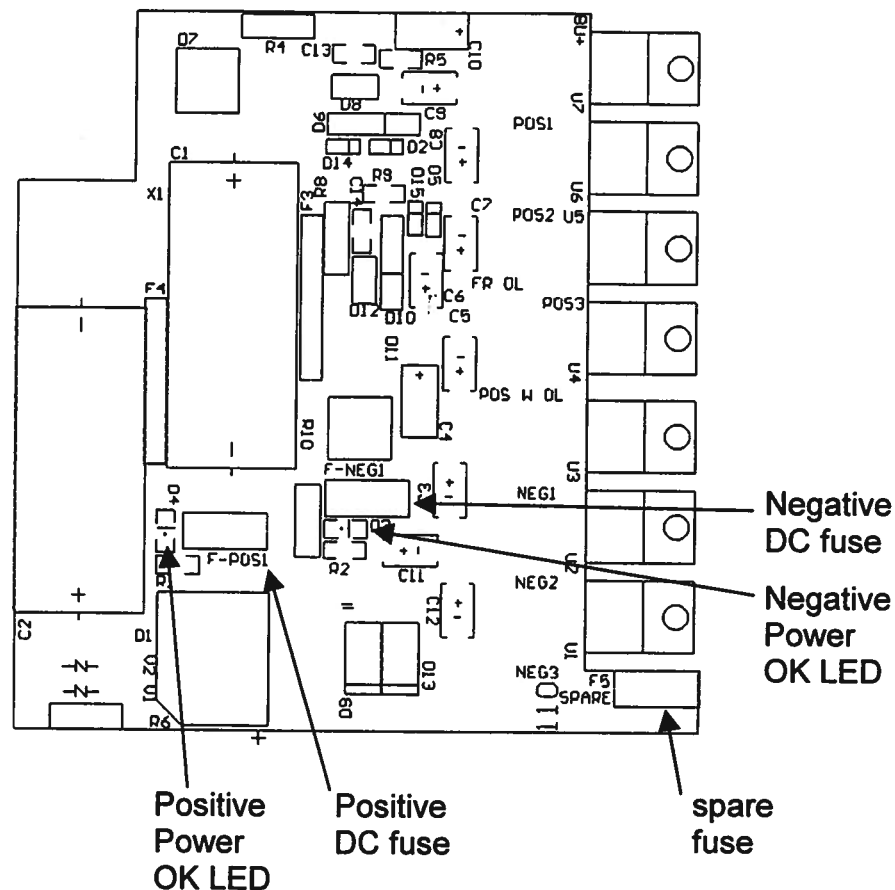

The positive fuse and the spare fuse on this circuit board are 1A slow-blow fuses, Littlefuse part number R452001. (This fuse can be ordered from Digikey, www.digikey.com. The Digikey part number is F1343CT-ND). The negative fuse is a 0.5A slow-blow fuse (Littlefuse R452.500, Digikey part number F1341CT-ND).

If you suspect that the DC fuses are blown, follow this procedure:

1. Remove the top cover, by removing the four Phillips screws on the top cover and then sliding the cover back and off.
2. Locate the two "Power OK" LEDs on the power supply circuit board, as illustrated above.

3. Turn on the instrument.
4. Observe the "Power OK" LEDs. If the fuses are not blown, the two LEDs will be lit (bright red). If one of the LEDs is not lit, the fuse next to it has blown.
5. Turn off the instrument.
6. If a fuse is blown, use needle-nose pliers to remove the blown fuse from its surface-mount holder.
7. Replace the fuse.