

# AVTECH ELECTROSYSTEMS LTD.

NANOSECOND WAVEFORM ELECTRONICS  
ENGINEERING . MANUFACTURING

□ P.O. BOX 265  
OGDENSBURG  
NEW YORK  
13669  
(315) 472-5270

BOX 5120 STN. "F"  
OTTAWA, ONTARIO  
CANADA K2C 3H4  
Y (613) 226-5772  
TELEX 053-4591

## INSTRUCTIONS

MODEL AVMH-PS PULSE GENERATOR

S.N.:

## WARRANTY

Avtech Electrosystems Ltd. warrants products of its manufacture to be free from defects in material and workmanship under conditions of normal use. If, within one year after delivery to the original owner, and after prepaid return by the original owner, this Avtech product is found to be defective, Avtech shall at its option repair or replace said defective item. This warranty does not apply to units which have been disassembled, modified or subjected to conditions exceeding the applicable specifications or ratings. This warranty is the extent of the obligation or liability assumed by Avtech with respect to this product and no other warranty or guarantee is either expressed or implied.

MODEL AVM-PS PULSE GENERATOR TEST ARRANGEMENT

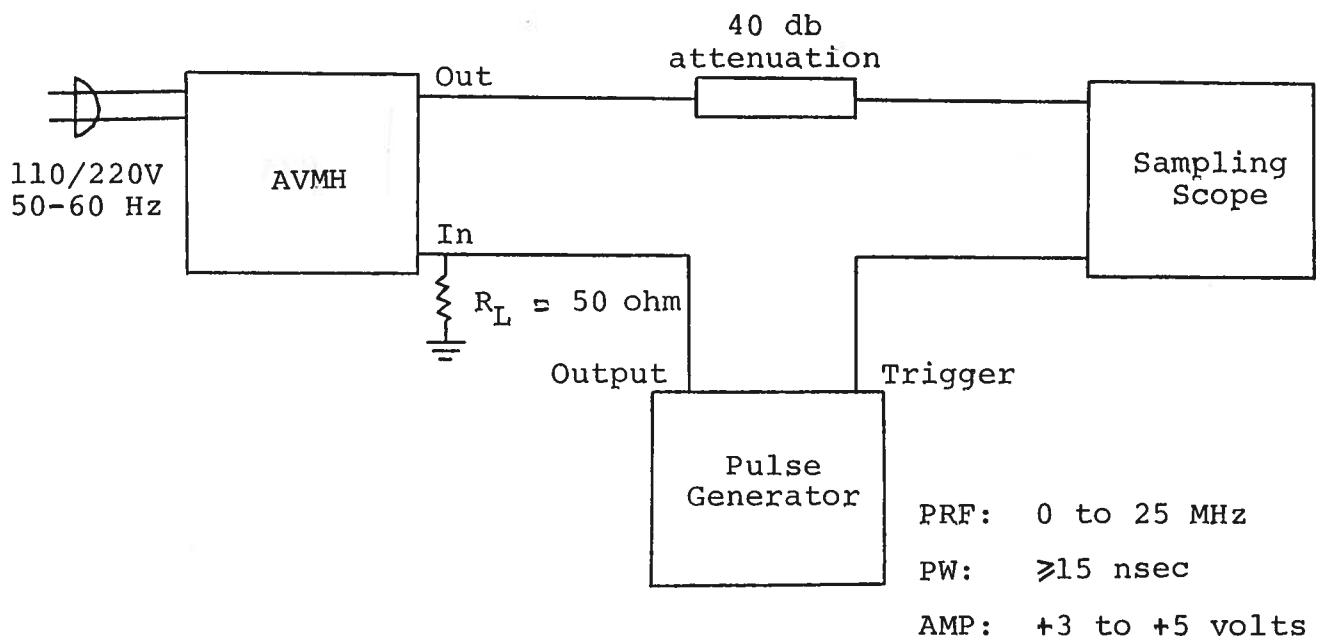

Notes:

- 1) The bandwidth capability of components and instruments used to display the pulse generator output signal (attenuators, cables, connectors, etc.) should exceed ten gigahertz.
- 2) The use of 40 db attenuator will insure a peak input signal to the sampling scope of less than one volt.
- 3) In general, the source pulse generator trigger delay control should be set in the 0.1 to 1.0 usec range.
- 4) When testing using a general purpose 50 ohm laboratory pulse generator as the input trigger signal source, the input signal should be applied via a 50 ohm feed-through load or alternatively, the input to the AVM unit should be shunted with a 50 ohm resistor. This will prevent reflection (and degradation of the input pulse waveform) caused by the high impedance at the IN port. However, when triggering from a TTL source, no 50 ohm feed-through load or resistor is necessary but lead length should be as short as possible. High-speed TTL Schottky logic is recommended for the driving circuitry.
- 5) The input trigger pulse width should be greater than 15 nsec and less than one half of the pulse repetition frequency period. The unit triggers on the leading edge of the input trigger signal.
- 6) The output pulse width is controlled by means of the one turn  $T_R$  and  $T_F$  controls. The  $T_R$  control controls the position of the leading edge while the  $T_F$  control determines the position of the falling edge. Clockwise rotation of these controls causes the pulse edge to move to the right. It is necessary to sequentially adjust the  $T_R$ ,  $T_F$  and AMP controls to obtain the desired output pulse width and amplitude.
- 7) The output pulse amplitude is controlled by means of the front panel one turn AMP control. The pulse width may change by several nanoseconds as the output amplitude is reduced from maximum to minimum. Therefore it is convenient to first set the desired amplitude and then set the desired pulse width as described above.
- 8) Some properties of the output pulse may change as a function of the amplitude pot setting. For some demanding applications, it may be desirable to use a combination of external attenuators and the amplitude pot to achieve the desired output amplitude.
- 9) WARNING: Model AVMH-PS may fail if triggered at a PRF greater than 25.0 MHz.

- 10) The Model AVMH-PS pulse generator can withstand an infinite VSWR on the output port.
- 11) To DC offset the output pulse connect a DC power supply set to the required DC offset value to the terminals marked D.S. The maximum attainable DC offset voltage is 50 volts.
- 12) The unit can be converted from 110 to 220V 50-60 Hz operation by adjusting the voltage selector card in the rear panel fused voltage selector cable connector assembly.
- 13) To invert the output of the AVMH unit, connect the AVX-2-T unit to the OUT port. An inverted pulse is then obtained at the OUT port of the AVX-2-T unit. To offset the inverted pulse, apply the required DC level to the DC terminal of the AVX-2-T unit.
- 14) The monitor output provides an attenuated ( $\times 10$ ) coincident replica (to 50 ohms) of the main output (-M option).

## SYSTEM DESCRIPTION AND REPAIR PROCEDURE

The AVMH-2-PS consists of a pulse generator module (AVMH-2-PG) and a power supply board which supplies +24 volts (600 mA max) to the pulse generator module. In the event that the AVMH-PS unit malfunctions, remove the instrument cover by removing the four Phillips screws on the back of the unit. The top lid may then be slid off. Measure the voltage at the +24V pin of the PG module. If this voltage is substantially less than +24 volts, unsolder the line connecting the power supply and PG modules and connect 50 ohm 10 W load to the PS output. The voltage across this load should be about +24 V DC. If this voltage is substantially less than 24 volts the PS module is defective and should be repaired or replaced. If the voltage across the resistor is near 24 volts, then the PG module should be replaced or repaired. The sealed PG module must be returned to Avtech for repair (or replacement).

SYSTEM BLOCK DIAGRAM AND REPAIR PROCEDURE

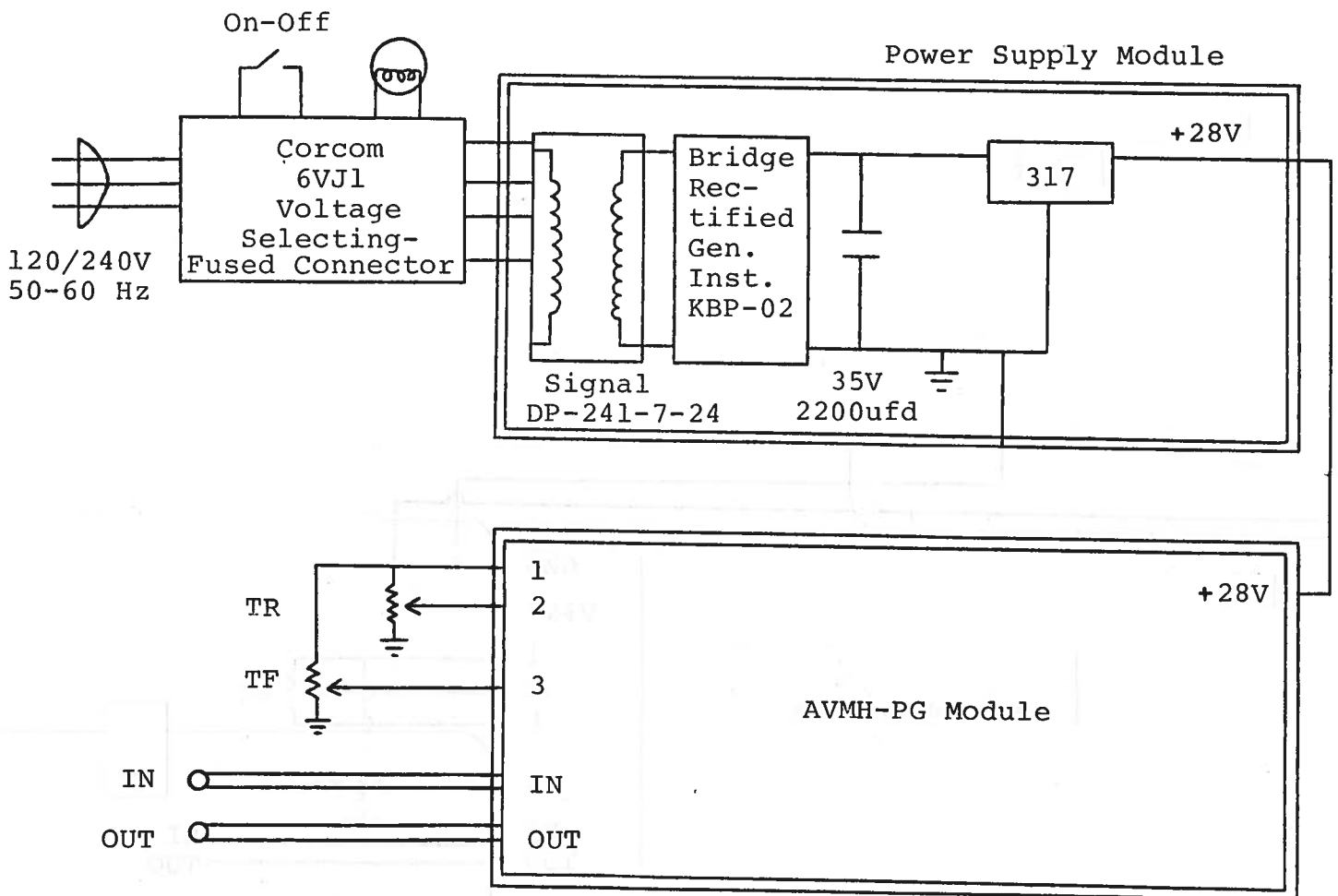

Schnoff 07.09.87

-PN

-OS

-M