



**AVTECH ELECTROSYSTEMS LTD.**

NANOSECOND WAVEFORM ELECTRONICS  
SINCE 1975

P.O. BOX 265  
OGDENSBURG, NY  
U.S.A. 13669-0265  
TEL: (315) 472-5270  
FAX: (613) 226-2802

TEL: 1-800-265-6681  
FAX: 1-800-561-1970  
U.S.A. & CANADA

BOX 5120 STN. F  
OTTAWA, ONTARIO  
CANADA K2C 3H4  
TEL: (613) 226-5772  
FAX: (613) 226-2802

**INSTRUCTIONS**

**MODEL AVMH-3-C PULSE GENERATOR**

**S.N.:**

## WARRANTY

Avtech Electrosystems Ltd. warrants products of its manufacture to be free from defects in material and workmanship under conditions of normal use. If, within one year after delivery to the original owner, and after prepaid return by the original owner, this Avtech product is found to be defective, Avtech shall at its option repair or replace said defective item. This warranty does not apply to units which have been disassembled, modified or subjected to conditions exceeding the applicable specifications or ratings. This warranty is the extent of the obligation or liability assumed by Avtech with respect to this product and no other warranty or guarantee is either expressed or implied.

Fig. 1

PULSE GENERATOR TEST ARRANGEMENT

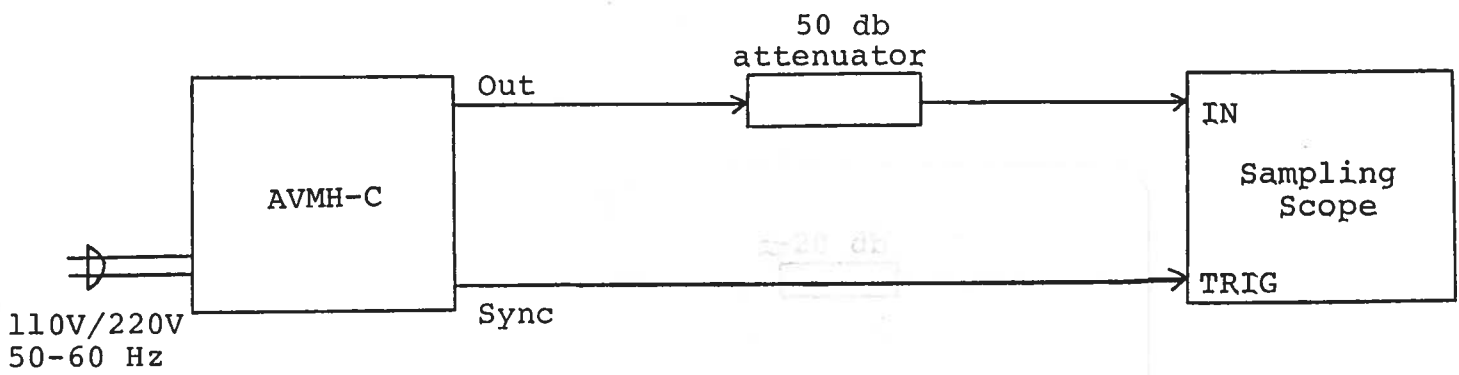

Notes:

- 1) The bandwidth capability of components and instruments used to display the pulse generator output signal (attenuators, cables, connectors, etc.) should exceed ten gigahertz.
- 2) The use of 50 db attenuator at the sampling scope vertical input channel will insure a peak input signal to the sampling scope of less than one volt.
- 3) The sync output channel provides a 0.2 volt 10 ns pulse.
- 4) To obtain a stable output display the PRF and PRF FINE controls on the front panel should be set mid-range while the PRF range switch may be in either range. The front panel TRIG toggle switch should be in the INT position. The front panel DELAY control and the scope triggering controls are then adjusted to obtain a stable output. It is recommended that the DELAY control first be set max counter clockwise and then turned clockwise until a stable display is obtained. The scope may then be used to set the desired PRF by rotating the PRF and PRF FINE controls and by means of the PRF range switch. The stability of the display on some sampling scopes is very sensitive to the trigger delay setting, particularly at high PRF (eg. 10 to 25 MHz). If necessary, consult your sample scope instructions manual for the proper triggering method.
- 5) The output pulse width is controlled by means of the one turn  $T_R$  and  $T_F$  controls. The  $T_R$  control controls the position of the leading edge while the  $T_F$  control determines the position of the falling edge. Clockwise rotation of these controls causes the pulse edge to move to the right. It is necessary to sequentially adjust the  $T_R$ ,  $T_F$  and AMP controls to obtain the desired output pulse width and amplitude.
- 6) The output pulse amplitude is controlled by means of the front panel one turn AMP control. The pulse width may change by several nanoseconds as the output amplitude is reduced from maximum to minimum. Therefore it is convenient to first set the desired amplitude and then set the desired pulse width as described above.
- 7) To DC offset the output pulse connect a DC power supply set to required DC offset value to the back panel terminals marked O.S. The maximum attainable DC offset voltage is  $\pm 50$  volts (for units without the OT or EO option only).

- 8) An external clock may be used to control the output PRF of the AVM unit by setting the front panel TRIG toggle switch in the EXT position and applying a 15 ns (or wider) TTL level pulse to the TRIG BNC connector input. The AVM unit triggers on the rising edge of the input trigger pulse. For operation in this mode, the scope time base must also be triggered by the external clock rather than from the SYNC output.
- 9) **WARNING:** Model AVMH-C may fail if triggered at a PRF greater than 25.0 MHz.
- 10) The Model AVMH-C pulse generator can withstand an infinite VSWR on the output port.
- 11) To invert the output of the AVMH unit, connect the AVX-2-T unit to the OUT port. An inverted pulse is then obtained at the OUT port of the AVX-2-T unit. To offset the inverted pulse, apply the required DC level to the DC terminal of the AVX-2-T unit. (PN option).
- 12) The AVMH-C unit can be converted from 110 to 220V 50-60 Hz operation by adjusting the voltage selector card in the rear panel fused voltage selector-cable connector assembly.
- 13) Units with a serial number above 4600 may also have a rear panel one turn TRB adjustment pot. This pot also controls the rising edge waveform. For PRF below about 10 MHz, the pot should normally be in mid-range but for PRF above 10 MHz the pot should normally be fully counter clockwise.

Fig. 2

FRONT PANEL CONTROLS

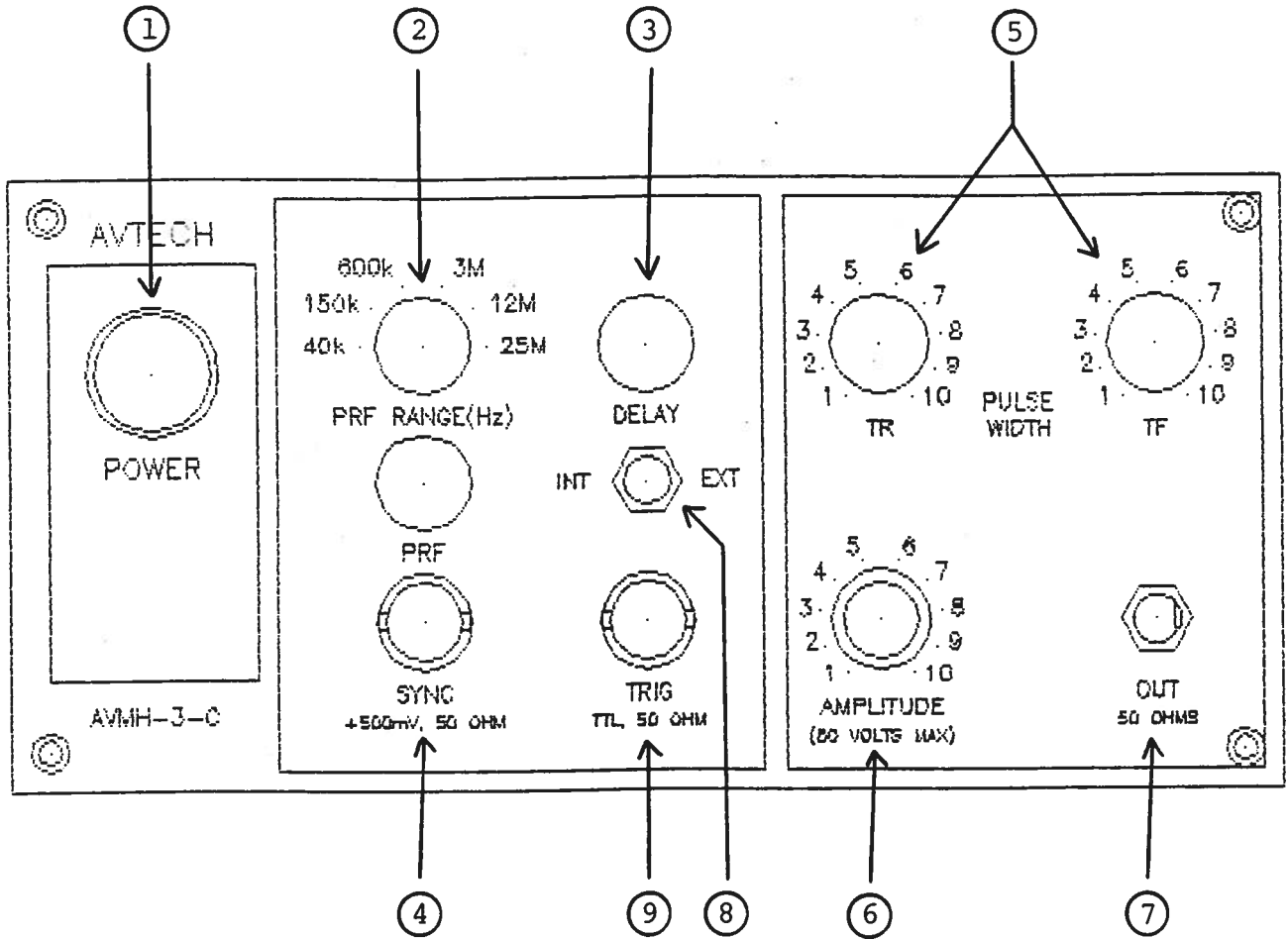

## FRONT PANEL CONTROLS

- (1) ON-OFF Switch. Applies basic prime power to all stages.
- (2) PRF Control. PRF RANGE and PRF controls determine output PRF as follows:

	PRF MIN	PRF MAX
Range 1	10 kHz	50 kHz
Range 2	50 kHz	250 kHz
Range 3	185 kHz	650 kHz
Range 4	650 kHz	3.3 MHz
Range 5	3.3 MHz	13.3 MHz
Range 6	5.0 MHz	25 MHz

- (3) DELAY Control. Controls the relative delay between the reference output pulse provided at the SYNC output (4) and the main output (7). This delay is variable over the range of 0 to at least 100 ns.
- (4) SYNC Output. This output precedes the main output (7) and is used to trigger the sampling scope time base. The output is a 200 mV 10 nsec (approx) pulse capable of driving a fifty ohm load.
- (5) PW Control. Two one turn controls which varies the output pulse width.  $T_R$  determines the position of the rising edge while  $T_F$  determines the position of the falling edge.
- (6) AMP Control. A one turn control which varies the output pulse amplitude from 0 to max output to a fifty ohm load.
- (7) OUT Connector. SMA connector provides output to a fifty ohm load.
- (8) EXT-INT Control. With this toggle switch in the INT position, the PRF of the AVM unit is controlled via an internal clock which in turn is controlled by the PRF controls. With the toggle switch in the EXT position, the AVM unit requires a 15 nsec (or wider) TTL level pulse applied at the TRIG input in order to trigger the output stages. In addition, in this mode, the scope time base must be triggered by the external trigger source.
- (9) TRIG Input. The external trigger signal is applied at this input when the EXT-INT toggle switch is in the EXT position.

Fig. 3

BACK PANEL CONTROLS

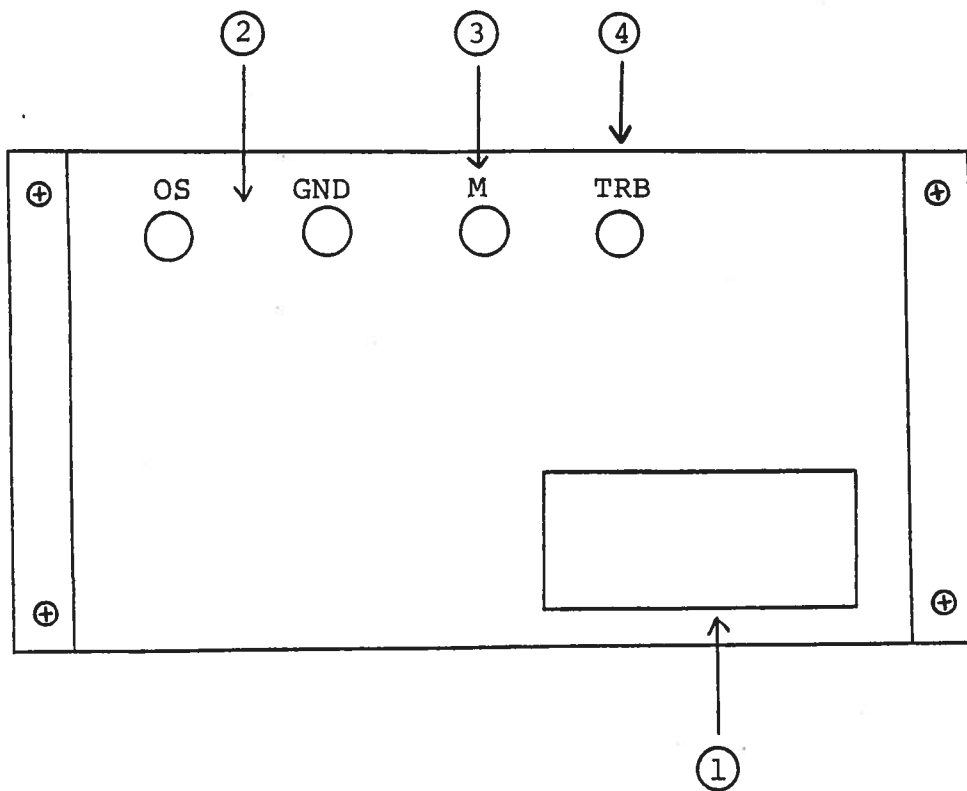



- (1) FUSED CONNECTOR, VOLTAGE SELECTOR. The detachable power cord is connected at this point. In addition, the removable cord is adjusted to select the desired input operating voltage. The unit also contains the main power fuse (0.25 A SB).
- (2) DC OFFSET Input. To DC offset the output pulse, connect a DC power supply set to the desired offset value to these terminals. The maximum allowable DC offset voltage is  $\pm 50$  volts ( $\pm 100$  mA max).
- (3) MONITOR Output. Provides an attenuated (x10) coincident replica (to 50 ohm) of the main output. (option).
- (4) TRB. Units with a serial number above 4600 may also have a rear panel one turn TRB adjustment pot. This pot also controls the rising edge waveform. For PRF below about 10 MHz, the pot should normally be in mid-range but for PRF above 10 MHz the pot should normally be fully counter clockwise.

Fig. 4

SYSTEM BLOCK DIAGRAM

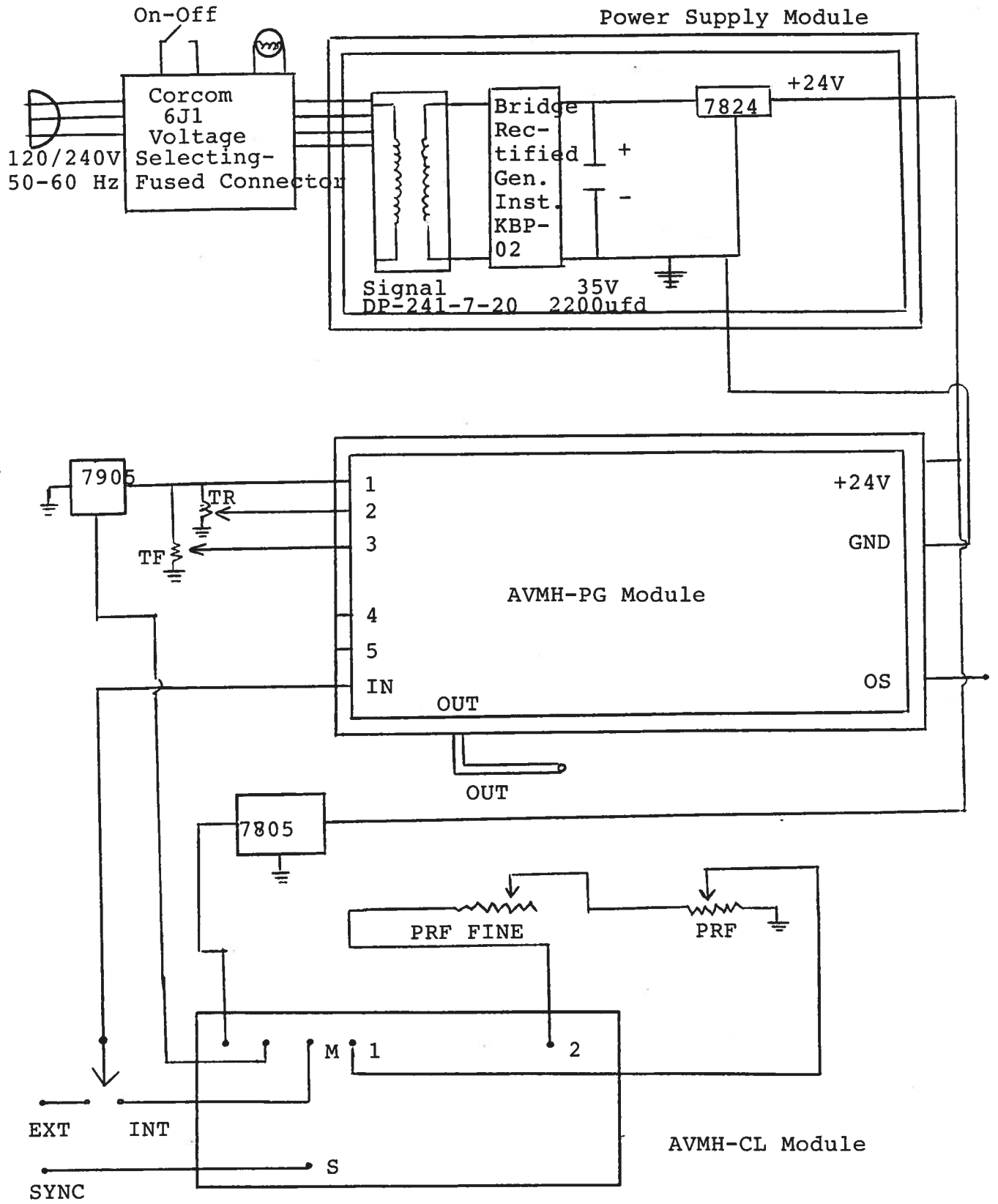

## SYSTEM DESCRIPTION AND REPAIR PROCEDURE

The AVMH-C consists of a pulse generator module (AVMH-PG), a clock module (AVMH-CL) and a power supply board which supplies +24 volts (600 mA max) to the pulse generator module. In the event that the unit malfunctions, remove the instrument cover by removing the four Phillips screws on the back panel of the unit. The top cover may then be slid off. Measure the voltage at the +24 V pin of the PG module. If this voltage is substantially less than +24 volts, unsolder the line connecting the power supply and PG modules and connect 50 ohm 10 W load to the PS output. The voltage across this load should be about +24 V DC. If this voltage is substantially less than 24 volts the PS module is defective and should be repaired or replaced. If the voltage across the resistor is near 24 volts, then the PG module should be replaced or repaired. The sealed PG module must be returned to Avtech for repair (or replacement). The clock module provides a 20 nsec TTL level trigger pulse at pin M to trigger the PG module and a 20 nsec 0.5 V sync pulse at pin S to trigger the sampling scope display device. The output at pin S precedes the output at pin M by 0 to 100 nsec depending on the DELAY control setting. With the INT-EXT switch in the EXT position, the clock module is disconnected from the PG module. The clock module is functioning properly if:

- a) 10 ns, or wider, outputs are observed at pins M and S.
- b) The PRF of the outputs can be varied over the range of 10 kHz to 25 MHz using the PRF and PRF RANGE controls.
- c) The relative delay between the pin M and S outputs can be varied by at least 100 ns by the DELAY control.

The sealed clock module must be returned to Avtech for repair or replacement if the above conditions are not observed.

-05

-M

SYSTEM DESCRIPTION AND REPAIR PROCEDURE

The AVMM-C consists of a pulse generator module (AVMM-1G), a clock module (AVMM-CL) and a power supply board which supplies +5V volts (600 mA max) to the pulse generator module. In the event that the unit malfunctions, remove the instrument cover by removing the four Phillips screws on the back panel of the unit. The top cover may then be slid off. Measure the voltage at the 1.1 V pin of the PG module. If this voltage is substantially less than +54 volts, unplug the line connecting the power supply and PG module and connect 50 ohm 10 W load to the P2 output. The voltage across this load should be about +24 V DC. If this voltage is substantially less than 24 volts the PG module is defective and should be repaired or replaced. If the voltage across the resistor is near 24 volts, then the PG module should be repaired or replaced. The sealed PG module must be returned to Avtech for repair (or replacement). The clock module provides a 50 nsec TTL level trigger pulse at pin M to trigger the PG module and a 50 nsec 0.5 V sync pulse at pin S to trigger the sampling scope display device. The output at pin S precedes the output at pin M by 0 to 100 nsec depending on the DELAY control setting. With the INT-EXT switch in the EXT position, the clock module is disconnected from the PG module. The clock module is functioning properly if:

- a) 10 ns, or wider, outputs are observed at pins M and S.
- b) The PRR of the outputs can be varied over the range of 10 kHz to 92 MHz using the PRR and PRR RANGE controls.
- c) The relative delay between the pin M and S outputs can be varied by at least 100 ns by the DELAY control.

The sealed clock module must be returned to Avtech for repair or replacement if the above conditions are not observed.