

AVTECH ELECTROSYSTEMS LTD.

NANOSECOND WAVEFORM ELECTRONICS
ENGINEERING - MANUFACTURING

□ P.O. BOX 265
OGDENSBURG
NEW YORK
13669
(315) 472-5270

✕
□ BOX 5120, STN. "F"
OTTAWA, ONTARIO
CANADA K2C 3H4
TEL: (613) 226-5772
FAX: (613) 226-2802

INSTRUCTIONS

MODEL AVMP-EW PULSE GENERATOR

S.N. :

WARRANTY

Avtech Electrosystems Ltd. warrants products of its manufacture to be free from defects in material and workmanship under conditions of normal use. If, within one year after delivery to the original owner, and after prepaid return by the original owner, this Avtech product is found to be defective, Avtech shall at its option repair or replace said defective item. This warranty does not apply to units which have been disassembled, modified or subjected to conditions exceeding the applicable specifications or ratings. This warranty is the extent of the obligation or liability assumed by Avtech with respect to this product and no other warranty or guarantee is either expressed or implied.

MODEL AVMP PULSE GENERATOR TEST ARRANGEMENT

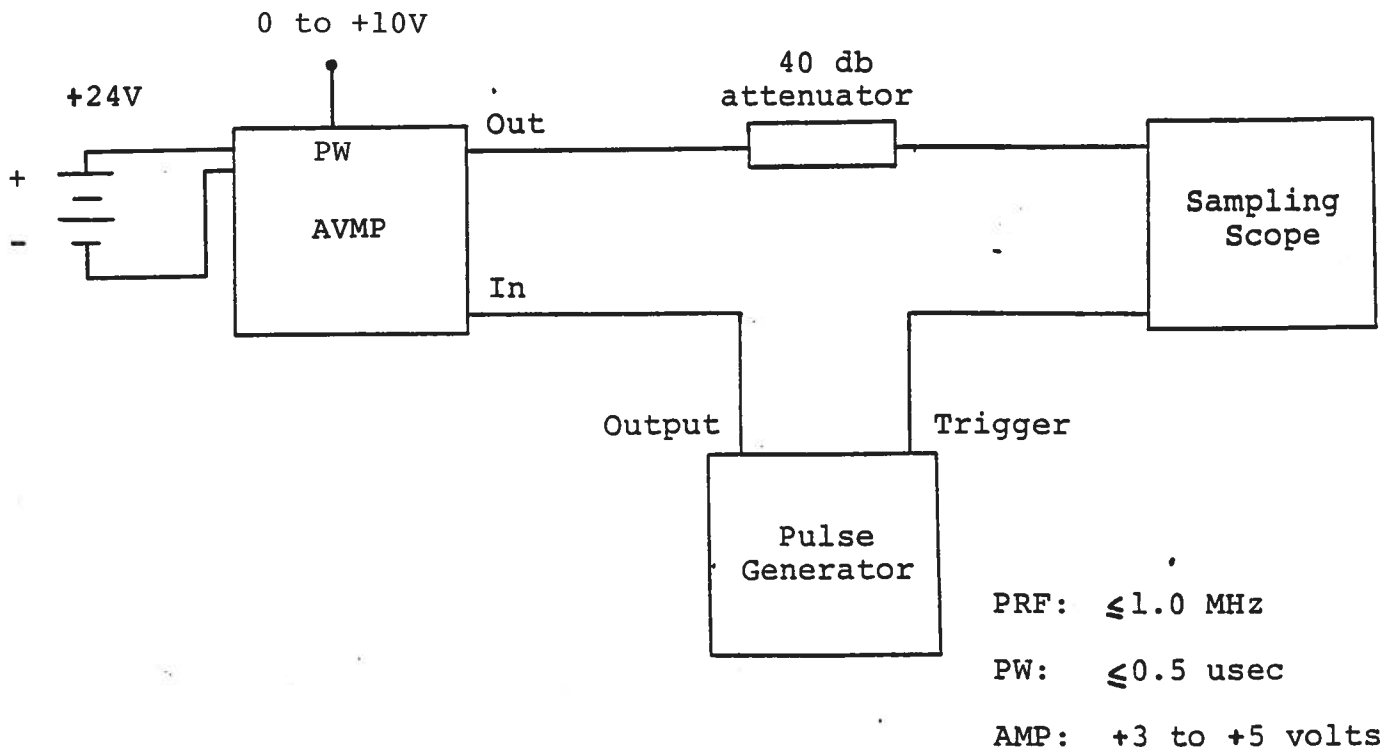

Notes:

- 1) The bandwidth capability of components and instruments used to display the pulse generator output signal (attenuators, cables, connectors, etc.) should exceed ten gigahertz.
- 2) The use of 40 db attenuator will insure a peak input signal to the sampling scope of less than one volt.
- 3) In general, the source pulse generator trigger delay control should be set in the 0.1 to 1.0 usec range. Other settings should be as shown in the above diagram.
- 4) The Model AVMP pulse generator can withstand an infinite VSWR on the output port.
- 5) WARNING: Model AVMP may fail if triggered at a PRF greater than 1.0 MHz.
- 6) The output pulse width is controlled by means of 0 to +10 volts applied to the PW solder terminal ($R_{IN} > 10K$).
- 7) The output pulse amplitude is controlled by means of the one turn potentiometer (AMP). The pulse width may change by several nanoseconds as the output amplitude is reduced from maximum to minimum. Therefore it is convenient to first set the desired amplitude and then set the desired pulse width.
- 8) Some properties of the output pulse may change as a function of the amplitude pot setting. For some demanding applications, it may be desirable to use a combination of external attenuators and the amplitude pot to achieve the desired output amplitude.
- 9) To DC offset the output pulse at the AVMP output, connect a DC power supply set to the required DC offset value to the rear panel OS terminals.
- 10) The monitor output (-M) provides a 20 db attenuated coincident replica of the main output. (option).

11.18.91

- OS

- M