



AVTECH ELECTROSYSTEMS LTD.
NANOSECOND WAVEFORM ELECTRONICS

P. O. BOX 265
OGDENSBURG, NY
U.S.A. 13669-0265
TEL: (315) 472-5270
FAX: (613) 226-2802

BOX 5120 STN. F
OTTAWA, ONTARIO
CANADA K2C 3H4
TEL: (613) 226-5772
FAX: (613) 226-2802

INSTRUCTIONS

MODEL AVMR-1-F-C-STA PULSE GENERATOR

S.N. :

WARRANTY

Avtech Electrosystems Ltd. warrants products of its manufacture to be free from defects in material and workmanship under conditions of normal use. If, within one year after delivery to the original owner, and after prepaid return by the original owner, this Avtech product is found to be defective, Avtech shall at its option repair or replace said defective item. This warranty does not apply to units which have been disassembled, modified or subjected to conditions exceeding the applicable specifications or ratings. This warranty is the extent of the obligation or liability assumed by Avtech with respect to this product and no other warranty or guarantee is either expressed or implied.

Fig. 1

PULSE GENERATOR TEST ARRANGEMENT

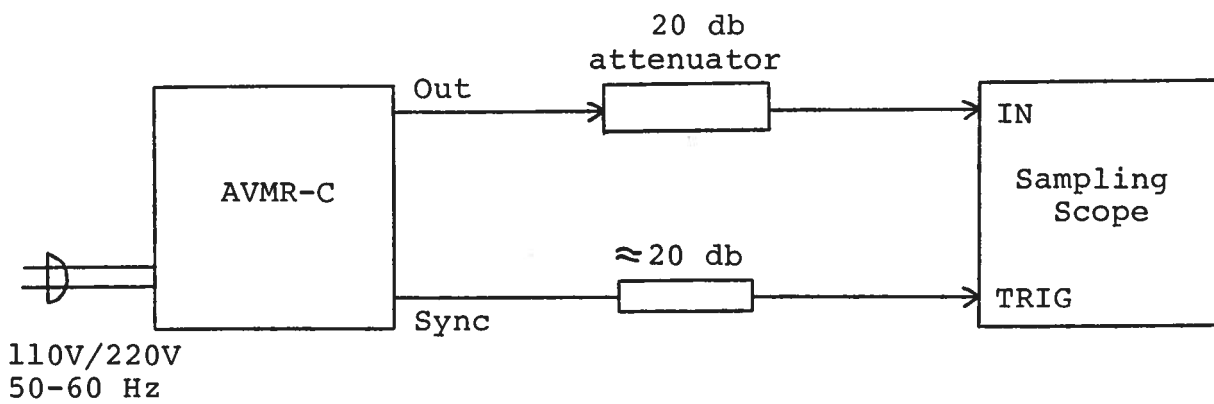

Notes:

- 1) The bandwidth capability of components and instruments used to display the pulse generator output signal (attenuators, cables, connectors, etc.) should exceed one gigahertz.
- 2) The use of 20 db attenuator at the sampling scope vertical input channel will insure a peak input signal to the sampling scope of less than one volt.
- 3) The sync output channel provides a +0.5 V pulse. To avoid overdriving the TRIG input channel of some sampling scopes, a 20 db attenuator should be placed at the input to the sampling scope trigger channel.
- 4) To obtain a stable output display the PRF and PRF FINE controls on the front panel should be set mid-range while the PRF range switch may be in either range. The front panel TRIG toggle switch should be in the INT position. The front panel DELAY control and the scope triggering controls are then adjusted to obtain a stable output. It is recommended that the DELAY control first be set max counter clockwise and then turned clockwise until a stable display is obtained. The scope may then be used to set the desired PRF by rotating the PRF and PRF FINE controls and by means of the PRF range switch.
- 5) The output pulse width is controlled by means of the front panel one turn PW control. The control should initially be set maximum counter clockwise and the pulse width adjusted using an oscilloscope.
- 6) To voltage control the output pulse width, set the rear panel switch in the EXT position and apply 0 to +10V to connector A ($R_{IN} \geq 10K$). (EW option).
- 7) The output pulse amplitude is controlled by means of the front panel one turn AMP control.
- 8) To voltage control the output amplitude, set the rear panel switch in the EXT position and apply 0 to +10V to connector B ($R_{IN} \geq 10K$). (EA option).
- 9) To DC offset the output pulse connect a DC power supply set to required DC offset value to the back panel terminals marked O.S. The maximum attainable DC offset voltage is ± 50 volts. For units with the OT option, the output DC offset level is varied from -5 to +5V (to 50 ohm) by the front panel OFFSET one turn control. The DC offset may be turned off using the rear panel OS ON-OFF toggle switch. For units with the EO option, the output offset may be voltage controlled by setting the rear panel switch in the EXT position and applying 0 to +10 volts to connector A ($R_{IN} \geq 10K$).

- 10) An external clock may be used to control the output PRF of the AVMR unit by setting the front panel TRIG toggle switch in the EXT position and applying a 50 nsec, or under, TTL level pulse to the TRIG BNC connector input. For operation in this mode, the scope time base must also be triggered by the external clock rather than from the SYNC output.
- 11) WARNING: Model AVMR-C may fail if triggered at a PRF greater than 5.0 MHz.

- 12) Dual Polarity Option (for units without the OT or EO options).

To invert the output of the AVMR unit, connect the AVX-3-T unit to the OUT port. An inverted pulse is then obtained at the OUT port of the AVX-3-T unit. To offset the inverted pulse, apply the required DC level to the DC terminal of the AVX-3-T unit.

- 13) Dual Polarity Option (for units with the OT or EO options).

To invert the output of the AVMR unit, connect the AVX-3-T unit to the OUT port. An inverted pulse is then obtained at the OUT port of the AVX-3-T unit. To offset the inverted pulse, connect a lead from the rear panel DS OUT banana plug to the DC terminal of the AVX-3-T unit. The DC offset at the output of the AVX-3-T unit is then controlled by the front panel OFFSET control.

- 14) The rise and fall time are switched from the high to low range by means of the TR and TF two position switches. (TRF option).
- 15) The monitor output (-M) provides a 20 db attenuated coincident replica of the main output. (option).
- 16) The AVMR-C unit can be converted from 110 to 220V 50-60 Hz operation by adjusting the voltage selector card in the rear panel fused voltage selector-cable connector assembly.
- 17) For additional assistance:

Tel: (613) 226-5772
Fax: (613) 226-2802

Fig. 2

FRONT PANEL CONTROLS

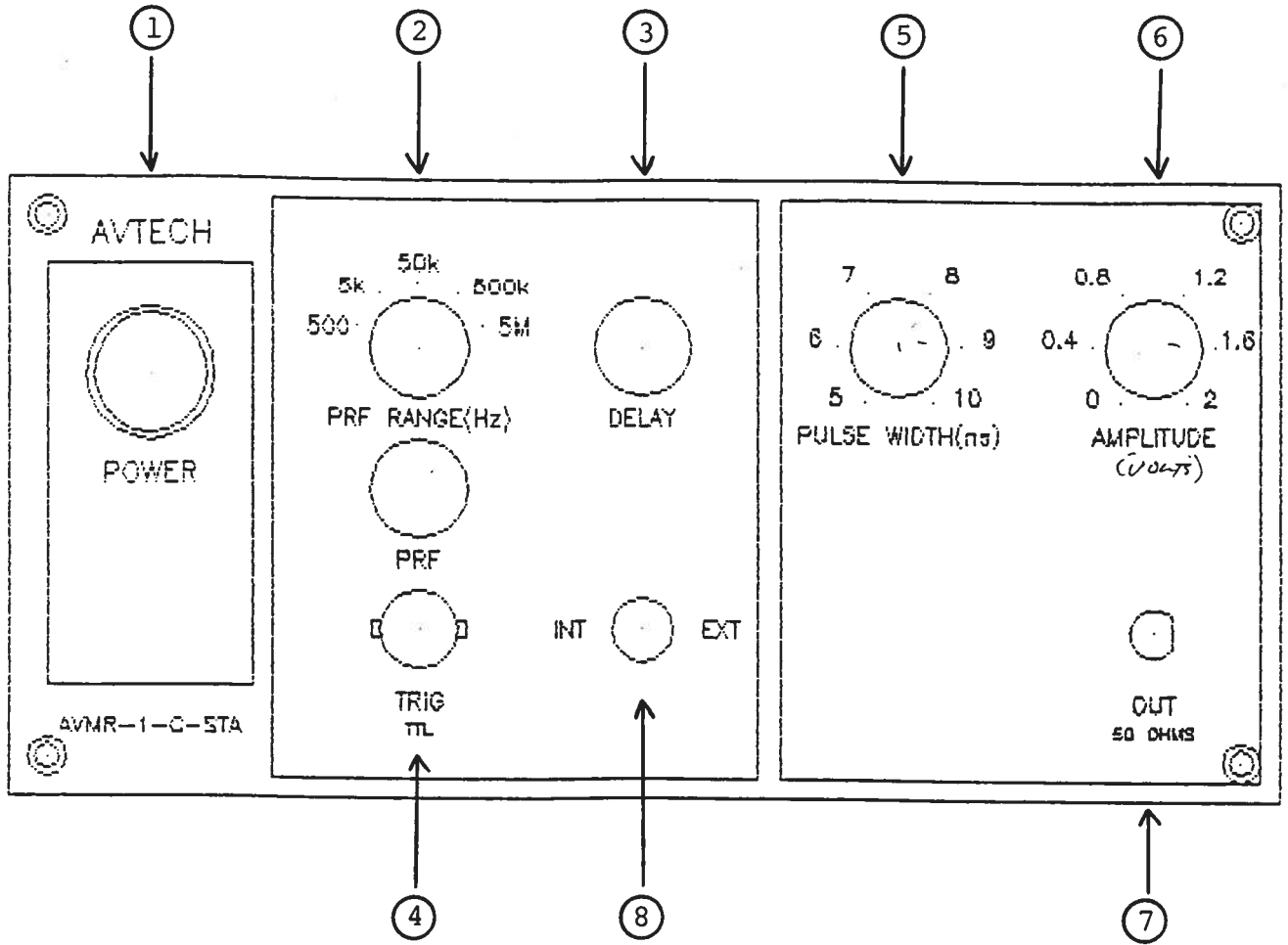

- (1) ON-OFF Switch. Applies basic prime power to all stages.
- (2) PRF Control. PRF RANGE, PRF and PRF FINE controls determine output PRF as follows:

	PRF MIN	PRF MAX
Range 1	50 Hz	500 Hz
Range 2	500 Hz	5 kHz
Range 3	5 kHz	50 kHz
Range 4	50 kHz	500 kHz
Range 5	500 kHz	5 MHz

- (3) DELAY Control. Controls the relative delay between the reference output pulse provided at the TRIG output (4) and the main output (7). This delay is variable over the range of 0 to at least 100 ns.
- (4) TRIG Output. This output precedes the main output (7) and is used to trigger the sampling scope time base. The output is a +0.5V 20 ns (approx) pulse capable of driving a fifty ohm load.
- (5) PW Control. A one turn control which varies the output pulse width.
- (6) AMP Control. A one turn control which varies the output pulse amplitude from 0 to max output to a fifty ohm load.
- (7) OUT Connector. SMA connector provides output to a fifty ohm load.
- (8) EXT-INT Control. With this toggle switch in the INT position, the PRF of the AVMR unit is controlled via an internal clock which in turn is controlled by the PRF and PRF FINE controls. With the toggle switch in the EXT position, the AVMR unit requires a 10 ns (or wider) TTL level pulse applied at the TRIG input in order to trigger the output stages. In addition, in this mode, the scope time base must be triggered by the external trigger source.

Fig. 3

BACK PANEL CONTROLS (Units without TRF, OT or EO options but with PN option)

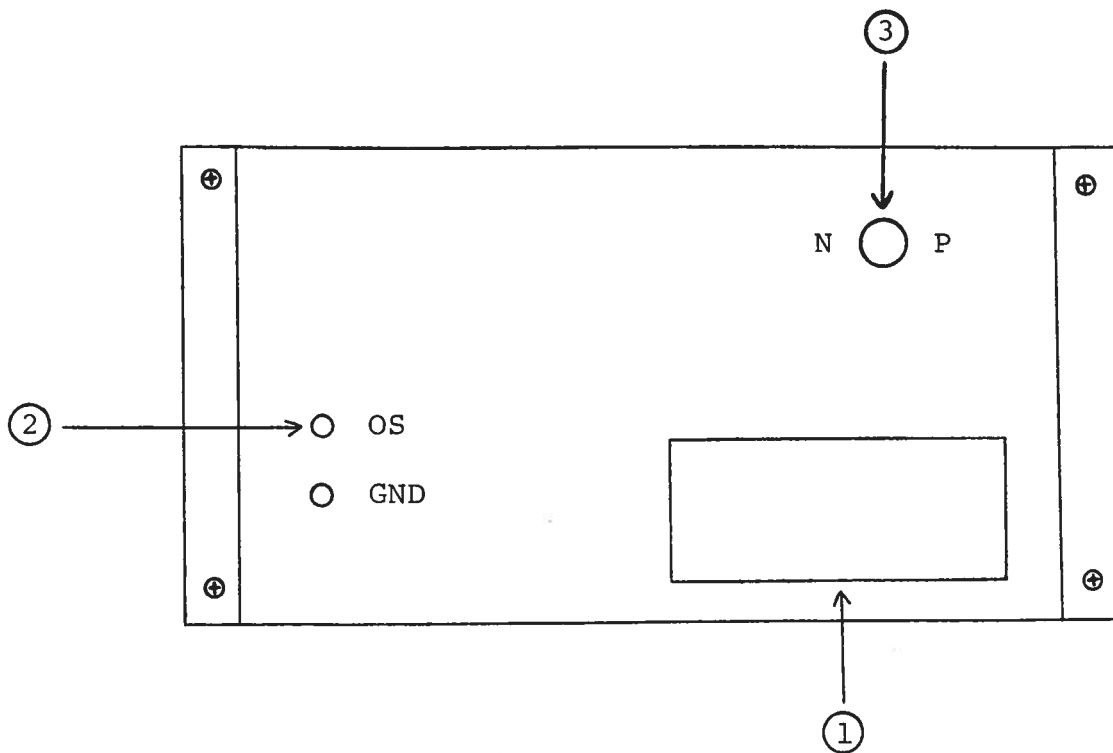

- (1) FUSED CONNECTOR, VOLTAGE SELECTOR. The detachable power cord is connected at this point. In addition, the removable cord is adjusted to select the desired input operating voltage. The unit also contains the main power fuse (0.25 A SB).
- (2) DC OFFSET Input. To DC offset the output pulse, connect a DC power supply set to the desired offset value to these terminals. The maximum allowable DC offset voltage is ± 50 volts (100 mA).
- (3) Output Polarity. Two position switch controls output polarity (non TRF units with PN option only).

Fig. 4

SYSTEM BLOCK DIAGRAM

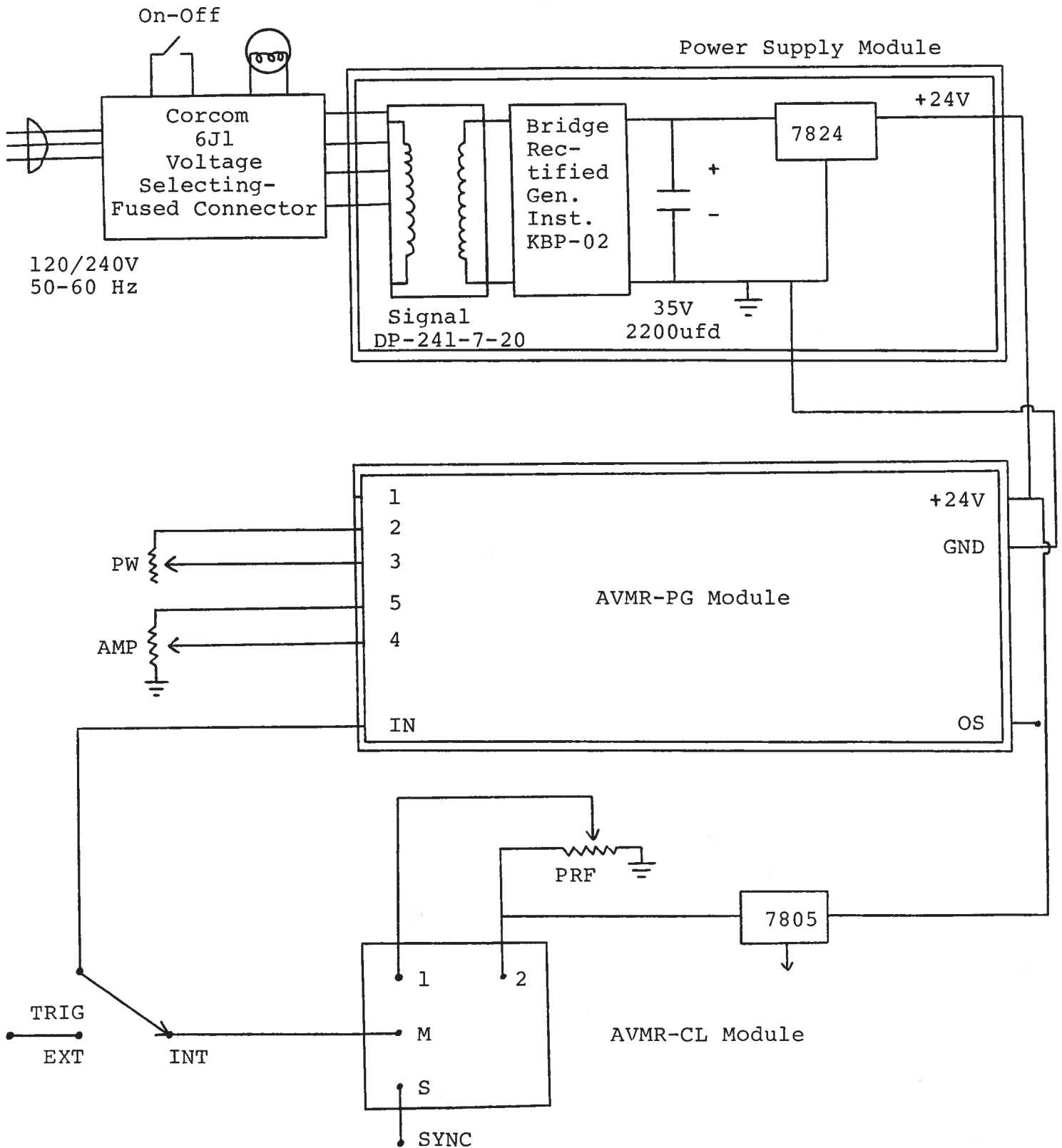

SYSTEM DESCRIPTION AND REPAIR PROCEDURE

The AVMR-C consists of a pulse generator module (AVMR-PG), a clock module (AVMR-CL) and a power supply board which supplies +24 volts (600 mA max) to the pulse generator module. In the event that the unit malfunctions, remove the instrument cover by removing the four Phillips screws on the back panel of the unit. The top cover may then be slid off. Measure the voltage at the +24 V pin of the PG module. If this voltage is substantially less than +24 volts, unsolder the line connecting the power supply and PG modules and connect 50 ohm 10 W load to the PS output. The voltage across this load should be about +24 V DC. If this voltage is substantially less than 24 volts the PS module is defective and should be repaired or replaced. If the voltage across the resistor is near 24 volts, then the PG module should be replaced or repaired. The sealed PG module must be returned to Avtech for repair (or replacement). The clock module provides a 20 nsec TTL level trigger pulse at pin M to trigger the PG module and a 20 nsec 0.5 V sync pulse at pin S to trigger the sampling scope display device. The output at pin S precedes the output at pin M by 0 to 100 nsec depending on the DELAY control setting. With the INT-EXT switch in the EXT position, the clock module is disconnected from the PG module. The clock module is functioning properly if:

- a) 20 nsec outputs are observed at pins M and S.
- b) The PRF of the outputs can be varied over the range of 10 Hz to 25 MHz using the PRF, PRF FINE and PRF RANGE controls.
- c) The relative delay between the pin M and S outputs can be varied by at least 100 nsec by the DELAY control.

The sealed clock module must be returned to Avtech for repair or replacement if the above conditions are not observed.

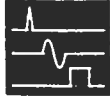
AVTECH**AVTECH ELECTROSYSTEMS LTD.**
NANOSECOND WAVEFORM ELECTRONICS

□ P.O. BOX 265
OGDENSBURG, NY
U.S.A. 13669-0265
TEL: (315) 472-5270
FAX: (613) 226-2802

□
X BOX 5120 STN. F
OTTAWA, ONTARIO
CANADA K2C 3H4
TEL: (613) 226-5772
FAX: (613) 226-2802

March 16, 1993.

Seongcheol Kim
Attn: Mike Stern
Symbol Technology
R&D Dept.
116 Wilbur Place
Bohemia, NY 11716

Tel: 516-563-2400 Ext. 4472
or 4006
Fax: 516-244-4618

Dear Seongcheol:

Following our telephone conversation of March 16, I am pleased to offer the following revised price and delivery quotation:

Model designation: AVMR-1-P-C-STA.
Output amplitude: 0 to +2 Volts to 50 Ohms
(one turn control).
Output pulse width: 5 to 10 ns (one turn control).
Rise, fall time: ≤ 1 ns.
PRF: 0 to 5 MHz.
Other: See standard AVMR-1-C, pages 32 and 33,
Cat. No. 8.
Price: \$2,398.00 US each, FOB destination.
Delivery: 30 days.

Thank you for your interest in our products. Please call me again if you require any additional information.

Yours truly,

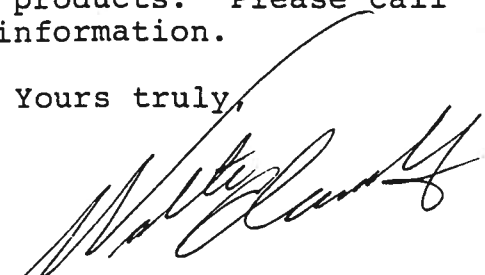

Dr. Walter Chudobiak
Chief Engineer

WC:pr

06.16.93

-EW

-EA

-OS

-PN

-TRF

-M