

**AVTECH ELECTROSYSTEMS LTD.**

**NANOSECOND WAVEFORM ELECTRONICS  
ENGINEERING . MANUFACTURING**

□ P.O. BOX 265  
OGDENSBURG  
NEW YORK  
13669  
(315) 472.5270

BOX 5120 STN. "F"  
OTTAWA, ONTARIO  
CANADA K2C 3H4  
X (613) 226-5772  
TELEX 053.4591

**INSTRUCTIONS**

**MODEL AVMR-2-PW-PS PULSE GENERATOR**

**S.N. :**

## WARRANTY

Avtech Electrosystems Ltd. warrants products of its manufacture to be free from defects in material and workmanship under conditions of normal use. If, within one year after delivery to the original owner, and after prepaid return by the original owner, this Avtech product is found to be defective, Avtech shall at its option repair or replace said defective item. This warranty does not apply to units which have been disassembled, modified or subjected to conditions exceeding the applicable specifications or ratings. This warranty is the extent of the obligation or liability assumed by Avtech with respect to this product and no other warranty or guarantee is either expressed or implied.

MODEL AVMR-2 PULSE GENERATOR TEST ARRANGEMENT

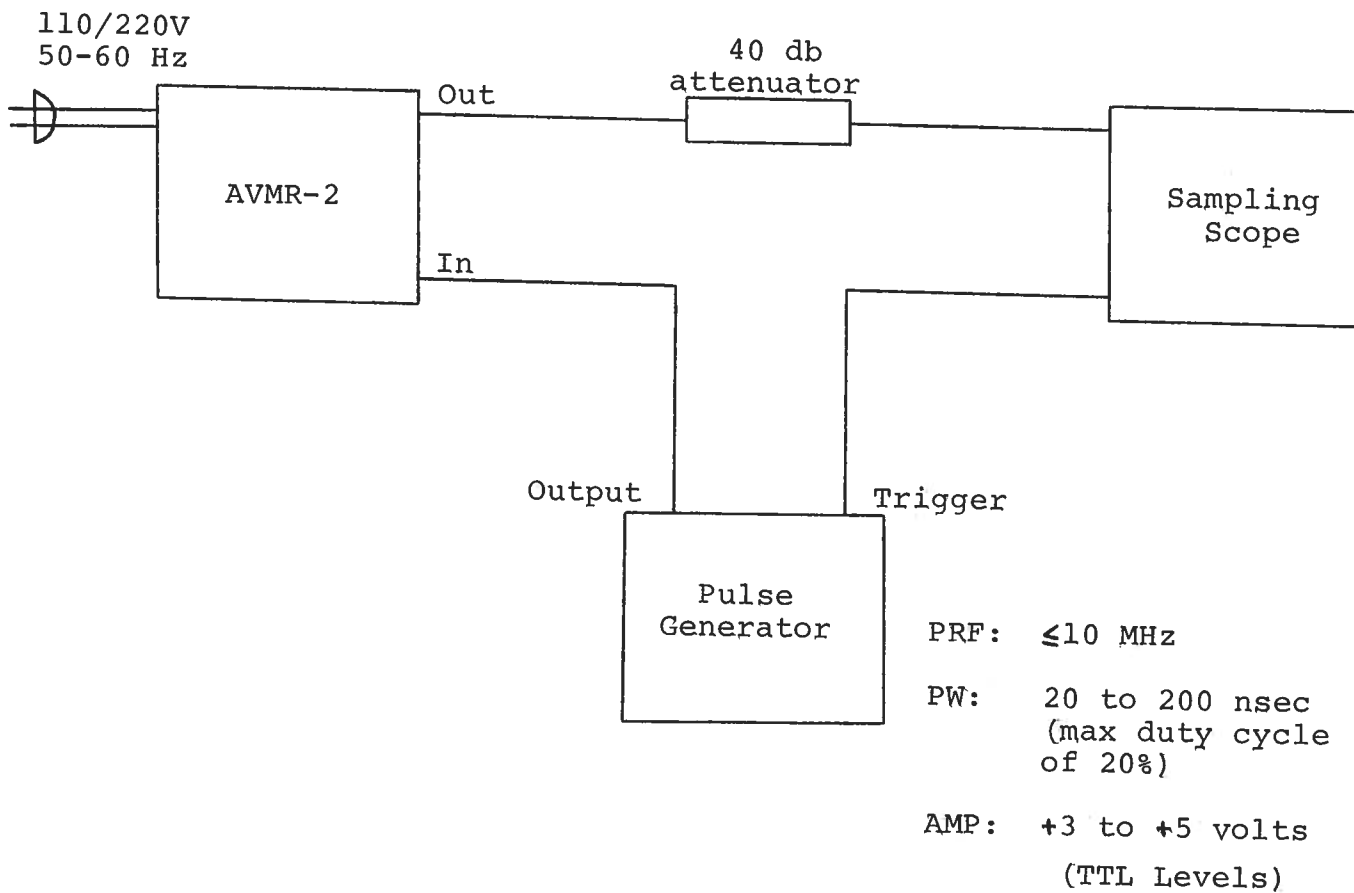

Notes:

- 1) The bandwidth capability of components and instruments used to display the pulse generator output signal (attenuators, cables, connectors, etc.) should exceed one gigahertz.
- 2) The use of 40 db attenuator will insure a peak input signal to the sampling scope of less than one volt.
- 3) When triggering the AVMR-2 from a high speed lab pulse generator it may be necessary to shunt the input to the AVMR-2 by a 50 ohm resistor to eliminate reflection which may interfere with the operation of the lab pulse generator.
- 4) In general, the source pulse generator trigger delay control should be set in the 0.1 to 1.0 usec range. Other settings should be as shown in the above diagram.
- 5) **WARNING:** Model AVMR-2 may fail if triggered at a PRF greater than 10 MHz or if the duty cycle exceeds 20% or if the PW exceeds 200 nsec.
- 6) The output amplitude is controlled by means of the one turn potentiometer (AMP).
- 7) The output pulse width is approximately equal to the input pulse width.
- 8) With the TR switch in the L position, the unit provides an output rise time of 300 psec. With the TR switch in the H position, the rise time is about 3 nsec.
- 9) The TF switch provides a fall time of 300 psec when in the L position and a fall time of 3 nsec when in the H position.
- 10) The required output DC offset voltage is applied to the rear panel OS solder terminals (+50 volts, 100 mA max).
- 11) The P OUT port provides a positive output pulse. To obtain a negative output pulse, connect the P OUT port to the N IN port using a short length of 50 ohm semi-rigid cable. A negative pulse is then obtained at the N OUT port. (PN option).

## SYSTEM DESCRIPTION AND REPAIR PROCEDURE

The AVMR-2-PS-PW consists of a pulse generator module (AVMR-2-PW-PG) and a power supply board which supplies +24 volts (600 mA max) to the pulse generator module. In the event that the unit malfunctions, remove the instrument cover by removing the four Phillips screws on the back side of the unit. The top lid may then be slid off. Measure the voltage at the +24V pin of the PG module. If this voltage is substantially less than +24 volts, unsolder the line connecting the power supply and PG modules and connect 50 ohm 10 W load to the PS output. The voltage across this load should be about +24 V DC. If this voltage is substantially less than 24 volts the PS module is defective and should be repaired or replaced. If the voltage across the resistor is near 24 volts, then the PG module should be replaced or repaired. The sealed PG module must be returned to Avtech for repair (or replacement).

SYSTEM BLOCK DIAGRAM

