

AVTECH ELECTROSYSTEMS LTD.

NANOSECOND WAVEFORM ELECTRONICS
ENGINEERING - MANUFACTURING

□ P.O. BOX 265
OGDENSBURG
NEW YORK
13669
(315) 472-5270

☒ BOX 5120, STN. "F"
OTTAWA, ONTARIO
CANADA K2C 3H4
TEL: (613) 226-5772
FAX: (613) 226-2802
TELEX: 053-4591

INSTRUCTIONS

MODEL AVN-1 PULSE GENERATOR

S.N. :

WARRANTY

Avtech Electrosystems Ltd. warrants products of its manufacture to be free from defects in material and workmanship under conditions of normal use. If, within one year after delivery to the original owner, and after prepaid return by the original owner, this Avtech product is found to be defective, Avtech shall at its option repair or replace said defective item. This warranty does not apply to units which have been disassembled, modified or subjected to conditions exceeding the applicable specifications or ratings. This warranty is the extent of the obligation or liability assumed by Avtech with respect to this product and no other warranty or guarantee is either expressed or implied.

MODEL AVN-1 PULSE GENERATOR TEST ARRANGEMENT

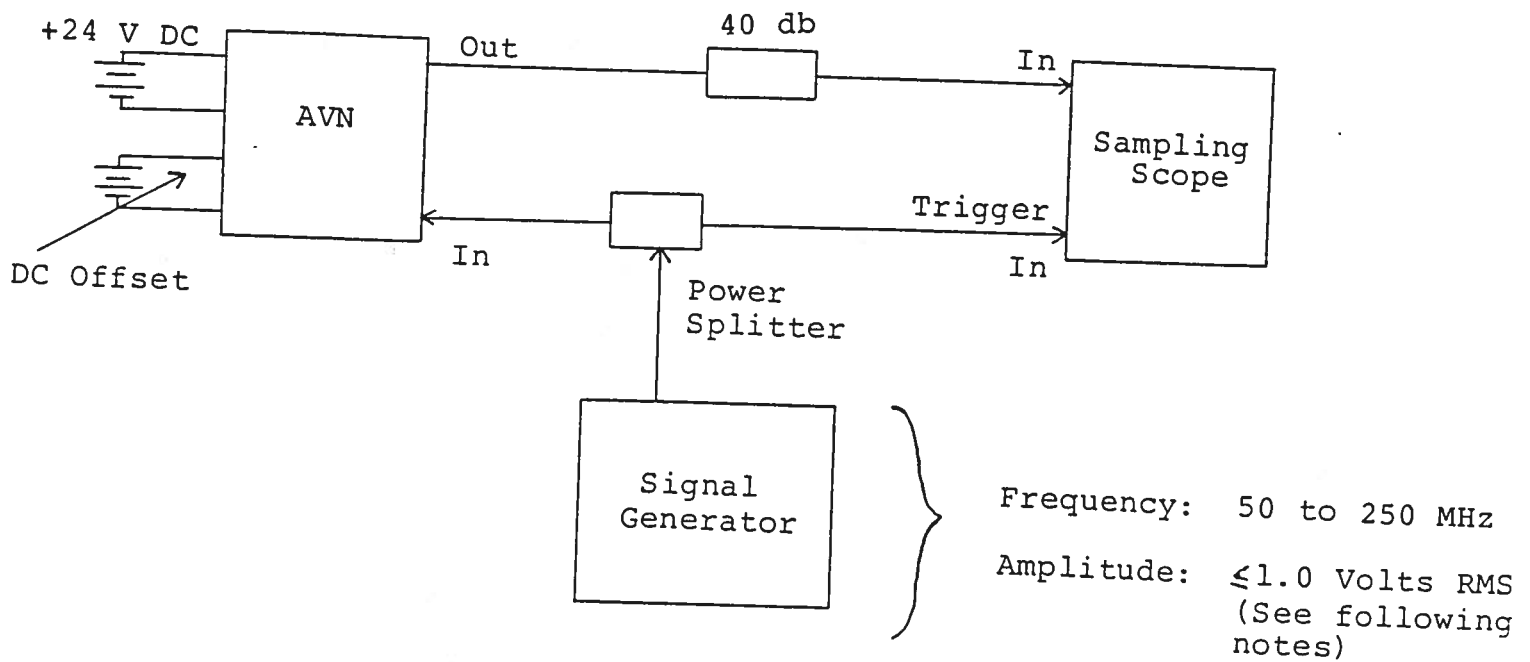

SUGGESTED OPERATING PROCEDURE

- 1) The bandwidth capability of components and instruments used to display the pulse generator output signal (attenuators, cables, connectors, etc.) should exceed ten gigahertz.
- 2) The use of a 40 db attenuation will insure a peak input signal to the sampling scope of less than 1.0 volt.
- 3) The AVN unit prime power consumption is +24 V DC with a current as high as 0.40 Amps, depending on the input drive level. It is recommended that the unit be bolted to a chassis wherever possible to maintain a low operating temperature.
- 4) Connect equipment as shown above and apply +24 DC supply to rear panel solder terminals.
- 5) The output pulse shape is determined by the two front panel pot controls TR and TF, TR controls the leading edge of the pulse while TF controls the falling edge. Clockwise rotation of TR and TF increases the output pulse width. Initially rotate the TF pot fully clockwise and set the TR pot at mid-range.
- 6) The AVN output amplitude varies directly with the sinewave input level and therefore can be varied over the range by varying the input signal level or by means of the Amp pot. The supply current to the AVN unit increases with the input drive level and in no case should exceed 0.45 Amps since overheating may occur. The necessary signal generator output level may be established as follows. The signal generator output level should be turned down to zero and tuned to the desired frequency in the range of 50 - 250 MHz (output PRF = input frequency) before connecting to the AVN unit. After connecting, increase the signal generator output until an AVN peak output near the desired amplitude is observed on the scope. The CRT display will resemble the following:

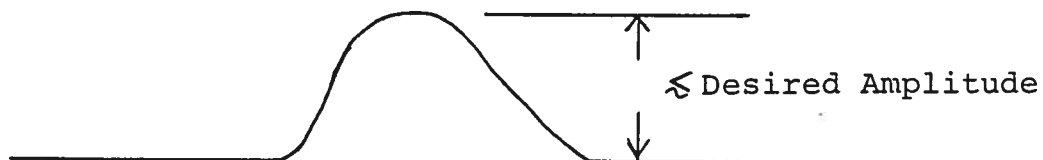

While increasing the signal generator output simultaneously insure that the AVN supply current does not exceed 0.45 Amps.

- 7) Having obtained a display of the form shown in 3) above, the desired pulse width is then obtained by adjusting the two front panel pots TR and TF. Rotate TR counter clockwise from the positive set in step 2) until a sharp 100 psec leading edge is observed. Then rotate TF counterclockwise until the desired pulse width and fall time are obtained.

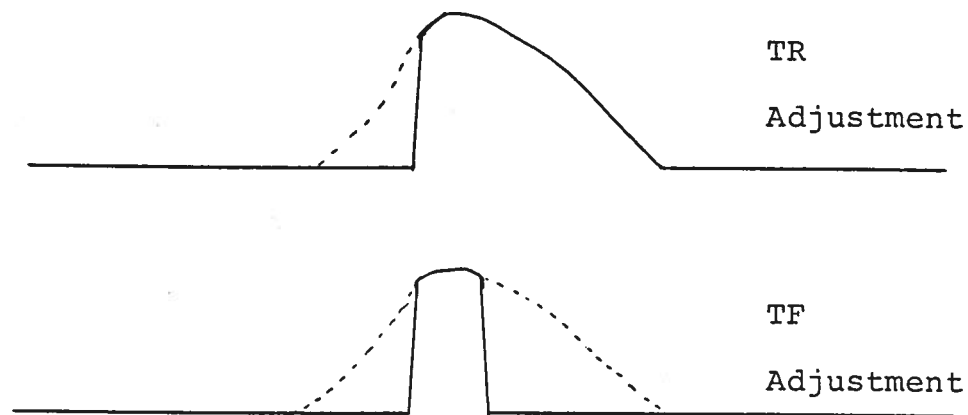

Further iterative adjustments of TR and TF will be necessary to simultaneously obtain the lowest rise time, lowest fall time, the desired pulse width, and pulse top shape, and low spurious signal level. In addition some additional adjustment of input signal level may be necessary to obtain the desired amplitude. If the input frequency is then changed it will be necessary to readjust TR and TF to establish the required pulse shape and it will be necessary to adjust the drive level to obtain the desired output amplitude and to insure that the input supply current does not exceed 0.45 Amps. Following the above sequence it is possible to generate output pulses having amplitudes of at least 15 volts with variable pulse width (at least from 300 to 1000 psec) with pulse repetition frequencies in the range of 50 to 100 MHz. The unit will operate to at least 250 MHz and with reduced output (5 volts). **WARNING:** Do not operate below 50 MHz as failure may result.

- 8) A DC offset (± 50 V max, 200 mA max) can be added to the AVN output pulse by applying the desired DC level to the DC offset solder terminals on the back panel of the instrument.

04.20.90

11

[Faint, illegible text, possibly bleed-through from the reverse side of the page]