

AVTECH ELECTROSYSTEMS LTD.

NANOSECOND WAVEFORM ELECTRONICS
ENGINEERING - MANUFACTURING

□ P.O. BOX 265
OGDENSBURG
NEW YORK
13669
(315) 472-5270

☒ BOX 5120, STN. "F"
OTTAWA, ONTARIO
CANADA K2C 3H4
TEL: (613) 226-5772
FAX: (613) 226-2802
TELEX: 053-4591

INSTRUCTIONS

MODEL AVN-1-PS PULSE GENERATOR

S.N.:

WARRANTY

Avtech Electrosystems Ltd. warrants products of its manufacture to be free from defects in material and workmanship under conditions of normal use. If, within one year after delivery to the original owner, and after prepaid return by the original owner, this Avtech product is found to be defective, Avtech shall at its option repair or replace said defective item. This warranty does not apply to units which have been disassembled, modified or subjected to conditions exceeding the applicable specifications or ratings. This warranty is the extent of the obligation or liability assumed by Avtech with respect to this product and no other warranty or guarantee is either expressed or implied.

MODEL AVN-PS PULSE GENERATOR TEST ARRANGEMENT

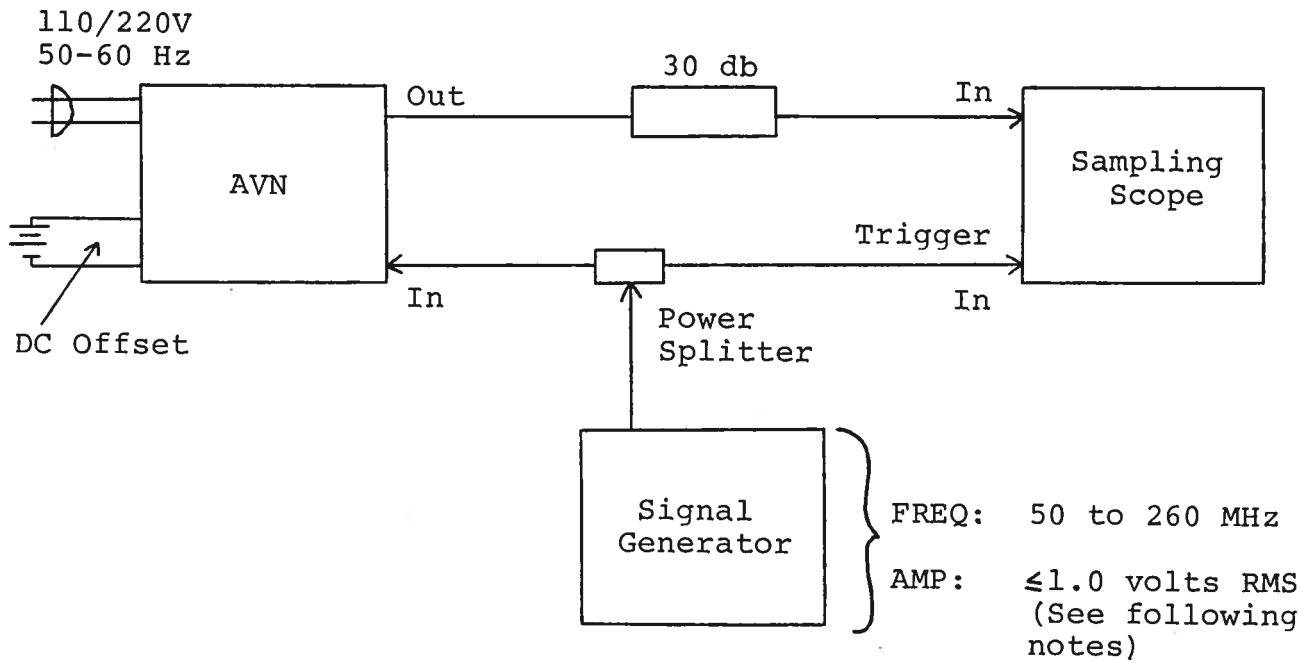

Notes:

- 1) The bandwidth capability of components and instruments used to display the pulse generator output signal (attenuators, cables, connectors, etc.) should exceed ten gigahertz.
- 2) The use of a 30 db attenuation will insure a peak input signal to the sampling scope of less than 1.0 volt.

SUGGESTED OPERATING PROCEDURE

- 1) Connect equipment as shown above.
- 2) The output pulse shape is determined by the two front panel pot controls TR and TF, TR controls the leading edge of the pulse while TF controls the falling edge. Clockwise rotation of TR and TF increases the output pulse width. Initially rotate the TF pot fully clockwise and set the TR pot at mid-range. The output amplitude is controlled by the input drive amplitude and by the AMP control. Initially the AMP control should be set max clockwise.
- 3) The AVN output amplitude varies directly with the sinewave input level and therefore can be varied over the range of 0 to 5 volts by varying the input signal level. WARNING: In no case should the signal generator output (to a match 50 ohm load) exceed 1.0 volts RMS. The necessary signal generator output level may be established as follows. The signal generator output level should be turned down to zero and tuned to the desired frequency in the range of 50 - 260 MHz (output PRF = input frequency) before connecting to the AVN unit. After connecting, increase the signal generator output until an AVN peak output near the desired amplitude is observed on the scope. The CRT display will resemble the following:



- 4) Having obtained a display of the form shown in 3) above, the desired pulse width is then obtained by adjusting the two front panel pots TR and TF. Rotate TR counter clockwise from the positive set in step 2) until a sharp 100 psec leading edge is observed. Then rotate TF counterclockwise until the desired pulse width and fall time are obtained.

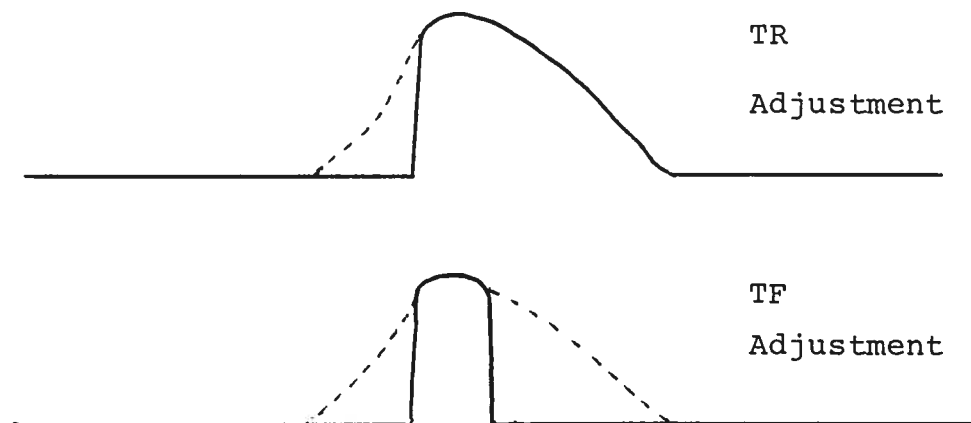

Further iterative adjustments of TR and TF will be necessary to simultaneously obtain the lowest rise time, lowest fall time, the desired pulse width, and pulse top shape, and low spurious signal level. In addition some additional adjustment of input signal level may be necessary to obtain the desired amplitude. If the input frequency is then changed it will be necessary to readjust TR and TF to establish the required pulse shape and it will be necessary to adjust the drive level to obtain the desired output amplitude. Following the above sequence it is possible to generate output pulses having amplitudes of at least 5 volts with variable pulse width (at least from 300 to 1000 psec) with pulse repetition frequencies in the range of 50 to 260 MHz. The unit will operate to at least 280 MHz and beyond with reduced output. WARNING: Do not operate below 50 MHz as failure may result.

- 5) Steps 3 and 4 may be simplified by setting the signal generator outputs at 0.3 V RMS to 1.0 V RMS and subsequently using only the AMP control to set the output pulse amplitude.
- 6) For units with the QT or EQ options, the output DC offset is variable from +5 to -5 volts by means of the front panel one turn OFFSET control. The offset control may be turned off by means of the rear panel ON-OFF OFFSET switch.
- 7) The monitor output port (M) provides an attenuated ($\times 10$) coincident replica of the output to a fifty ohm load. (option).

C

SYSTEM BLOCK DIAGRAM AND REPAIR PROCEDURE

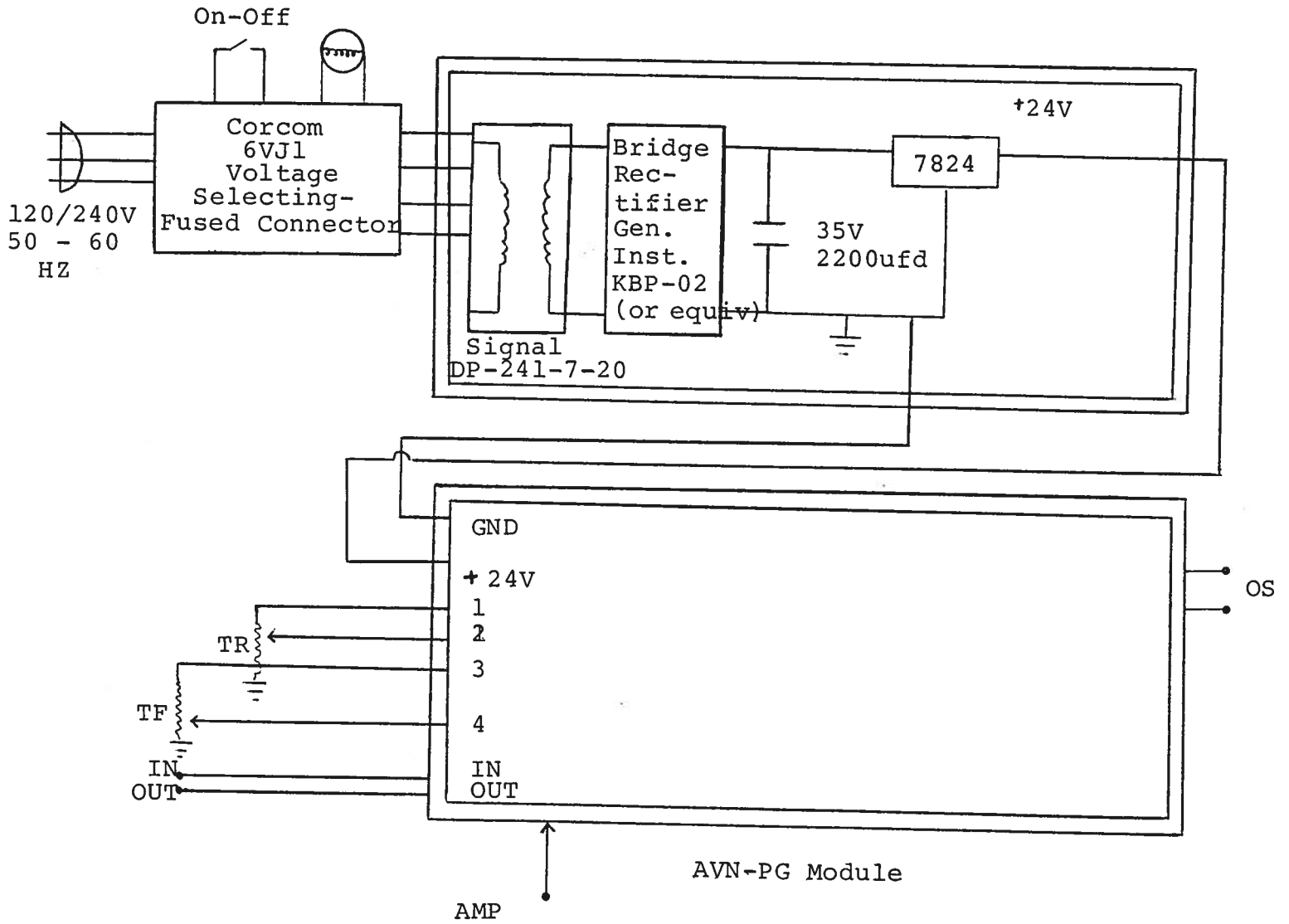

SYSTEM DESCRIPTION AND REPAIR PROCEDURE

The AVN-PS consists of a pulse generator module (AVN-PG) and a power supply board which supplies +24 volts (600 mA max) to the pulse generator module. In the event that the AVN-PS unit malfunctions, remove the instrument cover by removing the four Phillips screws on the back of the unit. The top lid may then be slid off. Measure the voltage at the +24 V pin of the PG module. If this voltage is substantially less than +24 volts, unsolder the line connecting the power supply and PG modules and connect 50 ohm 10 W load to the PS output. The voltage across this load should be about +24 V DC. If this voltage is substantially less than 24 volts the PS module is defective and should be repaired or replaced. If the voltage across the resistor is near 24 volts, then the PG module should be replaced or repaired. The sealed PG module must be returned to Avtech for repair (or replacement).

Schroff

04.26.90

-OT

-EO

-M