



AVTECH ELECTROSYSTEMS LTD.

NANOSECOND WAVEFORM ELECTRONICS
SINCE 1975

□ P.O. BOX 265
OGDENSBURG, NY
U.S.A. 13669-0265
TEL: (315) 472-5270
FAX: (613) 226-2802

TEL: 1-800-265-6681
FAX: 1-800-561-1970
U.S.A. & CANADA

□ BOX 5120 STN. F
OTTAWA, ONTARIO
CANADA K2C 3H4
TEL: (613) 226-5772
FAX: (613) 226-2802

INSTRUCTIONS

MODEL AVN-3-PS-N-M6 PULSE GENERATOR

S.N. :

WARRANTY

Avtech Electrosystems Ltd. warrants products of its manufacture to be free from defects in material and workmanship under conditions of normal use. If, within one year after delivery to the original owner, and after prepaid return by the original owner, this Avtech product is found to be defective, Avtech shall at its option repair or replace said defective item. This warranty does not apply to units which have been disassembled, modified or subjected to conditions exceeding the applicable specifications or ratings. This warranty is the extent of the obligation or liability assumed by Avtech with respect to this product and no other warranty or guarantee is either expressed or implied.

MODEL AVN-PS PULSE GENERATOR TEST ARRANGEMENT

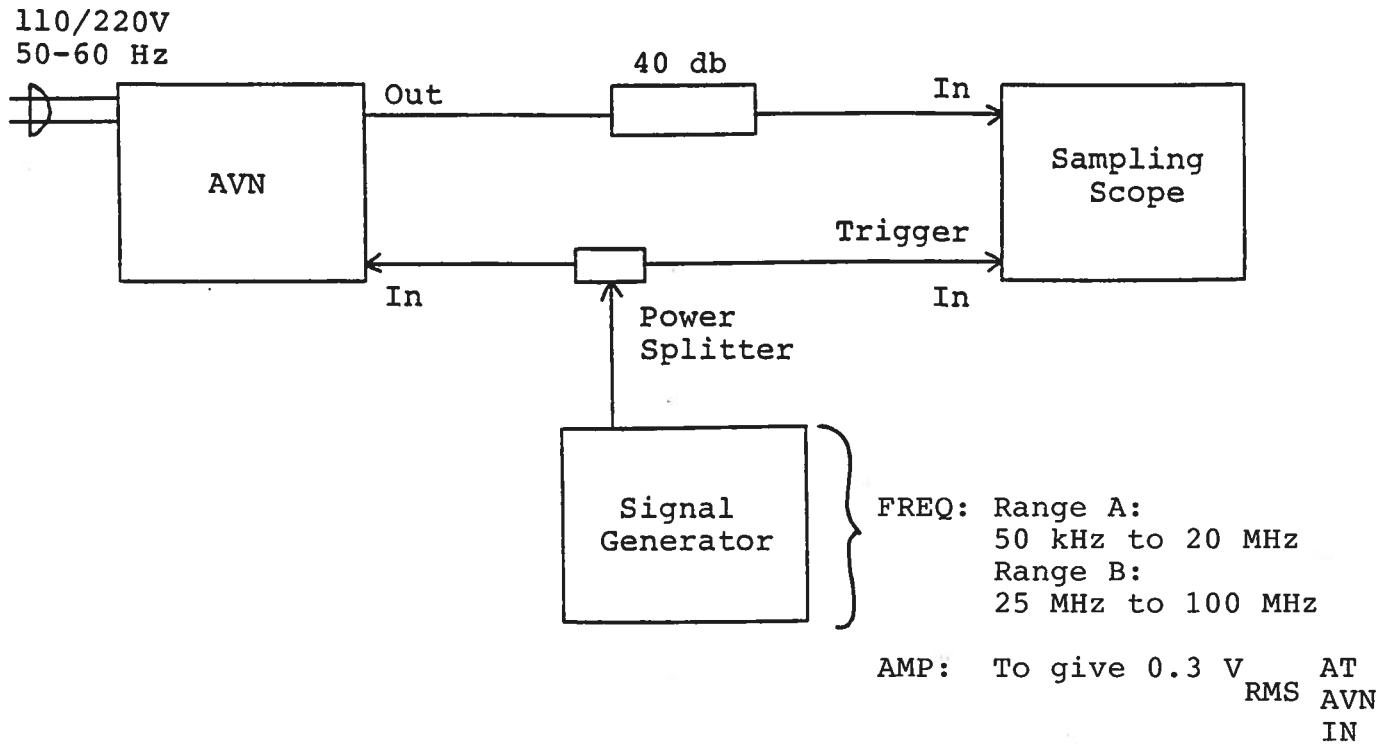

Notes:

- 1) The bandwidth capability of components and instruments used to display the pulse generator output signal (attenuators, cables, connectors, etc.) should exceed ten gigahertz.
- 2) The use of a 40 dB attenuation will insure a peak input signal to the sampling scope of less than 1.0 Volt.

SUGGESTED OPERATING PROCEDURE

RANGE A

- 1) Connect the equipment as shown above and set the RANGE switch to the A position. Insure that the frequency is in the range of 50 kHz to 20 MHz and that the input amplitude is 0.3 V_{RMS}. Set the amplitude and pulse width controls fully clockwise.
- 2) An output pulse having an amplitude of about 18 Volts should be observed. Adjust the pulse width control to obtain the desired 200 ps pulse width. Some iterative adjustments of the pulse width and amplitude controls may be necessary to obtain the final waveform. Further adjustments will be necessary if the PRF is changed.
- 3) A DC offset (± 50 V max, ± 200 mA max) can be added to the AVN output pulse by applying the desired DC level to the DC offset solder terminals on the back panel of the instrument.
- 4) CAUTION: The unit may be damaged if the RANGE A input is higher than 20 MHz. Also note that the overload protection function may turn off the instrument if attempts are made to operate at pulse widths significantly higher than 200 ps and with amplitudes in excess of 18 Volts. If the overload light keeps coming on, then rotate the amplitude and pulse width controls counter clockwise until the overload ceases to function.

RANGE B

- 1) Connect equipment as shown above and set the RANGE switch in the B position. Insure that frequency is not less than 25 MHz as this may result in damage to the AVN unit.
- 2) The output pulse shape is determined by the two front panel pot controls TR and TF, TR controls the leading edge of the pulse while TF controls the falling edge. Clockwise rotation of TR and TF increases the output pulse width. Initially rotate the TF pot fully clockwise and set the TR pot at mid-range. The output amplitude is controlled by the AMP control. Initially the AMP control should be set max clockwise and the AVN input amplitude set to $0.3 V_{RMS}$. The output waveform should resemble the following:

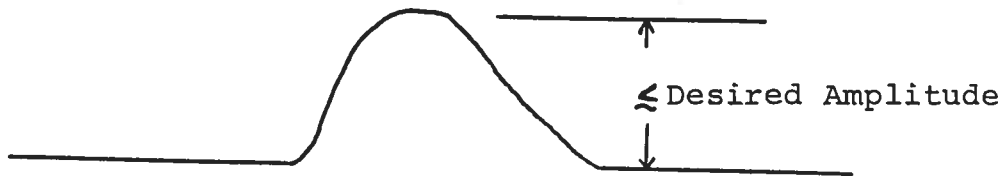

Further iterative adjustments of TR, TF and AMP will be necessary to simultaneously obtain the lowest rise time, lowest fall time, the desired pulse width, the desired amplitude and pulse top shape, and low spurious signal level. If the input frequency is then changed it will be necessary to readjust TR and TF to establish the required pulse shape and it will be necessary to adjust the AMP control to obtain the desired output amplitude. Following the above sequence it is possible to generate output pulses having amplitudes of at least 18 Volts with variable pulse width (at least from 200 to 500 ps) with pulse repetition frequencies in the range of 25 to 100 MHz. WARNING: Do not operate below 25 MHz as failure may result.

- 4) A DC offset (± 50 V max, 200 mA max) can be added to the AVN output pulse by applying the desired DC level to the DC offset solder terminals on the back panel of the instrument.
- 5) CAUTION: The overload protection function may turn off the instrument if attempts are made to operate at pulse widths significantly higher than 200 ps and with amplitudes in excess of 18 Volts. If the overload light keeps coming on, then reduce the amplitude and pulse width until the overload ceases to function.

C

SYSTEM BLOCK DIAGRAM AND REPAIR PROCEDURE

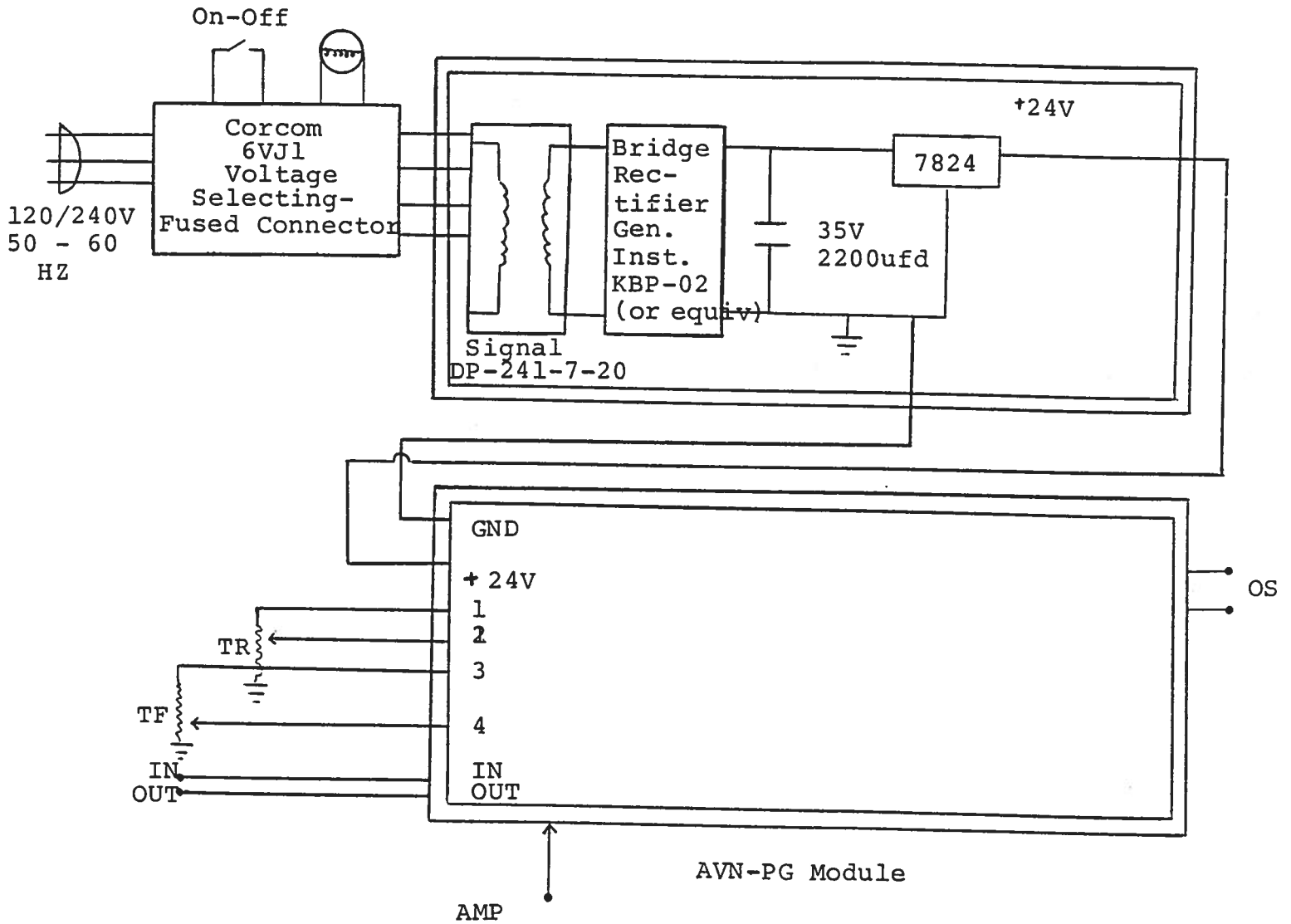

SYSTEM DESCRIPTION AND REPAIR PROCEDURE

The AVN-PS consists of a pulse generator module (AVN-PG) and a power supply board which supplies +24 Volts (600 mA max) to the pulse generator module. In the event that the AVN-PS unit malfunctions, remove the instrument cover by removing the four Phillips screws on the back of the unit. The top lid may then be slid off. Measure the voltage at the +24 V pin of the PG module. If this voltage is substantially less than +24 Volts, unsolder the line connecting the power supply and PG modules and connect 50 Ohm 10 W load to the PS output. The voltage across this load should be about +24 V DC. If this voltage is substantially less than 24 Volts the PS module is defective and should be repaired or replaced. If the voltage across the resistor is near 24 Volts, then the PG module should be replaced or repaired. The sealed PG module must be returned to Avtech for repair (or replacement).

Sept. 13/1941