



AVTECH ELECTROSYSTEMS LTD.

NANOSECOND WAVEFORM ELECTRONICS
SINCE 1975

P.O. BOX 265
OGDENSBURG, NY
U.S.A. 13669-0265
TEL: (315) 472-5270
FAX: (613) 226-2802

TEL: 1-800-265-6681
FAX: 1-800-561-1970

e-mail: info@avtechpulse.com
<http://www.avtechpulse.com>

P.O. BOX 5120 STN. F
OTTAWA, ONTARIO
CANADA K2C 3H4
TEL: (613) 226-5772
FAX: (613) 226-2802

INSTRUCTIONS

MODEL AVNC-2-C-RAY1 PULSE GENERATOR

S.N.:

WARRANTY

Avtech Electrosystems Ltd. warrants products of its manufacture to be free from defects in material and workmanship under conditions of normal use. If, within one year after delivery to the original owner, and after prepaid return by the original owner, this Avtech product is found to be defective, Avtech shall at its option repair or replace said defective item. This warranty does not apply to units which have been disassembled, modified or subjected to conditions exceeding the applicable specifications or ratings. This warranty is the extent of the obligation assumed by Avtech with respect to this product and no other warranty or guarantee is either expressed or implied.

TECHNICAL SUPPORT

Phone: 613-226-5772 or 1-800-265-6681

Fax: 613-226-2802 or 1-800-561-1970

E-mail: info@avtechpulse.com

World Wide Web: <http://www.avtechpulse.com>

TABLE OF CONTENTS

WARRANTY.....	2
TABLE OF CONTENTS	3
FIG. 1: PULSE GENERATOR TEST ARRANGEMENT.....	4
GENERAL OPERATING INSTRUCTIONS	5
FIG. 2 FRONT PANEL CONTROLS	6
FRONT PANEL CONTROLS	7
FIG. 3 BACK PANEL CONTROLS.....	8
BACK PANEL CONTROLS.....	9
FIG. 4 SYSTEM BLOCK DIAGRAM.....	10
FIG. 5 SYSTEM BLOCK DIAGRAM AVNC-2-C.....	11
FIG. 6 SYSTEM BLOCK DIAGRAM AVNC-2-C-EF	12
PERFORMANCE CHECK SHEET	13

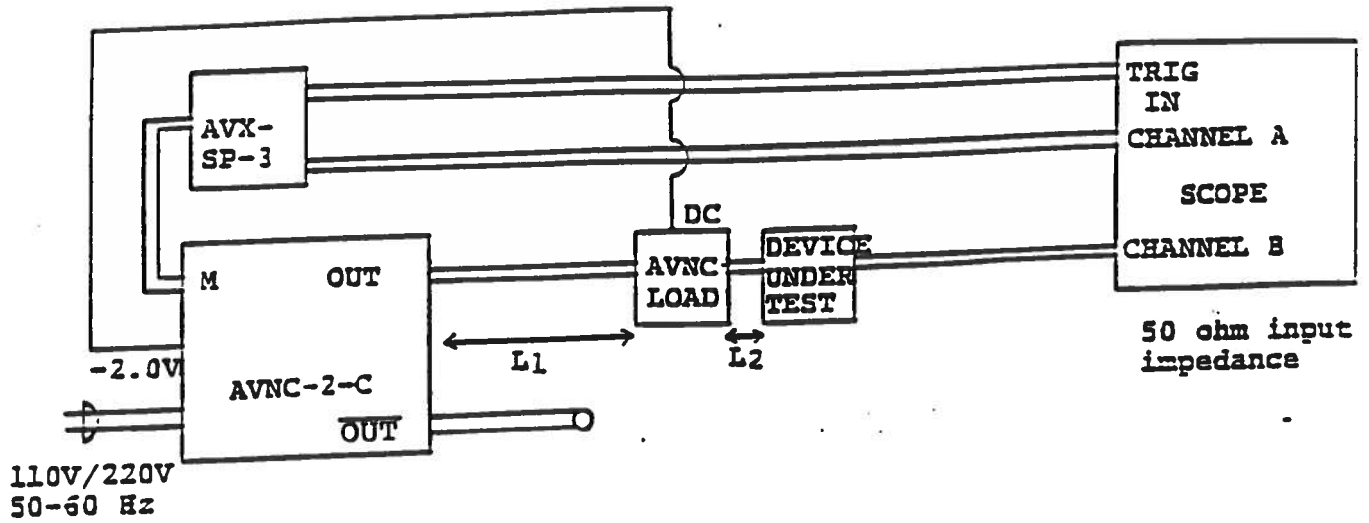
FIG. 1: PULSE GENERATOR TEST ARRANGEMENT

GENERAL OPERATING INSTRUCTIONS

- 1) The bandwidth capability of components and instruments used to display the pulse generator output signal (attenuators, cables, connectors, etc.) should exceed one gigahertz.
- 2) The device under test should be placed directly in the output of the AVNC-LOAD module. The length of 50 Ohm line L_2 should not exceed several inches or the resulting reflection from the device under test will distort the ECL level waveforms. The length of 50 Ohm line L_1 can be of any length. The AVNC-LOAD module contains the 50 Ohm -2.0 Volt termination required by the AVNC pulse generator. The -2.0 Volt is supplied from the rear panel of the AVNC mainframe.
- 3) The back panel M port provides a coincident attenuated replica (x10 to 50 Ohms) of the front panel output A or output B. The use of an Avtech AVX-SP-3 power splitter connected at the M output provides a convenient means for triggering the time bases of the oscilloscope and for displaying a replica of the output pulse. It is essential that the output ports of the AVX-SP-3 unit be terminated in 50 Ohms. Note that in the absence of an AVX-SP-3, the M ports may be connected directly to the TRIG IN port of the scope (use 50 Ohm termination).
- 4) The front panel output provides a -0.9, -1.8 Volt level ECL square wave (to 50 Ohms, -2.0 Volts) covering the PRF range of 10 kHz to 50 MHz when the front panel PRF range switch is in the A position. The PRF is controlled by the six position PRF RANGE A switch and the ten turn PRF A control.
- 5) The front panel output provides a -0.9, -1.8 Volt level ECL square wave (to 50 Ohms, -2.0 Volts) covering the PRF range of 50 MHz to 250 MHz when the front panel PRF range switch is in the B position. The PRF is controlled by the three position PRF RANGE B switch and the ten turn PRF B control.
- 6) The AVNC-C unit can be converted from 110 to 220V 50-60 Hz operation by adjusting the voltage selector card in the rear panel fused voltage selector-cable connector assembly.
- 7) For additional assistance:

Tel: (613) 226-5772
Fax: (613) 226-2802

FIG. 2 FRONT PANEL CONTROLS

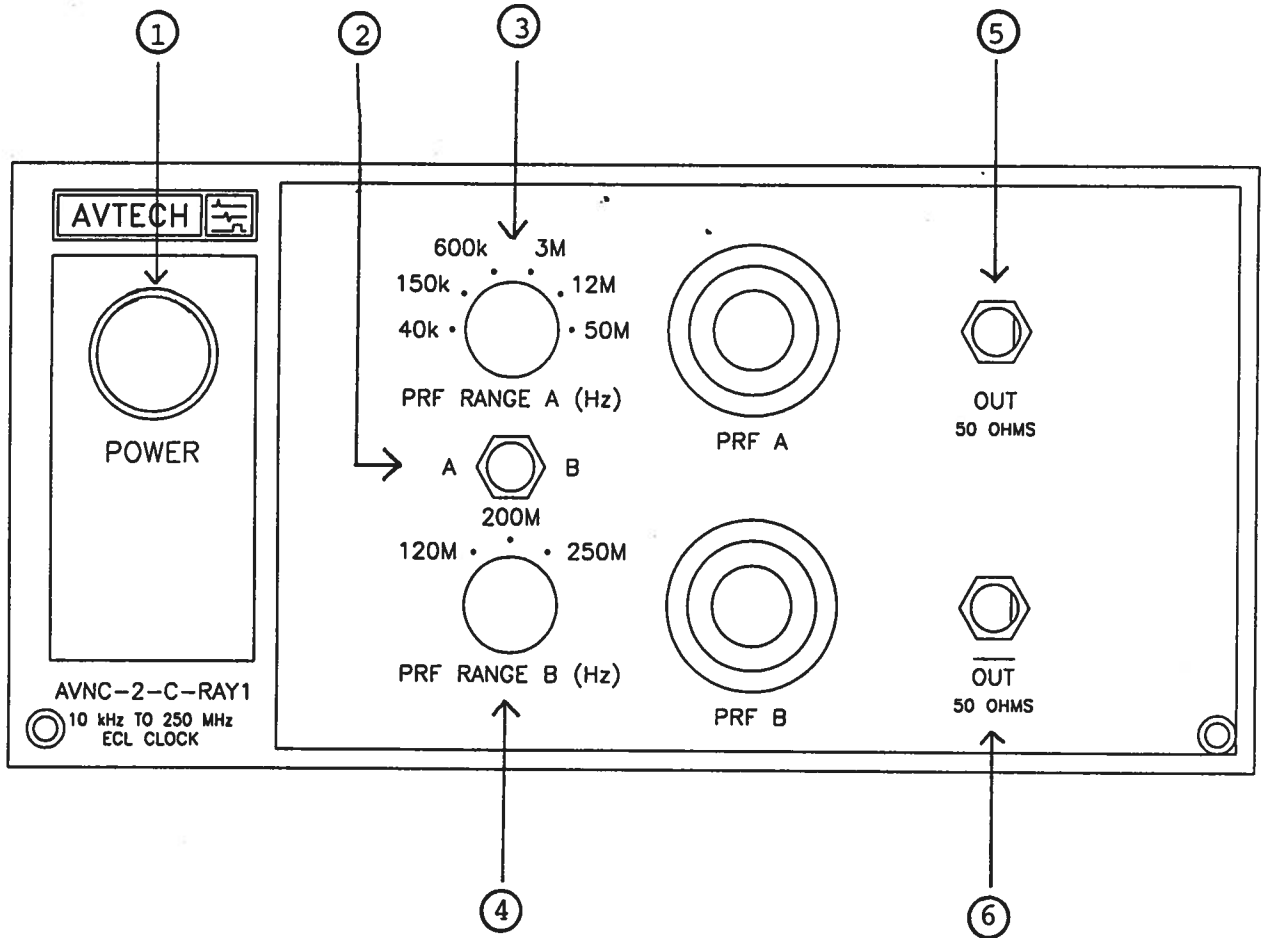

FRONT PANEL CONTROLS

- (1) ON-OFF Switch. Applies basic prime power to all stages.
- (2) RANGE A-B. When switch is in A position, output provides square wave pulses covering PRF range of 10 kHz to 50 MHz. When switch in B position, output provides square wave pulses covering PRF range of 50 MHz to 250 MHz.
- (3) PRF A Control. PRF RANGE A and PRF FINE A controls output A PRF as follows:

	PRF MIN	PRF MAX
Range 1	10 kHz	40 kHz
Range 2	40 kHz	150 kHz
Range 3	150 kHz	600 kHz
Range 4	600 kHz	3 MHz
Range 5	3 MHz	12 MHz
Range 6	12 MHz	50 MHz

- (4) PRF B Control. PRF RANGE B and PRF FINE B control output B PRF as follows:

	PRF MIN	PRF MAX
Range 1	40 MHz	120 MHz
Range 2	50 MHz	200 MHz
Range 3	100 MHz	250 MHz

Note that when in Range 3, the ten turn PRF fine control is active only in the range of about 2.0 to 7.0.

- (5) OUTPUT. Provides a -0.9, -1.8 Volt level ECL square wave (to 50 Ohms, -2.0 Volts) covering the PRF range of 10 kHz to 250 MHz.
- (6) $\overline{\text{OUTPUT}}$. Provides the complement of (5).

FIG. 3 BACK PANEL CONTROLS

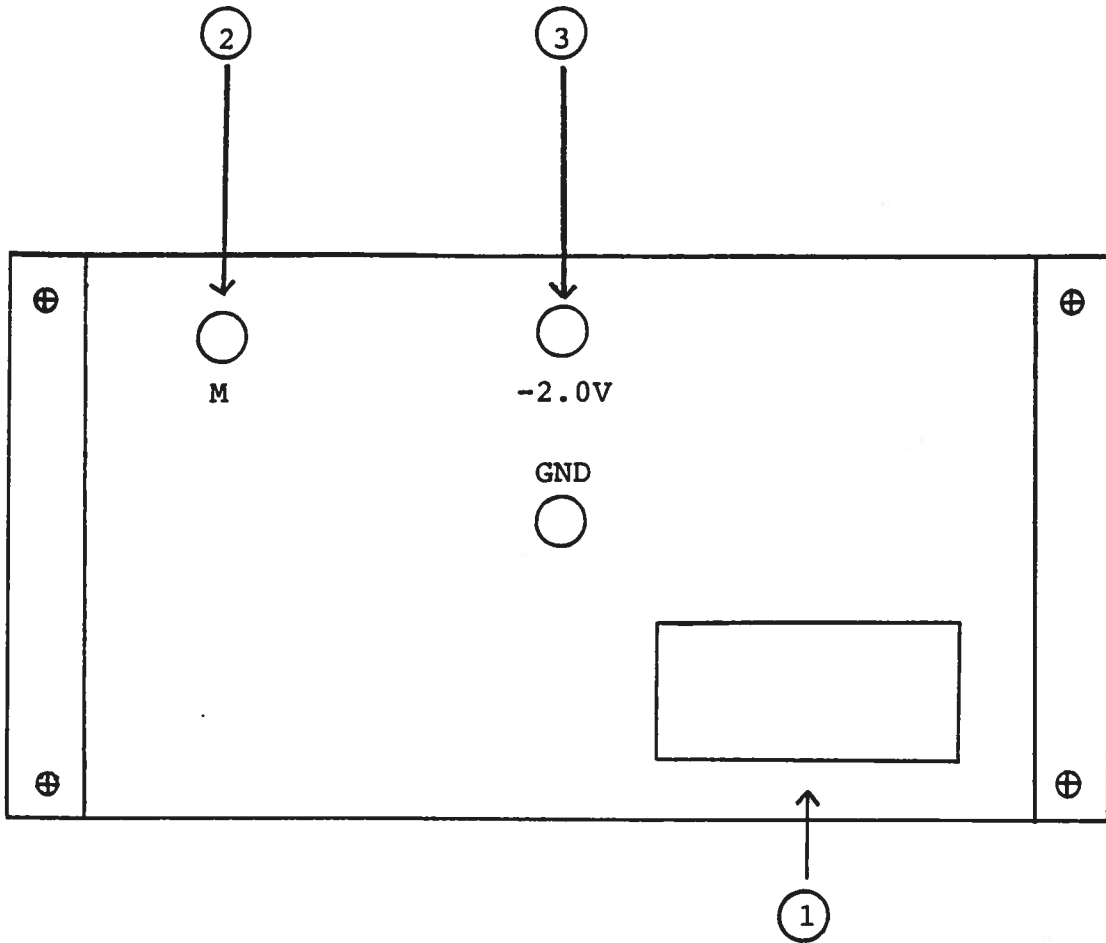

BACK PANEL CONTROLS

- (1) FUSED CONNECTOR, VOLTAGE SELECTOR. The detachable power cord is connected at this point. In addition, the removable cord is adjusted to select the desired input operating voltage. The unit also contains the main power fuse (0.25 A SB).
- (2) MONITOR OUT. Provides an attenuated (x10) coincident replica of output to fifty Ohms.
- (3) -2.0V OUT. Connect to DC terminal of AVNC-LOAD module which is connected to output of AVNC mainframe.

FIG. 4 SYSTEM BLOCK DIAGRAM

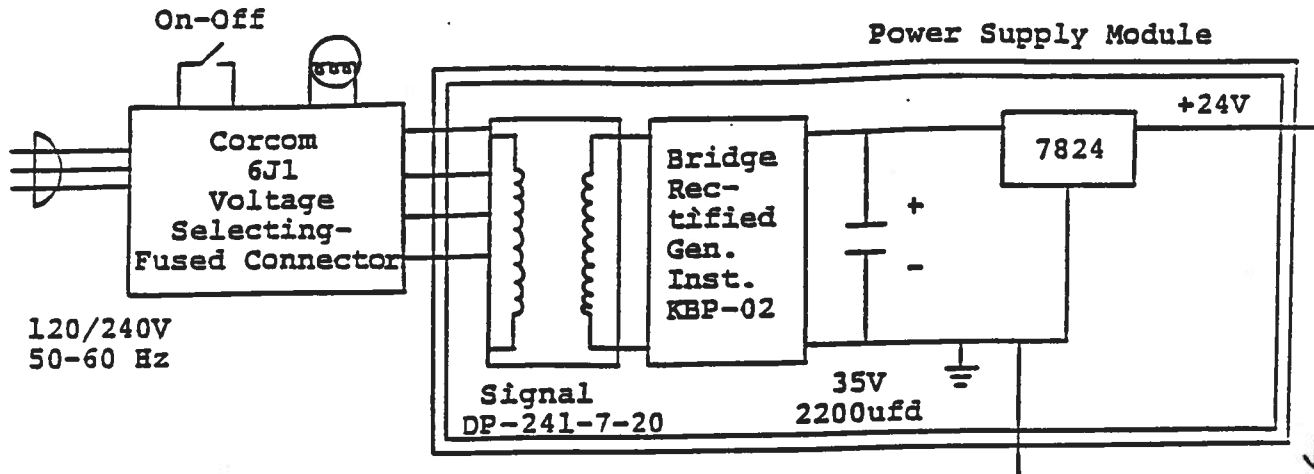

FIG. 5 SYSTEM BLOCK DIAGRAM AVNC-2-C

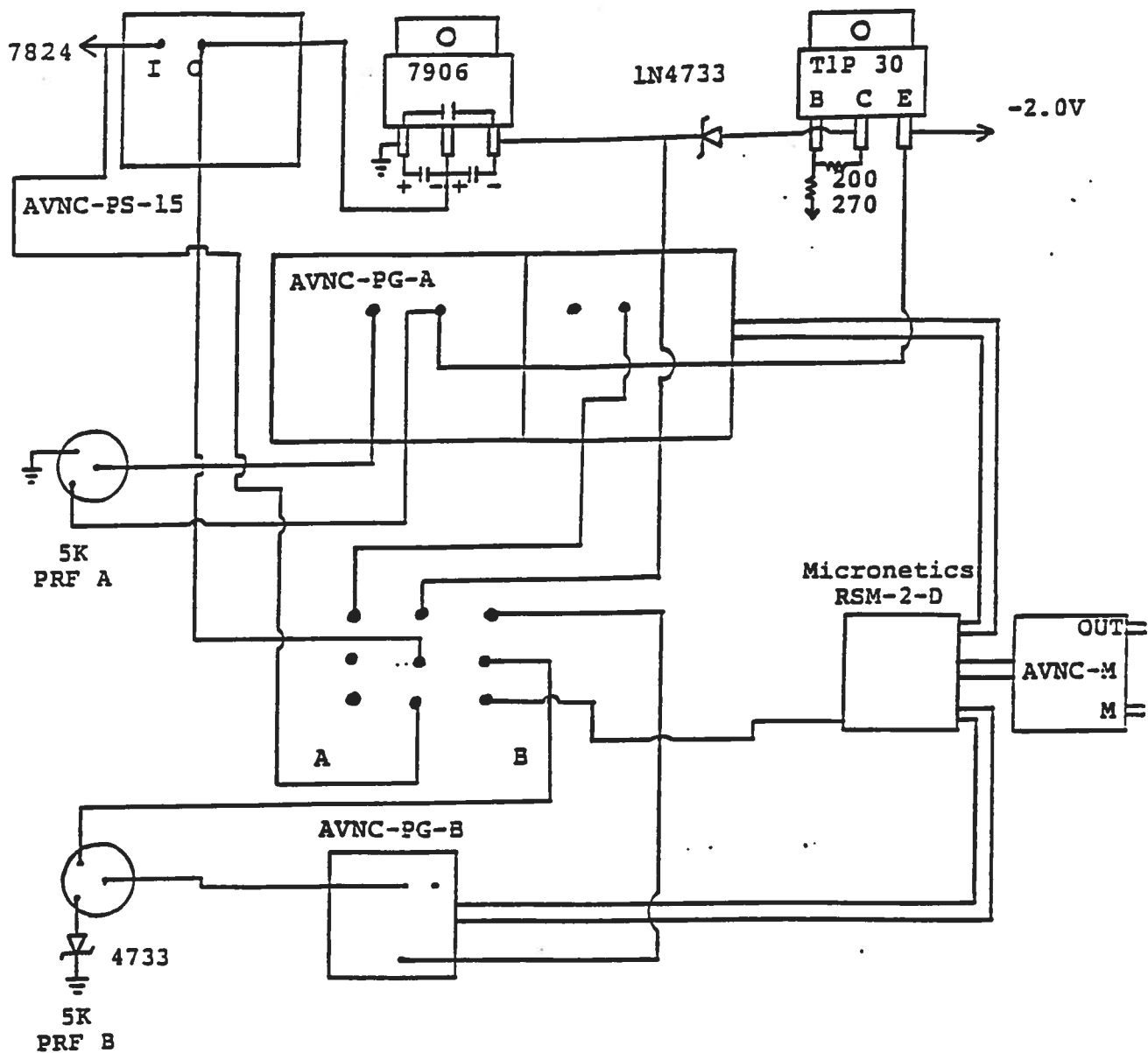

FIG. 6 SYSTEM BLOCK DIAGRAM AVNC-2-C-EF

