



AVTECH ELECTROSYSTEMS LTD.

NANOSECOND WAVEFORM ELECTRONICS
SINCE 1975

P.O. BOX 265
OGDENSBURG, NY
U.S.A. 13669-0265
TEL: (315) 472-5270
FAX: (613) 226-2802

TEL: 1-800-265-6681
FAX: 1-800-561-1970
U.S.A. & CANADA

e-mail: info@avtechpulse.com

BOX 5120 STN. F
OTTAWA, ONTARIO
CANADA K2C 3H4
TEL: (613) 226-5772
FAX: (613) 226-2802

INSTRUCTIONS

MODEL AVNN-C PULSE GENERATOR

S.N.:

WARRANTY

Avtech Electrosystems Ltd. warrants products of its manufacture to be free from defects in material and workmanship under conditions of normal use. If, within one year after delivery to the original owner, and after prepaid return by the original owner, this Avtech product is found to be defective, Avtech shall at its option repair or replace said defective item. This warranty does not apply to units which have been disassembled, modified or subjected to conditions exceeding the applicable specifications or ratings. This warranty is the extent of the obligation or liability assumed by Avtech with respect to this product and no other warranty or guarantee is either expressed or implied.

Fig. 1

PULSE GENERATOR TEST ARRANGEMENT

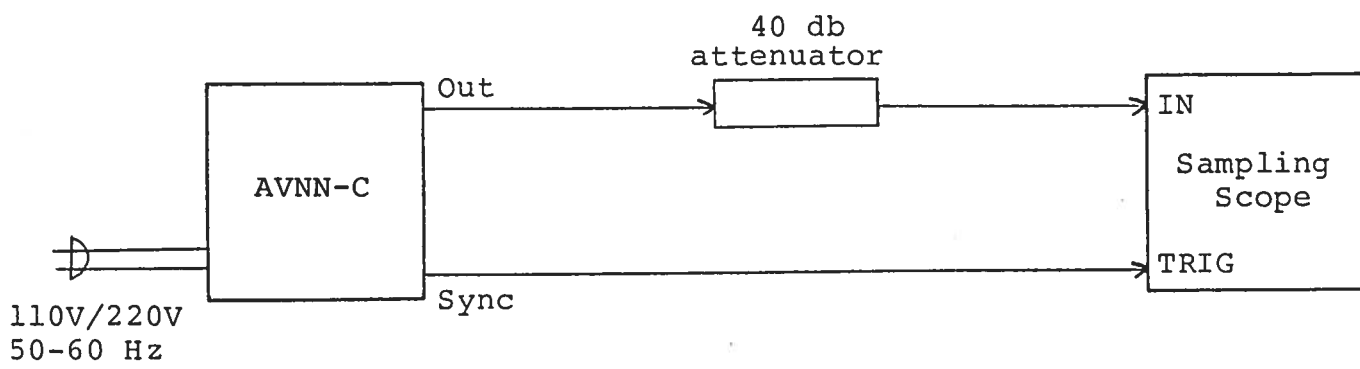

Notes:

- 1) The bandwidth capability of components and instruments used to display the pulse generator output signal (attenuators, cables, connectors, etc.) should exceed ten gigahertz.
- 2) The use of 40 dB attenuator at the sampling scope vertical input channel will insure a peak input signal to the sampling scope of less than one Volt.
- 3) The SYNC output provides a 50 mV sine wave (to 50 Ohms).
- 4) To obtain a stable output display the PRF RANGE and PRF controls on the front panel should be set mid-range while the FREQUENCY RANGE switch may be in either range. The front panel TRIG toggle switch should be in the INT position. The pulse width control should be set mid-range while the amplitude and TR-TF controls should be set maximum clockwise. The prime power should be turned on and the scope triggering controls adjusted to obtain a stable display. The PRF range switch and PRF control may then be adjusted to obtain the desired output PRF.
- 5) For operation below 100 MHz the frequency range should be in the LOW position while for operation above 100 MHz the switch should be in the HIGH position. However, position of this switch is not critical.
- 6) Clockwise rotation of the PW control increases the output duty cycle. Adjust for desired output pulse width (30 to 70% duty cycle).
- 7) The desired output amplitude is controlled primarily by the AMP control and partially by the TR-TF control. The TR-TF control also serves to sharpen the rise and fall times and to flatten the pulse top. Several iterative adjustments of the AMP and TR-TF controls may be necessary to simultaneously obtain the desired output amplitude while maintaining excellent pulse rise-fall times and flatness.
- 8) To trigger externally, set the INT-EXT switch to EXT and connect a sine wave generator to the TRIG connector. The output PRF will equal the sine wave PRF. The sine wave amplitude should be set at 0.3 VRMS.

- 9) To DC offset the output pulse connect a DC power supply set to required DC offset value to the back panel terminals marked O.S. The maximum attainable DC offset voltage is ± 50 Volts (for units without the OT or EO option only).
- 10) For units with the OT or EO options, the output DC offset is variable from +5 to -5 Volts by means of the front panel one turn OFFSET control. The offset control may be turned off by means of the rear panel ON-OFF OFFSET switch.
- 11) To voltage control the output offset, set the rear panel switch in the EXT position and apply 0 to +10V to connector A ($R_{IN} \geq 10K$). (EO option).
- 12) Dual Polarity Option (for units without the OT or EO options).

To invert the output of the AVNN unit, connect the AVX-2-T unit to the OUT port. An inverted pulse with a rise time < 100 ps is then obtained at the OUT port of the AVX-2-T unit. To offset the inverted pulse, apply the required DC level to the DC terminal of the AVX-2-T unit.

- 13) Dual Polarity Option (for units with the OT or EO options).

To invert the output of the AVNN unit, connect the AVX-2-T unit to the OUT port. An inverted pulse with a rise time < 100 ps is then obtained at the OUT port of the AVX-2-T unit. To offset the inverted pulse, connect a lead from the rear panel OS OUT banana plug to the DC terminal of the AVX-2-T unit. The DC offset at the output of the AVX-2-T unit is then controlled by the front panel OFFSET control.

- 14) The AVNN-C unit can be converted from 120 to 240V 50-60 Hz operation by adjusting the voltage selector card in the rear panel fused voltage selector-cable connector assembly.
- 15) For additional assistance:

Tel: (613) 226-5772
Fax: (613) 226-2802

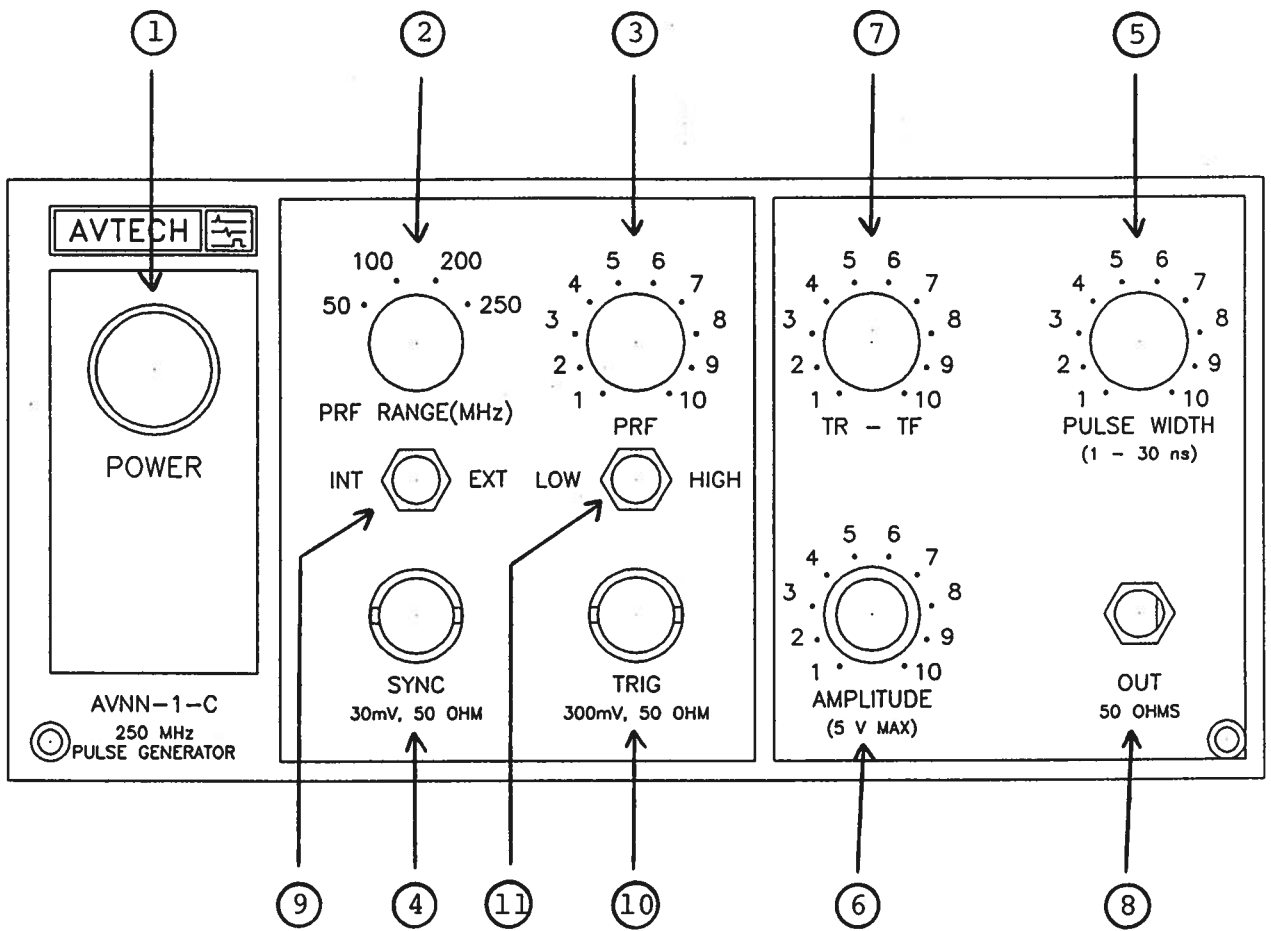

Fig. 2

FRONT PANEL CONTROLS

- (1) ON-OFF Switch. Applies basic prime power to all stages.
- (2) PRF Control. PRF RANGE and PRF controls determine
- (3) output PRF as follows:

	PRF MIN	PRF MAX
Range 1	25 MHz	75
Range 2	50	125
Range 3	100	200
Range 4	100	250

- (4) SYNC Output. This output is approximately coincident with the main output (8) and is used to trigger the sampling scope time base. The output is a 50 mV sine wave capable of driving a fifty Ohm load.
- (5) PW Control. One turn controls which vary the output pulse width (or duty cycle from about 30 to 70%).
- (6) AMP Control. A one turn control which varies the output pulse amplitude from 0 to max output to a fifty Ohm load.
- (7) TR-TF. Controls flatness of pulse top and rise and fall time. Turn counter clockwise to smooth top and to decrease rise, fall time.
- (8) OUT Connector. SMA connector provides output to a fifty Ohm load.
- (9) EXT-INT Control. With this toggle switch in the INT position, the PRF of the AVNN unit is controlled via an internal clock which in turn is controlled by the PRF RANGE and PRF controls. With the toggle switch in the EXT position, the AVNN unit requires a 0.3 V RMS sine wave applied at the TRIG input in order to trigger the output stages. In addition, in this mode, the scope time base must be triggered by the external trigger source.
- (10) TRIG Input. The external trigger signal is applied at this input when the EXT-INT toggle switch is in the EXT position.
- (11) FREQUENCY (LOW-HIGH). For operation below 100 MHz switch should be in the LOW position. For operation above 100 MHz switch should be in the HIGH position (in order to obtain fastest rise time and smoothest pulse shape).

Fig. 3

BACK PANEL CONTROLS (UNITS WITHOUT OT OR
EO OPTIONS)

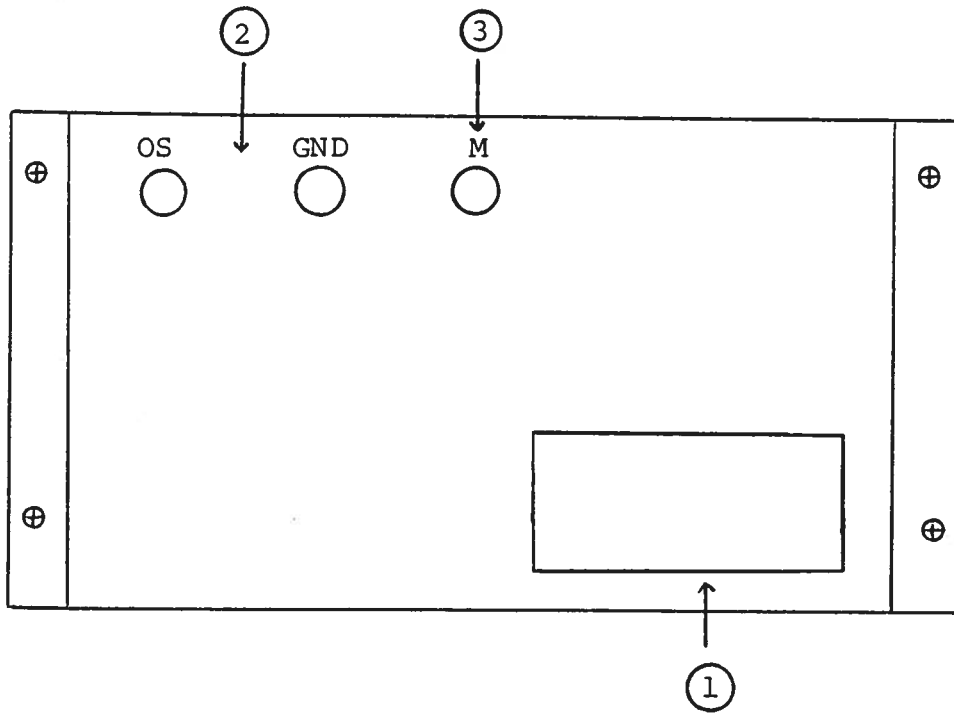

- (1) FUSED CONNECTOR, VOLTAGE SELECTOR. The detachable power cord is connected at this point. In addition, the removable cord is adjusted to select the desired input operating voltage. The unit also contains the main power fuse (0.5 Amp SB).
- (2) DC OFFSET Input. To DC offset the output pulse, connect a DC power supply set to the desired offset value to these terminals. The maximum allowable DC offset voltage is ± 50 Volts (maximum current is ± 250 mA).
- (3) MONITOR OUT M. Provides an attenuated (x10) coincident replica of the main positive output pulse to fifty Ohms (option).

Fig. 4

BACK PANEL CONTROLS (UNITS WITH OT OPTION)

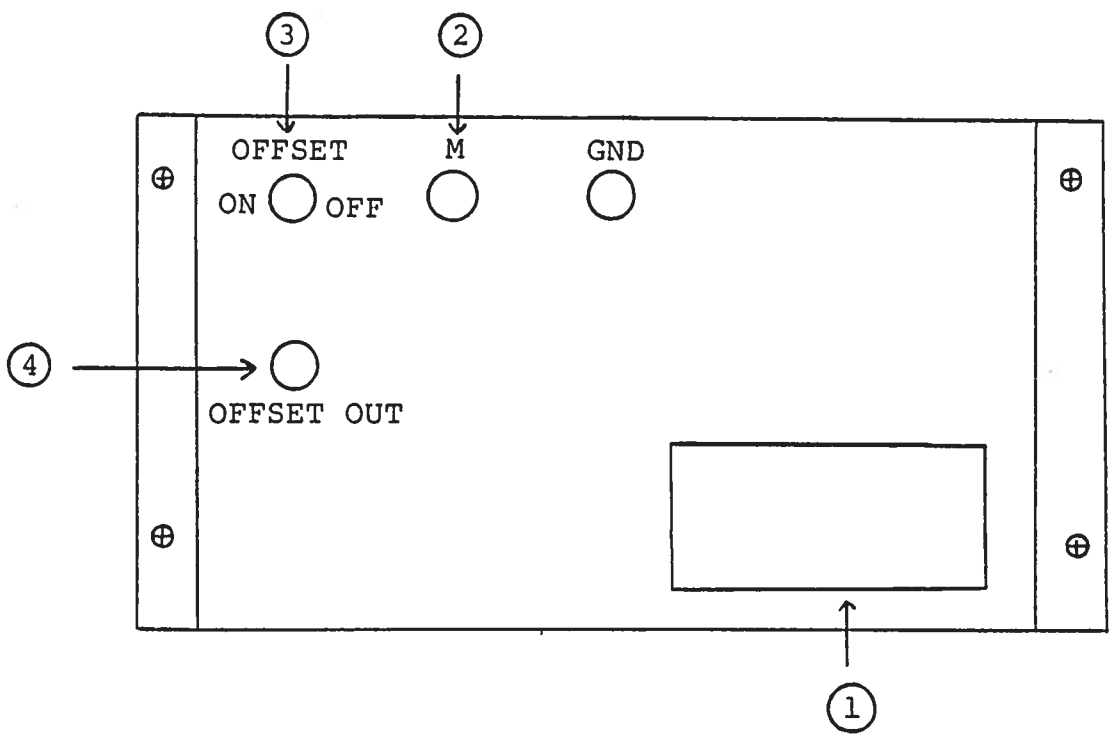

- (1) FUSED CONNECTOR, VOLTAGE SELECTOR. The detachable power cord is connected at this point. In addition, the removable cord is adjusted to select the desired input operating voltage. The unit also contains the main power fuse (0.5 Amp SB).
- (2) MONITOR OUT M. Provides an attenuated (x10) coincident replica of the main positive output pulse to fifty Ohms (option).
- (3) DC OFFSET. To turn DC output offset OFF put toggle switch in OFF position.
- (4) OFFSET OUT. To offset an inverted output pulse, connect a lead from the OFFSET OUT terminal to the DC terminal of the AVX-2-T unit. The DC offset at the output of the AVX-2-T unit is then controlled by the front panel OFFSET control.

Fig. 5

SYSTEM BLOCK DIAGRAM

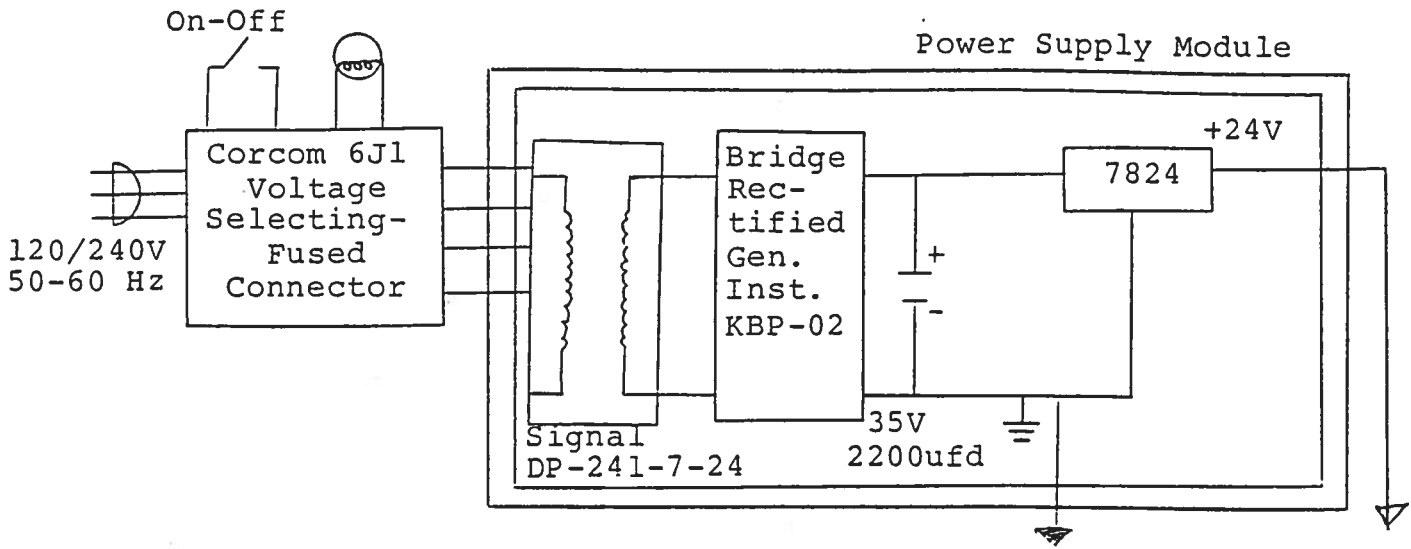

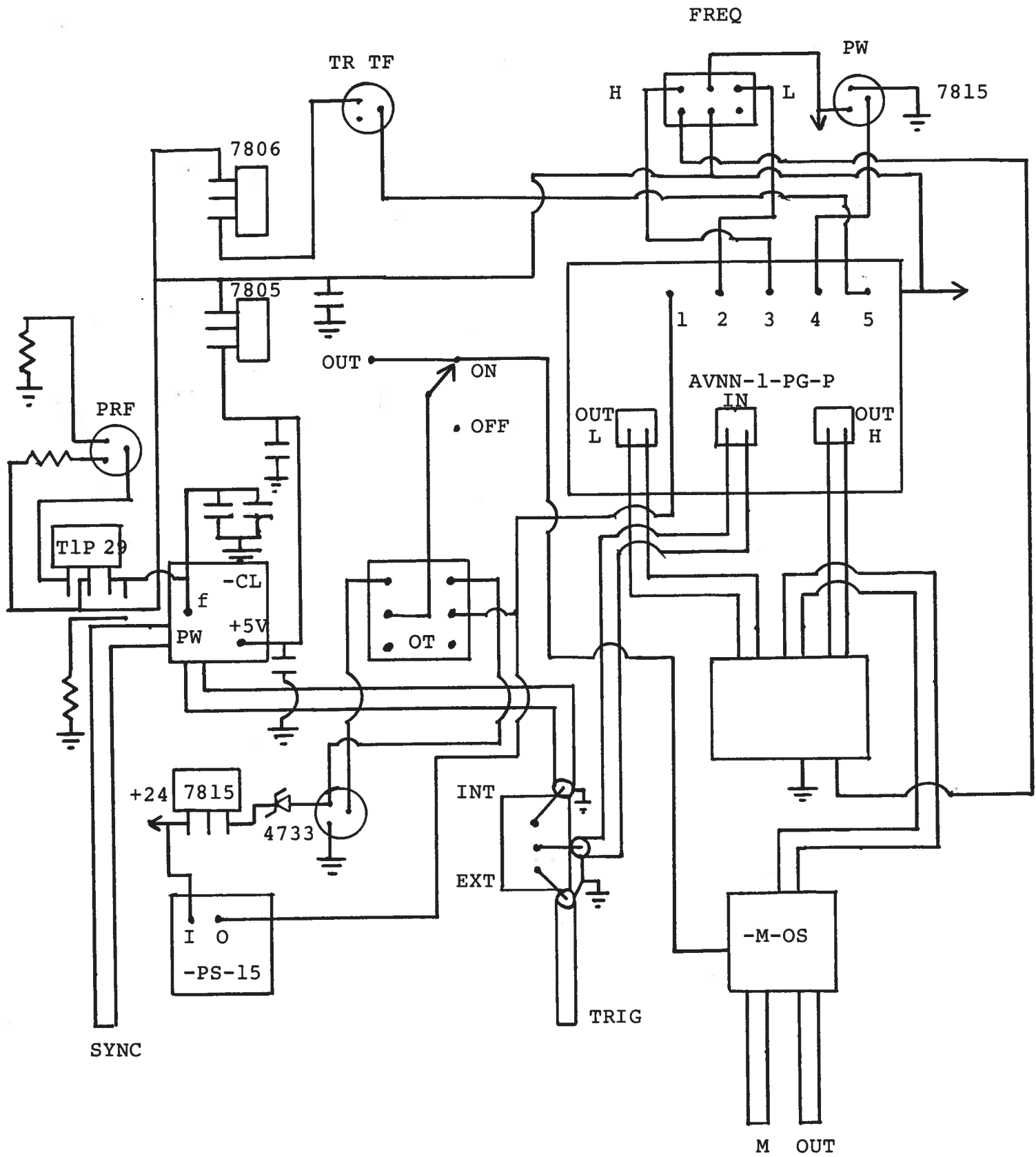

AVNN-1-C-M-OT BLOCK DIAGRAM

SYSTEM DESCRIPTION AND REPAIR PROCEDURE

The AVNN-C consists of a pulse generator module (AVNN-PG), a clock module (AVNN-CL), a -15V power supply module (-PS-1S), an offset module (-OT), a coaxial switch (RSM20) and a power supply board which supplies +24 Volts (800 mA max) to the pulse generator modules. In the event that the unit malfunctions, remove the instrument cover by removing the four Phillips screws on the back of the unit. The top may then be slid off. Measure the voltage at the +24V pin of the PG module. If this voltage is substantially less than +24 Volts, unsolder the line connecting the power supply and PG modules and connect 50 Ohm 10 W load to the PS output. The voltage across this load should be about +24 V DC. If this voltage is substantially less than 24 Volts the PS module is defective and should be repaired or replaced. If the voltage across the resistor is near 24 Volts, then the PG module should be replaced or repaired. The sealed PG module must be returned to Avtech for repair (or replacement). The clock module provides a 0.3 V RMS sine wave to trigger the PG module and a 30 mV sine wave to trigger the sampling scope display device. The clock module is powered by +5.0V supplied by the PG module. With the INT-EXT switch in the EXT position, the clock module is disconnected from the PG module.

The sealed clock module must be returned to Avtech for repair or replacement if the above conditions are not observed.

April 18/96

Edition B

11

-OT

Disk: AVN, AVNN

-EO

Name: AVNNCEDB.INS

-OS

-PN

-M