



AVTECH ELECTROSYSTEMS LTD.

NANOSECOND WAVEFORM ELECTRONICS
SINCE 1975

P.O. BOX 265
OGDENSBURG, NY
U.S.A. 13669-0265
TEL: (315) 472-5270
FAX: (613) 226-2802

TEL: 1-800-265-6681
FAX: 1-800-561-1970
U.S.A. & CANADA

e-mail: info@avtechpulse.com

BOX 5120 STN. F
OTTAWA, ONTARIO
CANADA K2C 3H4
TEL: (613) 226-5772
FAX: (613) 226-2802

INSTRUCTIONS

MODEL AVO-1 PULSE GENERATOR

S.N.:

WARRANTY

Avtech Electrosystems Ltd. warrants products of its manufacture to be free from defects in material and workmanship under conditions of normal use. If, within one year after delivery to the original owner, and after prepaid return by the original owner, this Avtech product is found to be defective, Avtech shall at its option repair or replace said defective item. This warranty does not apply to units which have been disassembled, modified or subjected to conditions exceeding the applicable specifications or ratings. This warranty is the extent of the obligation or liability assumed by Avtech with respect to this product and no other warranty or guarantee is either expressed or implied.

AVO TEST ARRANGEMENT

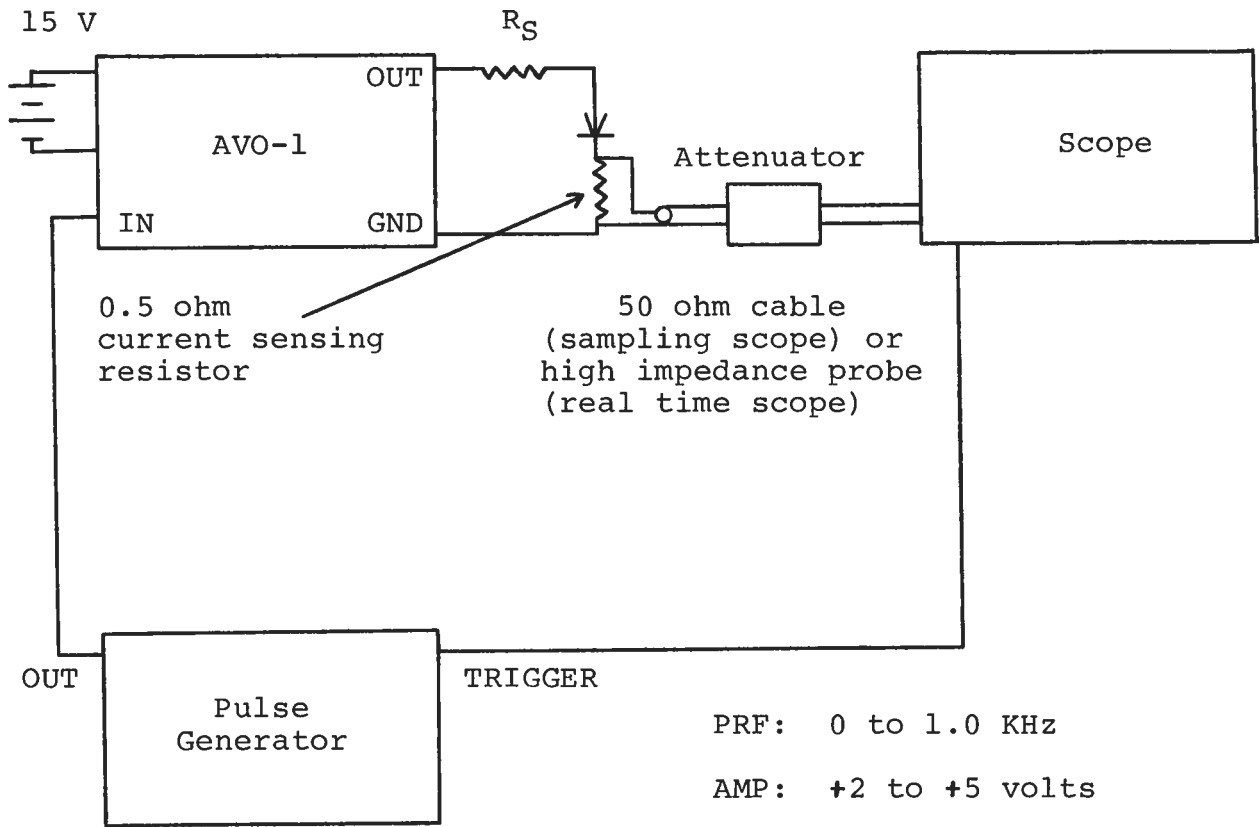

0.5 ohm
current sensing
resistor

50 ohm cable
(sampling scope) or
high impedance probe
(real time scope)

PRF: 0 to 1.0 KHz

AMP: +2 to +5 volts

PW: Approx. 0.5 usec

Notes:

- 1) The laser diode is connected in series with a current limiting resistor ($0.5 < R_E < 5$ ohm) between the GND and OUT terminals on the front panel. In order to monitor the diode current a 0.5 ohm current sensing resistor may be connected in series with the diode and resistor R_E . 1/4 watt carbon film or carbon composition resistors may be used but all leads must be as short as possible ($\ll 0.1$ inch). Solder leads directly to the GND and OUT terminals.
- 2) In general the pulse generator trigger delay control should be set in 0.1 to 1.0 usec range. Other settings should be as shown in the above diagram.
- 3) Either a sampling oscilloscope or a high speed real time oscilloscope (BW > 200 MHz) may be used to monitor the voltage across the current sensing resistor and therefore the laser diode current. If a sampling scope is used at least 40 db attenuation should be used to insure a scope input voltage of less than 1.0 volt.
- 4) The amplitude of the diode current is determined by the setting of the rear panel AMP pot control, the series resistor $R_E + 0.5$ ohm, and by the series resistance of the laser diode. The performance check results given in the following page were obtained using a 1N4736 diode to simulate a laser diode load. With this diode a peak current of 100 amperes was obtained with $R_E = 0.7$ ohm and the pot set maximum clockwise. A peak current of 20 amperes was obtained with $R_E 5.1$ and the pot set near maximum counterclockwise. The 1N4736 diode exhibited a peak forward voltage of about 30 volts at 100 amperes.
- 5) For different diode mountings the GND terminal may be unscrewed (4-40 thread) and replaced with other fixtures. Alternatively, ground fixtures may be machined on the flange protruding from the base of the chassis. Note: Do not attempt to remove or modify the OUT terminal.
- 6) WARNING: The unit may fail if triggered at a PRF exceeding 1 KHz.

Edition A