

**AVTECH ELECTROSYSTEMS LTD.**

**NANOSECOND WAVEFORM ELECTRONICS  
ENGINEERING . MANUFACTURING**

□ P.O. BOX 265  
OGDENSBURG  
NEW YORK  
13669  
(315) 472-5270

BOX 5120 STN. "F"  
OTTAWA, ONTARIO  
CANADA K2C 3H4  
(613) 226-5772  
TELEX 053-4591

**INSTRUCTIONS**

**MODEL AVO-2A PULSE GENERATOR**

**S.N. :**

### WARRANTY

Avtech Electrosystems Ltd. warrants products of its manufacture to be free from defects in material and workmanship under conditions of normal use. If, within one year after delivery to the original owner, and after prepaid return by the original owner, this Avtech product is found to be defective, Avtech shall at its option repair or replace said defective item. This warranty does not apply to units which have been disassembled, modified or subjected to conditions exceeding the applicable specifications or ratings. This warranty is the extent of the obligation or liability assumed by Avtech with respect to this product and no other warranty or guarantee is either expressed or implied.

AVO-2A TEST ARRANGEMENT

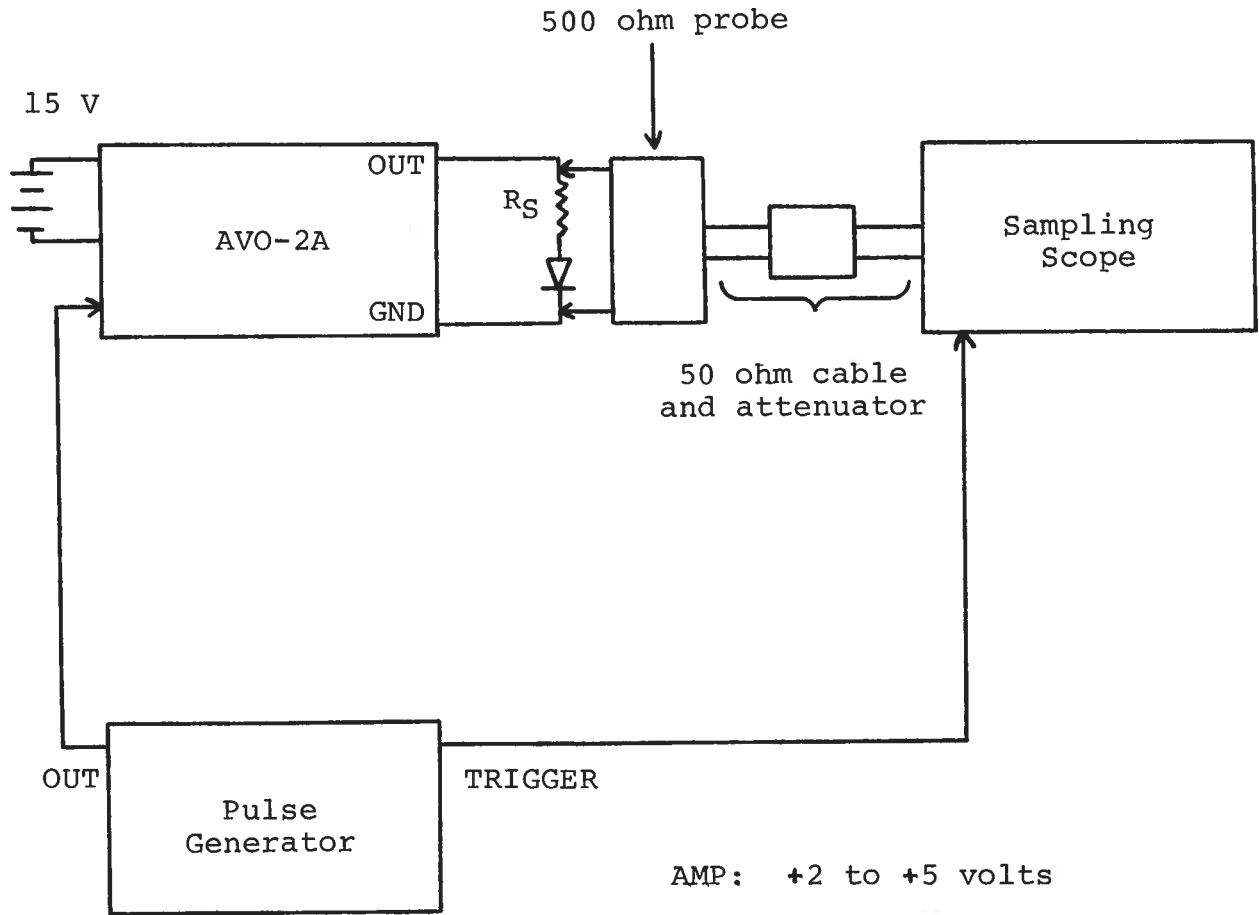

AMP: +2 to +5 volts

PRF: 0 to 20.0 KHz

PW: Approx. 0.5 usec

Notes:

- 1) The laser diode is connected in series with a current limiting resistor ( $8.0 < R_e < 10$  ohm) between the GND and OUT terminals on the front panel. 1/4 watt carbon film or carbon composition resistors may be used but all leads must be as short as possible ( $< 0.1$  inch). Solder leads directly to the GND and OUT terminals.
- 2) The amplitude of the diode current is determined primarily by the setting of the rear panel AMP pot control, and to a lesser extent by the limiting resistor  $R_e$  and by the series resistance of the laser diode. The performance check results given in the following page were obtained using a 1N4736 diode to simulate a laser diode load. With this diode a peak current of 5 amperes was obtained with  $R_e = 10$  ohm and the pot set maximum clockwise.
- 3) Either a sampling oscilloscope or a high speed real time oscilloscope ( $BW > 1000$  MHz) may be used to monitor the voltage across the current limiting resistor and therefore the laser diode current. If a sampling scope is used at least 40 db attenuation should be used to insure a scope input voltage of less than 1.0 volt since the peak pulse voltage between the OUT and GND terminals may be as high as 75 volts.
- 4) The output pulse width is controlled by means of the rear panel PW pot control. The pot should be set mid-range initially and the desired pulse width set using a scope. The waveform will degenerate to an impulse and eventually vanish as the pot is turned fully counter-clockwise.
- 5) In general the pulse generator trigger delay control should be set in 0.1 to 1.0 usec range. Other settings should be as shown in the above diagram.
- 6) WARNING: The unit may fail if triggered at a PRF exceeding 20 KHz.
- 7) For different diode mountings the GND terminal may be unscrewed (4-40 thread) and replaced with other fixtures. Alternatively, ground fixtures may be machined on the flange protruding from the base of the chassis. Note: Do not attempt to remove or modify the OUT terminal.
- 8) CAUTION: Use moderate heat when soldering to the OUT terminal.

ALTERNATE AVO-2A TEST ARRANGEMENT

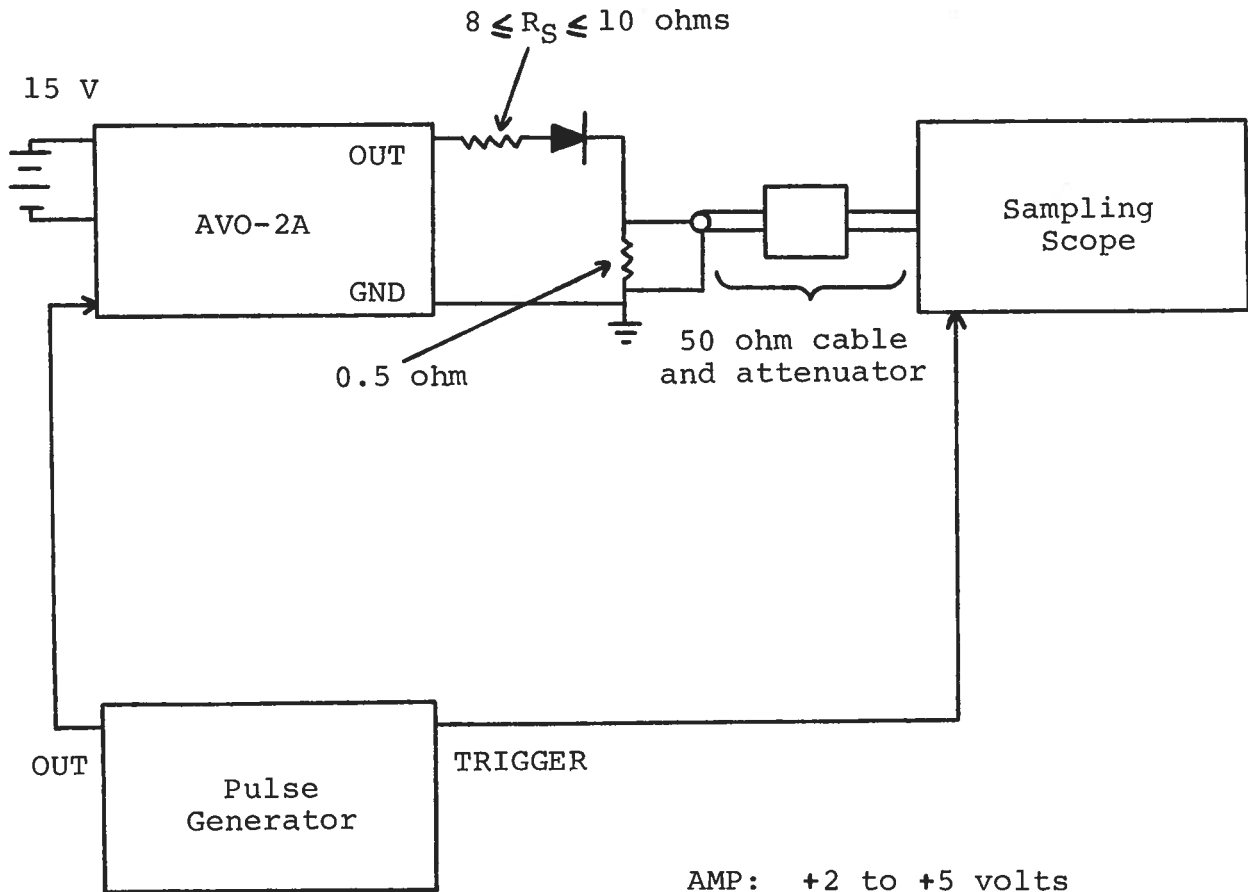

AMP: +2 to +5 volts  
PRF: 0 to 20.0 KHz  
PW: Approx. 0.5 usec