

AVTECH ELECTROSYSTEMS LTD.

NANOSECOND WAVEFORM ELECTRONICS
ENGINEERING - MANUFACTURING

□ P.O. BOX 265
OGDENSBURG
NEW YORK
13669
(315) 472-5270

BOX 5120, STN. "F"
OTTAWA, ONTARIO
CANADA K2C 3H4
TEL: (613) 226-5772
FAX: (613) 226-2802
TELEX: 053-4591

INSTRUCTIONS

MODEL AVO-2A-P-FOICA PULSE GENERATOR

S.N. :

WARRANTY

Avtech Electrosystems Ltd. warrants products of its manufacture to be free from defects in material and workmanship under conditions of normal use. If, within one year after delivery to the original owner, and after prepaid return by the original owner, this Avtech product is found to be defective, Avtech shall at its option repair or replace said defective item. This warranty does not apply to units which have been disassembled, modified or subjected to conditions exceeding the applicable specifications or ratings. This warranty is the extent of the obligation or liability assumed by Avtech with respect to this product and no other warranty or guarantee is either expressed or implied.

AVO-2A TEST ARRANGEMENT

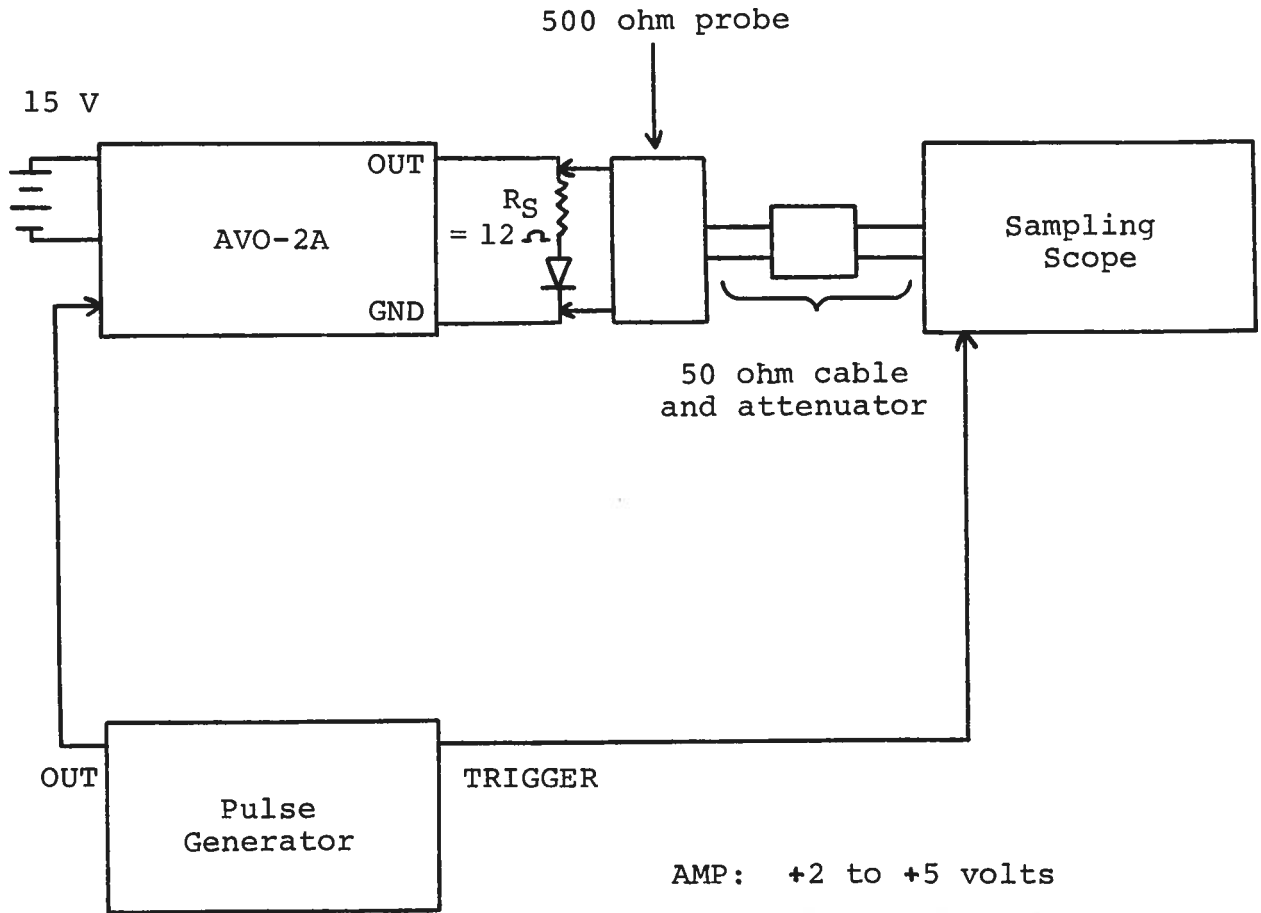

AMP: +2 to +5 volts
PRF: 0 to 50 KHz
PW: \geq 50 ns 0.5 usec

Notes:

- 1) The laser diode is connected in series with a current limiting resistor ($10 < R_s < 12 \text{ ohm}$) between the GND and OUT terminals on the front panel. 1/4 watt carbon film or carbon composition resistors may be used but all leads must be as short as possible ($< 0.1 \text{ inch}$). Solder leads directly to the output microstrip line as shown below:

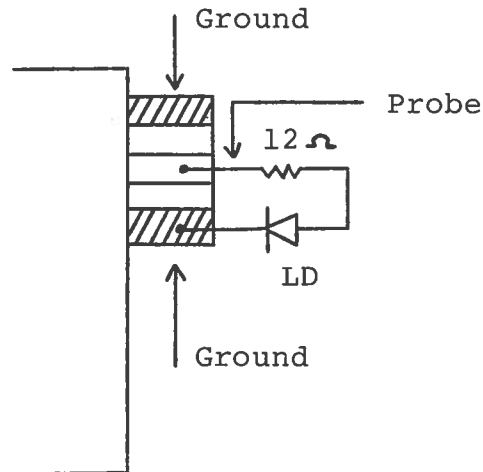

- 2) **CAUTION:** Use moderate heat when soldering to the OUT terminal.
- 3) The amplitude of the diode current is determined primarily by the setting of the rear panel AMP pot control.
- 4) Either a sampling oscilloscope or a high speed real time oscilloscope ($BW > 1000 \text{ MHz}$) may be used to monitor the voltage across the current limiting resistor and therefore the laser diode current. If a sampling scope is used at least 40 db attenuation should be used to insure a scope input voltage of less than 1.0 volt.
- 5) The output pulse width is controlled by means of the PW pot control. The pot should be set mid-range initially and the desired pulse width set using a scope. The waveform will degenerate to an impulse and eventually vanish as the pot is turned fully counter-clockwise.
- 6) In general the pulse generator trigger delay control should be set in 0.1 to 1.0 usec range. Other settings should be as shown in the above diagram.
- 7) **WARNING:** The unit may fail if triggered at a PRF exceeding 50 KHz.

12.05.90

1

1. The first part of the document is a list of names and addresses of the members of the committee. The names are listed in alphabetical order. The addresses are listed in the same order as the names. The list is as follows:

2. The second part of the document is a list of the names and addresses of the members of the committee who have been elected to the committee. The names are listed in alphabetical order. The addresses are listed in the same order as the names. The list is as follows:

3. The third part of the document is a list of the names and addresses of the members of the committee who have been elected to the committee. The names are listed in alphabetical order. The addresses are listed in the same order as the names. The list is as follows:

4. The fourth part of the document is a list of the names and addresses of the members of the committee who have been elected to the committee. The names are listed in alphabetical order. The addresses are listed in the same order as the names. The list is as follows: