

AVTECH ELECTROSYSTEMS LTD.

NANOSECOND WAVEFORM ELECTRONICS
ENGINEERING - MANUFACTURING

□ P.O. BOX 265
OGDENSBURG
NEW YORK
13669
(315) 472-5270

☒ BOX 5120, STN. "F"
OTTAWA, ONTARIO
CANADA K2C 3H4
TEL: (613) 226-5772
FAX: (613) 226-2802
TELEX: 053-4591

INSTRUCTIONS

MODEL AVO-2-PS-SUNY1 PULSE GENERATOR

S.N.:

WARRANTY

Avtech Electrosystems Ltd. warrants products of its manufacture to be free from defects in material and workmanship under conditions of normal use. If, within one year after delivery to the original owner, and after prepaid return by the original owner, this Avtech product is found to be defective, Avtech shall at its option repair or replace said defective item. This warranty does not apply to units which have been disassembled, modified or subjected to conditions exceeding the applicable specifications or ratings. This warranty is the extent of the obligation or liability assumed by Avtech with respect to this product and no other warranty or guarantee is either expressed or implied.

Fig. 1

PULSE GENERATOR TEST ARRANGEMENT

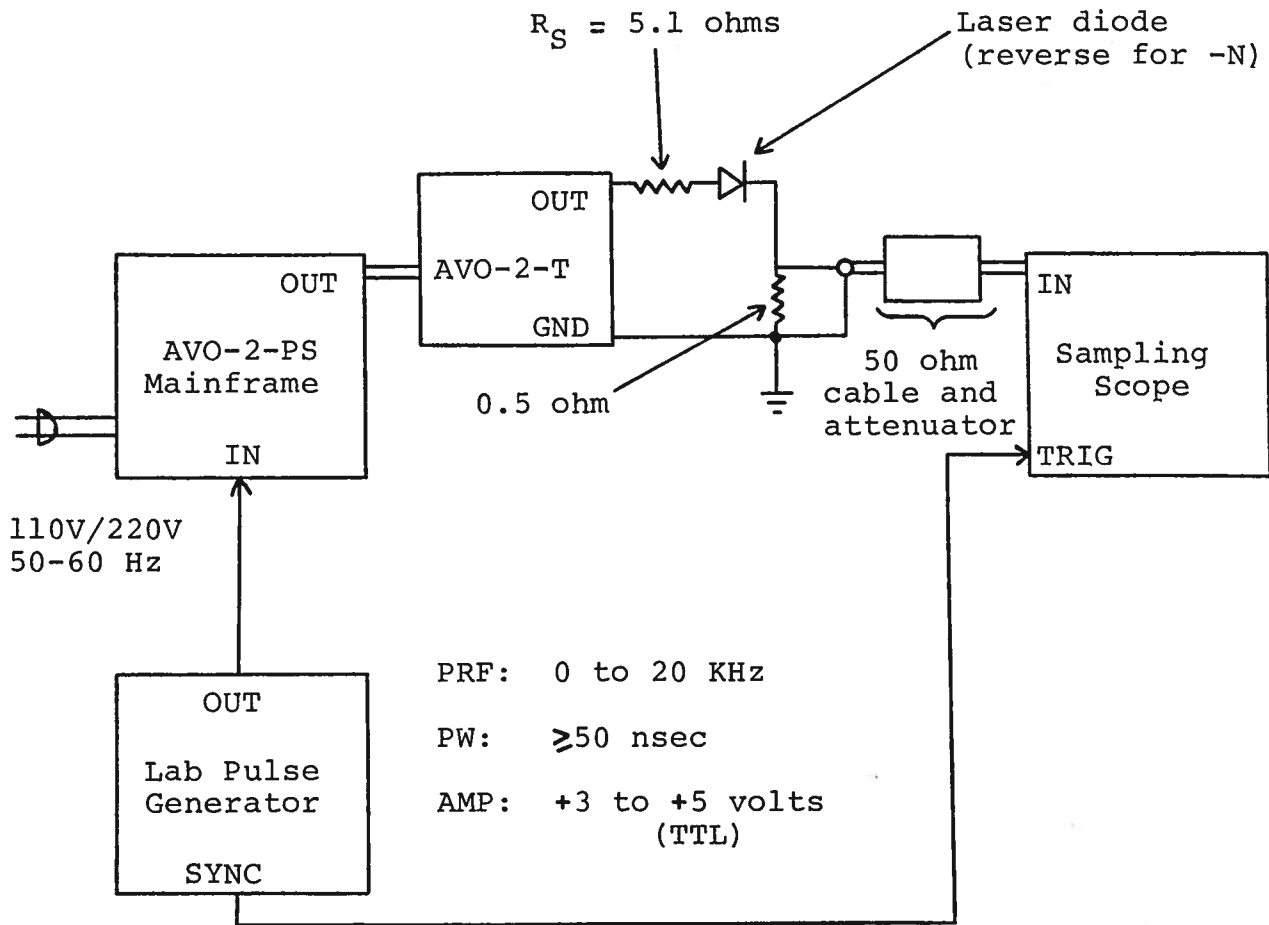

Notes:

- 1) The equipment should be connected in the general fashion shown above. Since the AVO unit provides an output pulse rise time as low as 1 nsec a fast oscilloscope (preferably 200 MHz) should be used to display the waveform. If a sampling scope is used, a 30 db (or greater) attenuator should be used to insure a peak input to the scope of less than 0.5 volts.
- 2) The output pulse width is controlled by means of the front panel one turn PW control. The control should initially be set maximum clockwise and the pulse width adjusted using an oscilloscope.
- 3) The output pulse amplitude is controlled by means of the front panel one turn AMP control.
- 4) The AVO-2-T module connects to the AVO mainframe via 2 parallel 9' RG58 coaxial cables. The cables may be shortened if required but at all times the 2 cables must be of equal length. The AVO-2-T module transforms the AVO mainframe output to 60 volts to 5.1 ohm. The laser diode is connected in series with a current limiting resistor ($R_B = 5.1$ ohm) between the GND and OUT terminals on the AVO-2-T. 1/4 watt carbon film or carbon composition resistors may be used but all leads must be as short as possible (< 0.1 inch). Solder leads directly to the GND and OUT terminals.
CAUTION: Use moderate heat when soldering to the OUT terminal.

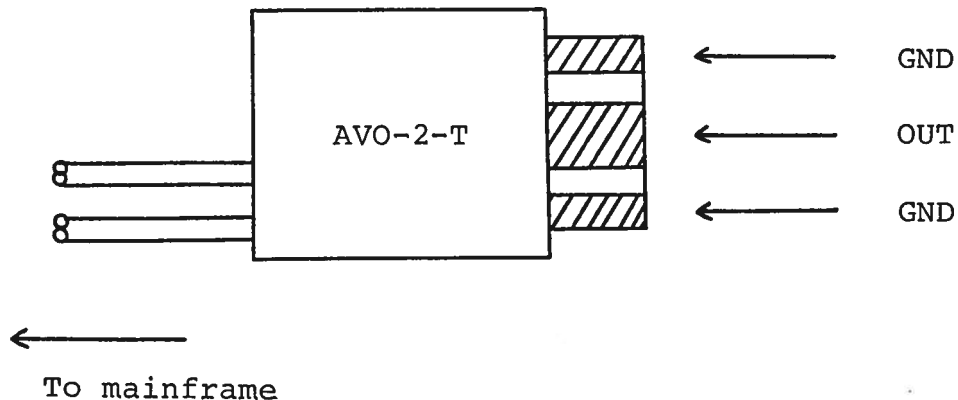

- 5) The amplitude of the diode current is determined primarily by the setting of the rear panel AMP pot control, and to a lesser extent by the limiting resistor R_e and by the series resistance of the laser diode. The performance check results given in the following page were obtained using a 1N4736 diode to simulate a laser diode load. With this diode a peak current of 10 amperes was obtained with $R_e = 5.1$ ohm and the pot set maximum clockwise.
- 6) Monitor output (option). The back panel monitor output port provides an output voltage to 50 ohms which is twice the amplitude appearing at the AVO-2-T output terminals. The diode load current can be computed as follows:

$$I_{DIODE} = \frac{0.5V_M - V_{DIODE}}{R_{SERIES}}$$

where $V_M = M$ output port voltage to 50 ohm

$V_{DIODE} =$ voltage across the laser diode

$R_{SERIES} =$ resistance placed in series between AVO-2-T output and laser diode

- 7) DC offset (option). The desired DC offset voltage (0 to +6 volts) is applied to the OS terminals on the AVO-2-T module. This voltage appears directly at the AVO-2-T output terminals and so with a diode series resistance of 5 ohms this will yield a maximum DC diode current of about 1.0 amperes.

Fig. 2

FRONT PANEL CONTROLS

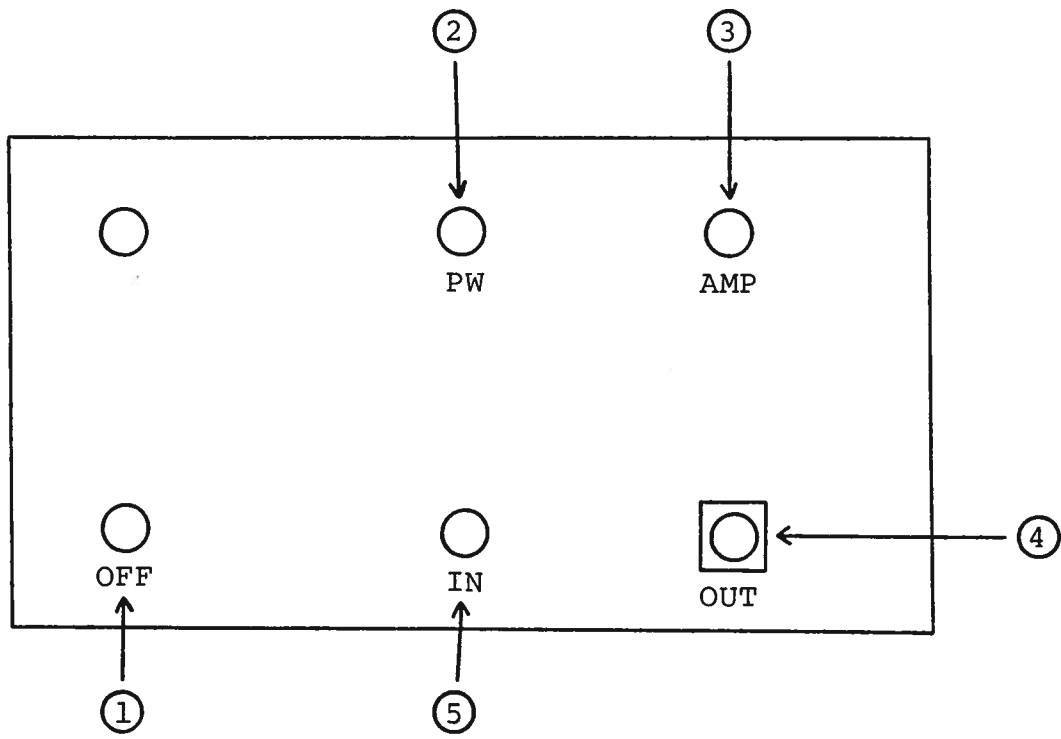

- (1) ON-OFF Switch. Applies basic prime power to all stages.
- (2) PW Control. A one turn control which varies the output pulse width from 0 to 50 nsec.
- (3) AMP Control. The output pulse amplitude is controlled by means of the one turn potentiometer (AMP).
- (4) OUT Connectors. Two SMA connectors for two miniature coaxial cables connected to the AVO-2-T module.
- (5) IN. The external trigger signal is applied at this input.

Fig. 3

BACK PANEL CONTROLS

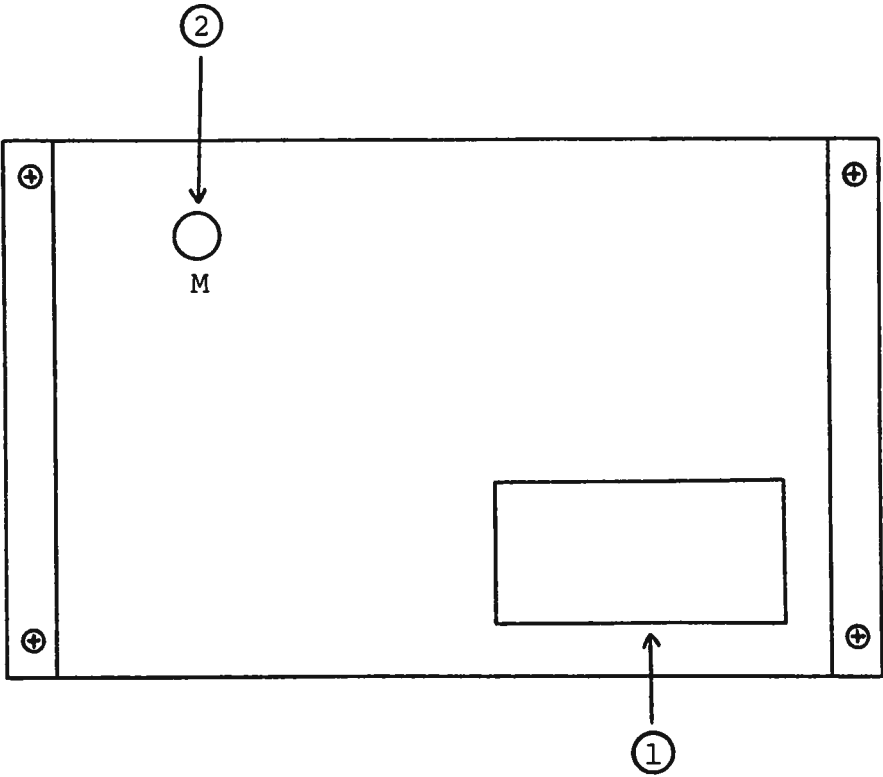

- (1) FUSED CONNECTOR, VOLTAGE SELECTOR. The detachable power cord is connected at this point. In addition, the removable cord is adjusted to select the desired input operating voltage. The unit also contains the main power fuse.
- (2) Monitor output (option). The back panel monitor output port provides an output voltage to 50 ohms which is twice the amplitude appearing at the AV0-2-T output terminals. The diode load current can be computed as follows:

$$I_{\text{DIODE}} = \frac{0.5V_M - V_{\text{DIODE}}}{R_{\text{SERIES}}}$$

where V_M = M output port voltage to 50 ohm

V_{DIODE} = voltage across the laser diode

R_{SERIES} = resistance placed in series between AV0-2-T output and laser diode

Fig. 4

SYSTEM BLOCK DIAGRAM

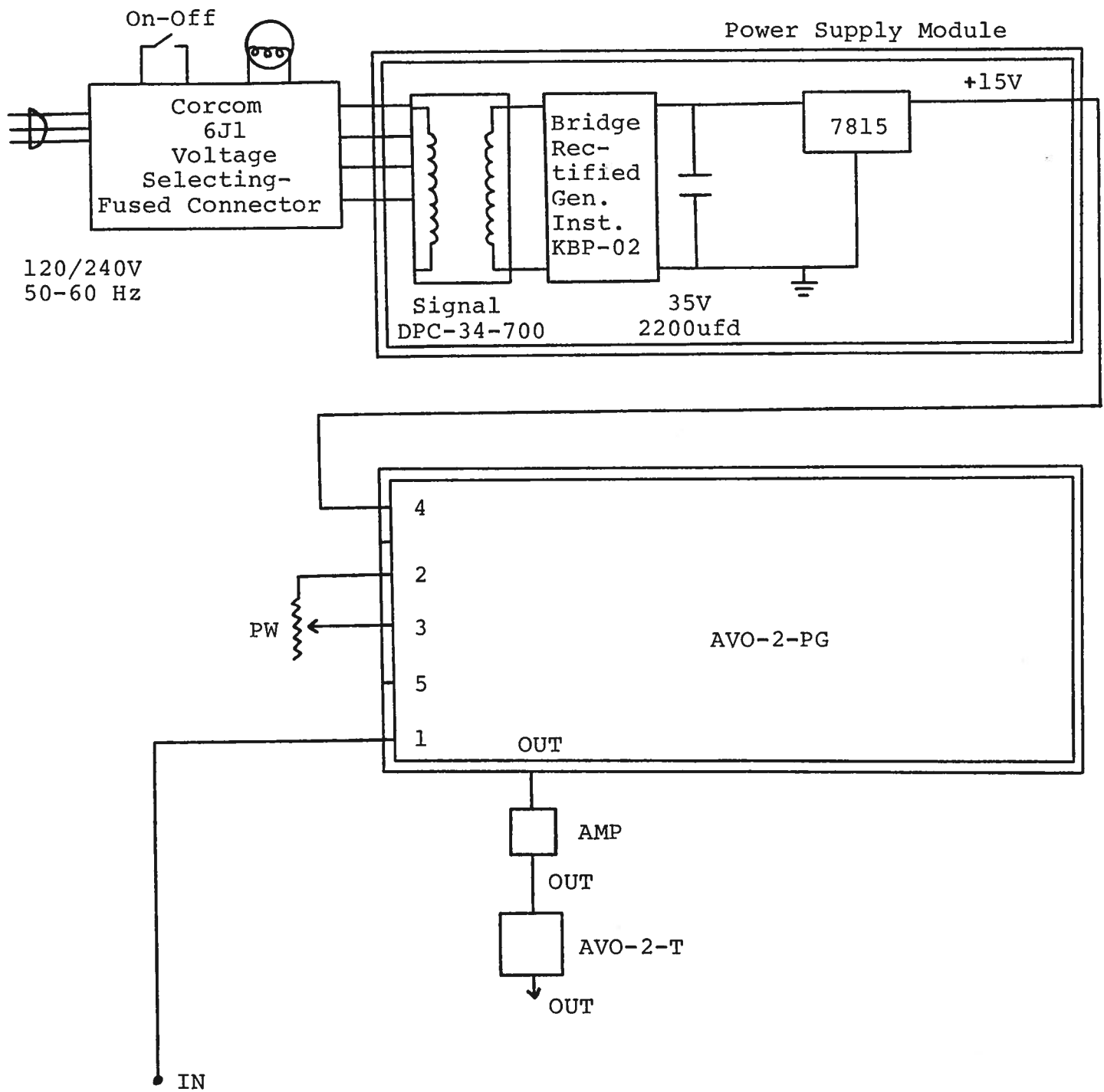

SYSTEM DESCRIPTION AND REPAIR PROCEDURE

The AVO-2-PS consists of a pulse generator module (AVO-2-PG) and a power supply board which supplies +15 volts (600 mA max) to the pulse generator module. In the event that the unit malfunctions, remove the instrument cover by removing the four Phillips screws on the back of the unit. The top cover may then be slid off. Measure the voltage at the +15V pin of the PG module. If this voltage is substantially less than +15 volts, unsolder the line connecting the power supply and PG modules and connect 50 ohm 10 W load to the PS output. The voltage across this load should be about +15 V DC. If this voltage is substantially less than 15 volts the PS module is defective and should be repaired or replaced. If the voltage across the resistor is near 15 volts, then the PG module should be replaced or repaired. The sealed PG module must be returned to Avtech for repair (or replacement).

Schroff

10.15.90

- M

- OS

- W