



AVTECH ELECTROSYSTEMS LTD.
NANOSECOND WAVEFORM ELECTRONICS

□ P.O. BOX 265
OGDENSBURG, NY
U.S.A. 13669-0265
TEL: (315) 472-5270
FAX: (613) 226-2802

✕ BOX 5120 STN. F
OTTAWA, ONTARIO
CANADA K2C 3H4
TEL: (613) 226-5772
FAX: (613) 226-2802

INSTRUCTIONS

MODEL AVO-2-C PULSE GENERATOR

S.N.:

WARRANTY

Avtech Electrosystems Ltd. warrants products of its manufacture to be free from defects in material and workmanship under conditions of normal use. If, within one year after delivery to the original owner, and after prepaid return by the original owner, this Avtech product is found to be defective, Avtech shall at its option repair or replace said defective item. This warranty does not apply to units which have been disassembled, modified or subjected to conditions exceeding the applicable specifications or ratings. This warranty is the extent of the obligation or liability assumed by Avtech with respect to this product and no other warranty or guarantee is either expressed or implied.

Fig. 1

PULSE GENERATOR TEST ARRANGEMENT

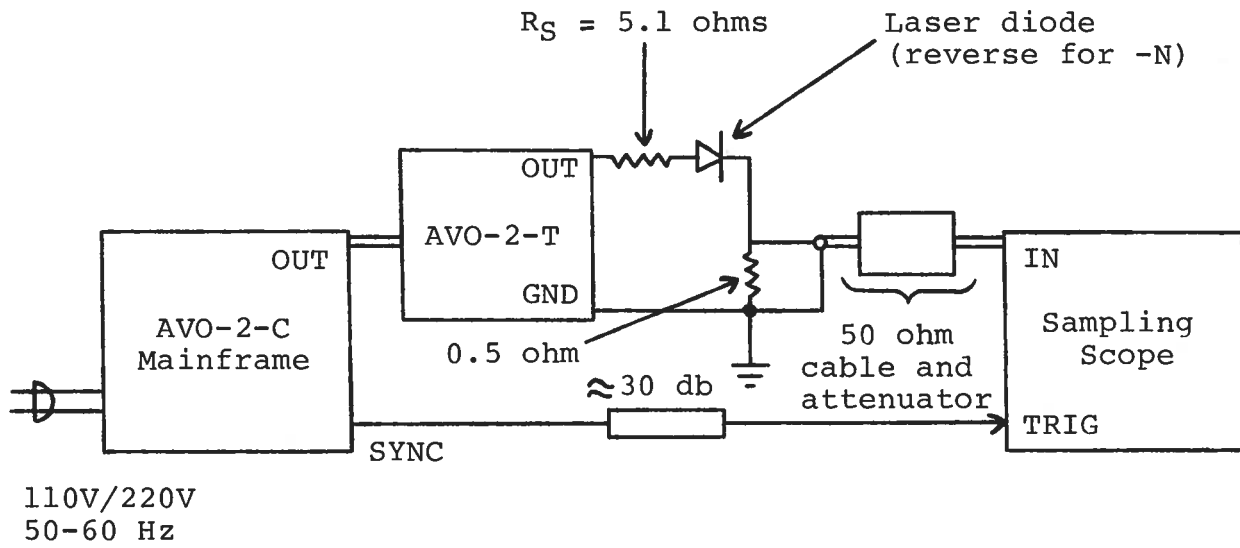

Notes:

- 1) The bandwidth capability of components and instruments used to display the pulse generator output signal (attenuators, cables, connectors, etc.) should exceed two gigahertz.
- 2) The use of 30 db attenuator at the sampling scope vertical input channel will insure a peak input signal to the sampling scope of less than one volt.
- 3) The sync output channel provides TTL level signals. To avoid overdriving the TRIG input channel of some sampling scopes, a 30 db attenuator should be placed at the input to the sampling scope trigger channel.
- 4) To obtain a stable output display the PRF control on the front panel should be set mid-range while the PRF switch may be in either range. The front panel TRIG toggle switch should be in the INT position. The front panel DELAY controls and the scope triggering controls are then adjusted to obtain a stable output. The scope may then be used to set the desired PRF by rotating the PRF control and by means of the back panel toggle switch.
- 5) The output pulse width is controlled by means of the front panel one turn PW control. The control should initially be set maximum clockwise and the pulse width adjusted using an oscilloscope.
- 6) The output pulse amplitude is controlled by means of the front panel one turn AMP control.
- 7) The AVO-2-T module connects to the AVO mainframe via a 2 foot long miniature coaxial cable. The AVO-2-T module transforms the AVO mainframe output to 60 volts to 5.1 ohm. The laser diode is connected in series with a current limiting resistor ($R_s = 5.1$ ohm) between the GND and OUT terminals on the AVO-2-T. 1/4 watt carbon film or carbon composition resistors may be used but all leads must be as short as possible (< 0.1 inch). Solder leads directly to the GND and OUT terminals.
CAUTION: Use moderate heat when soldering to the OUT terminal.

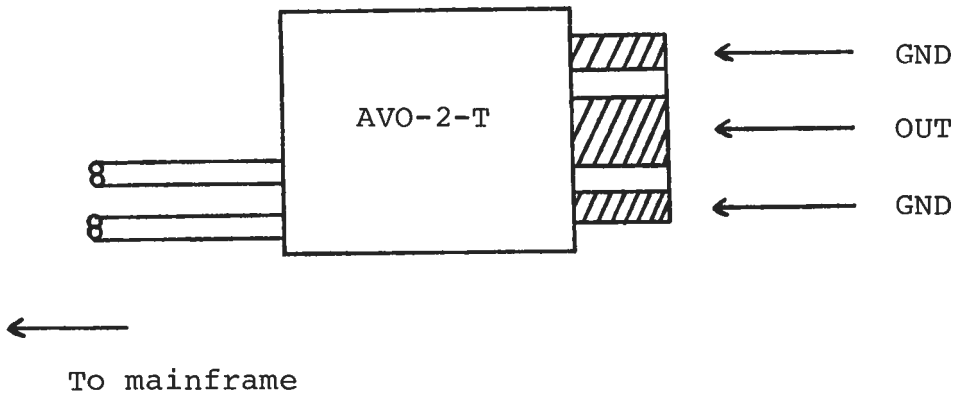

- 8) The amplitude of the diode current is determined primarily by the setting of the rear panel AMP pot control, and to a lesser extent by the limiting resistor R_s and by the series resistance of the laser diode. The performance check results given in the following page were obtained using a 1N4736 diode to simulate a laser diode load. With this diode a peak current of 10 amperes was obtained with $R_s = 5.1$ ohm and the pot set maximum clockwise.
- 9) An external clock may be used to control the output PRF of the AVO unit by setting the front panel TRIG toggle switch in the EXT position and applying a 0.2 usec (approx) TTL level pulse to the TRIG BNC connector input. For operation in this mode, the scope time base must also be triggered by the external clock rather than from the SYNC output.
- 10) Monitor output (option). The back panel monitor output port provides an output voltage to 50 ohms which is twice the amplitude appearing at the AVO-2-T output terminals. The diode load current can be computed as follows:

$$I_{DIODE} = \frac{0.5V_M - V_{DIODE}}{R_{SERIES}}$$

where $V_M = M$ output port voltage to 50 ohm

$V_{DIODE} =$ voltage across the laser diode

$R_{SERIES} =$ resistance placed in series between AVO-2-T output and laser diode

- 11) DC offset (option). The desired DC offset voltage (0 to ± 6 volts) is applied to the OS terminals on the AVO-2-T module. This voltage appears directly at the AVO-2-T output terminals and so with a diode series resistance of 5 ohms this will yield a maximum DC diode current of about 1.0 amperes.
- 12) DUAL POLARITY Option. The back panel two position polarity switch controls the polarity of the output pulse.

Fig. 2

FRONT PANEL CONTROLS

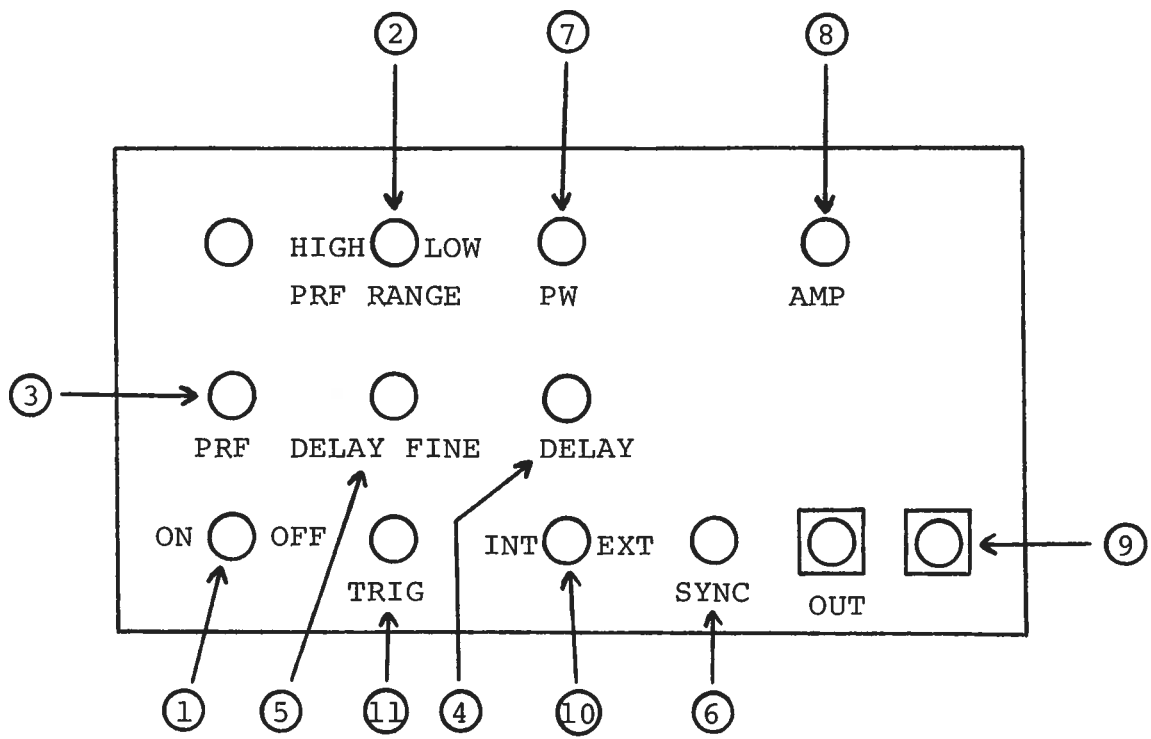

- (1) ON-OFF Switch. Applies basic prime power to all stages.
- (2) PRF Control. With PRF RANGE switch in the LOW position,
- (3) PRF control will vary PRF from 0.05 KHz to about 2.0 KHz. With PRF RANGE switch in the HIGH position, varies PRF from about 0.5 KHz to about 20 KHz.
- (4) DELAY Control. Controls the relative delay between the reference output pulse provided at the SYNC output (6) and the main output (9). This delay is variable over the range of 0 to at least 500 nsec.
- (5) DELAY FINE Control. As delay control but five times less sensitive.
- (6) SYNC Output. This output precedes the main output (9) and is used to trigger the sampling scope time base. The output is a TTL level 100 nsec (approx) pulse capable of driving a fifty ohm load.
- (7) PW Control. A one turn control which varies the output pulse width.
- (8) AMP Control. A one turn control which varies the output pulse amplitude.
- (9) OUT Connector. SMA connector provides output to AVO-2-T module.
- (10) EXT-INT Control. With this toggle switch in the INT position, the PRF of the AVO unit is controlled via an internal clock which in turn is controlled by the PRF controls. With the toggle switch in the EXT position, the AVO unit requires a 0.2 usec TTL level pulse applied at the TRIG input in order to trigger the output stages. In addition, in this mode, the scope time base must be triggered by the external trigger source.
- (11) TRIG Input. The external trigger signal is applied at this input when the EXT-INT toggle switch is in the EXT position.

Fig. 3

BACK PANEL CONTROLS

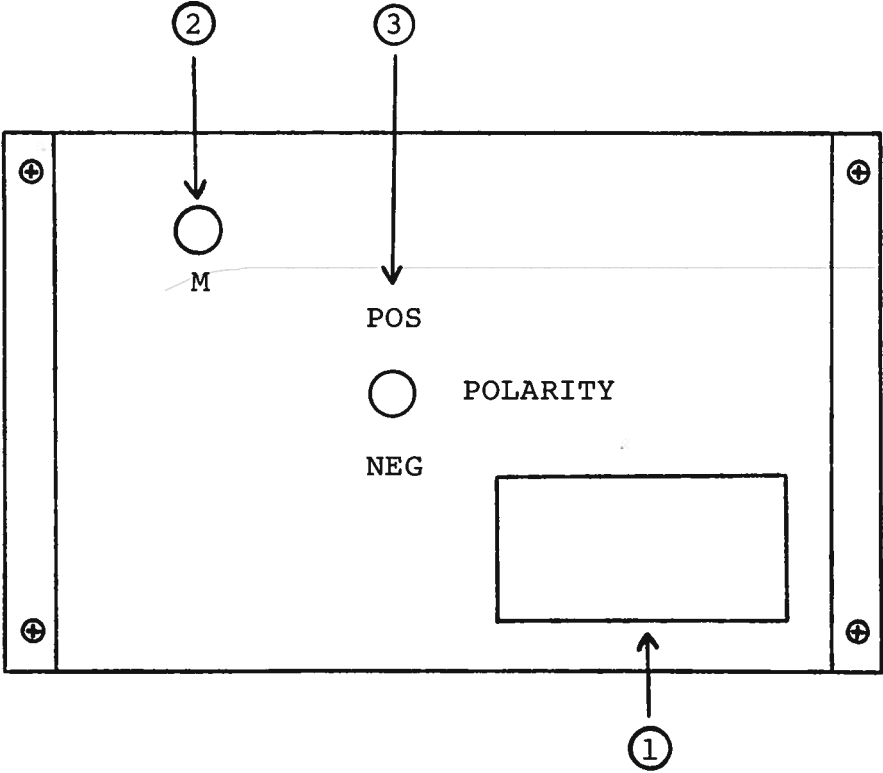

- (1) FUSED CONNECTOR, VOLTAGE SELECTOR. The detachable power cord is connected at this point. In addition, the removable cord is adjusted to select the desired input operating voltage. The unit also contains the main power fuse.
- (2) Monitor output (option). The back panel monitor output port provides an output voltage to 50 ohms which is twice the amplitude appearing at the AVD-2-T output terminals. The diode load current can be computed as follows:

$$I_{\text{DIODE}} = \frac{0.5V_M - V_{\text{DIODE}}}{R_{\text{SERIES}}}$$

where V_M = M output port voltage to 50 ohm

V_{DIODE} = voltage across the laser diode

R_{SERIES} = resistance placed in series between AVD-2-T output and laser diode

- (3) OUTPUT POLARITY (option). Two position switch controls the polarity of the output pulse.

Fig. 4

SYSTEM BLOCK DIAGRAM

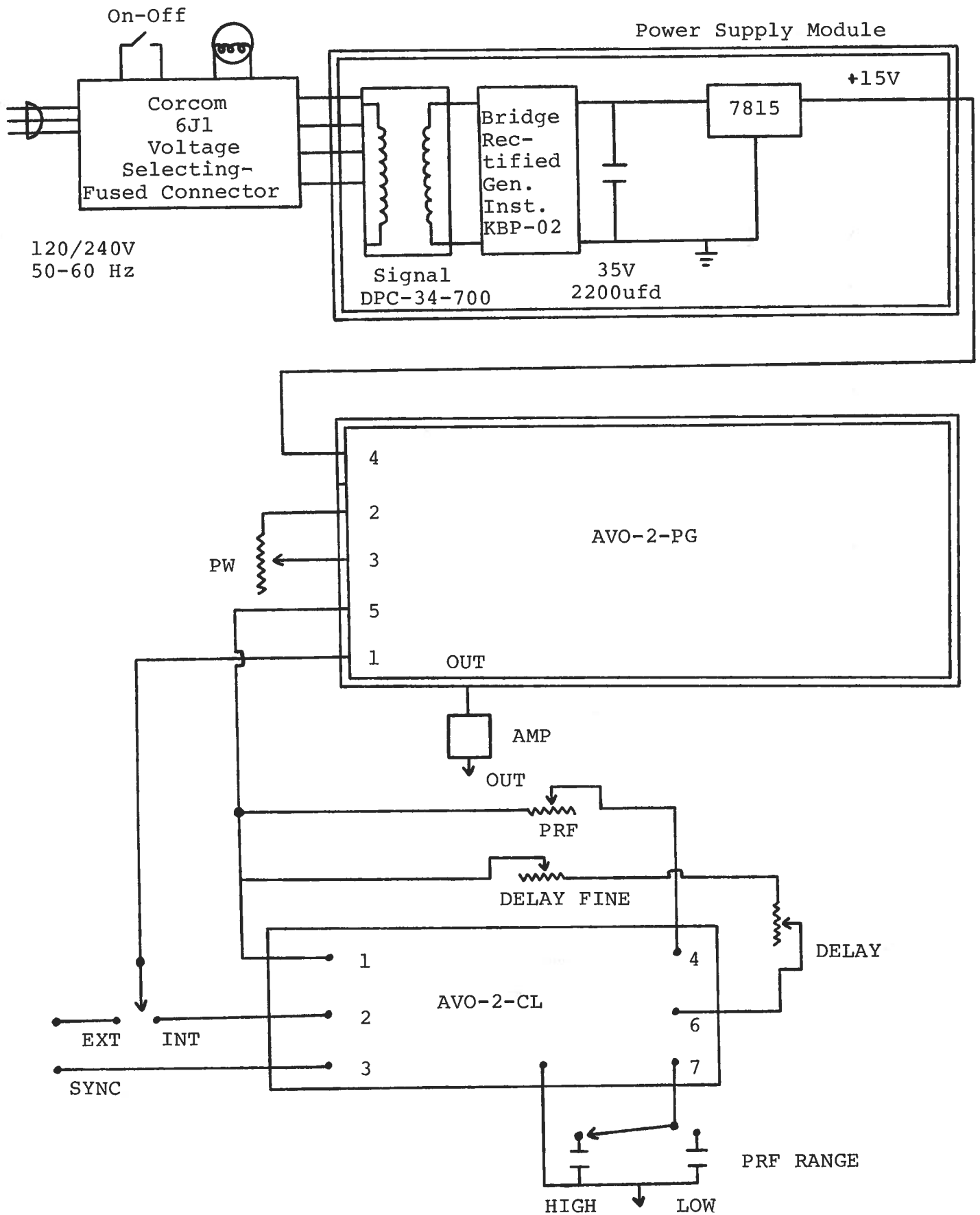

SYSTEM DESCRIPTION AND REPAIR PROCEDURE

The AVO-2-C consists of a pulse generator module (AVO-2-PG), a clock module (AVO-2-CL) and a power supply board which supplies +15 volts (600 mA max) to the pulse generator module. In the event that the unit malfunctions, remove the instrument cover by removing the four Phillips screws on the back of the unit. The top cover may then be slid off. Measure the voltage at the +15V pin of the PG module. If this voltage is substantially less than +15 volts, unsolder the line connecting the power supply and PG modules and connect 50 ohm 10 W load to the PS output. The voltage across this load should be about +15 V DC. If this voltage is substantially less than 15 volts the PS module is defective and should be repaired or replaced. If the voltage across the resistor is near 15 volts, then the PG module should be replaced or repaired. The sealed PG module must be returned to Avtech for repair (or replacement). The clock module provides a 0.1 usec TTL level trigger pulse at pin 2 to trigger the PG module and a 0.1 usec TTL level sync pulse at pin 3 to trigger the sampling scope display device. The output at pin 3 precedes the output at pin 2 by almost 0 to 500 nsec depending on the DELAY control setting. With the INT-EXT switch in the EXT position, the clock module is disconnected from the PG module. The clock module is functioning properly if:

- a) 0.1 usec TTL level outputs are observed at pins 2 and 3.
- b) The PRF of the outputs can be varied over the range of 0.05 KHz to 20 KHz using the PRF and PRF RANGE controls.
- c) The relative delay between the pin 2 and 3 outputs can be varied by at least 500 nsec by the DELAY control.

The sealed clock module must be returned to Avtech for repair or replacement if the above conditions are not observed.

Schroff

06.02.88 Edition A

-OS

-M

-W

-PN