



AVTECH ELECTROSYSTEMS LTD.

NANOSECOND WAVEFORM ELECTRONICS
SINCE 1975

P.O. BOX 265
OGDENSBURG, NY
U.S.A. 13669-0265
TEL: (315) 472-5270
FAX: (613) 226-2802

TEL: 1-800-265-6681
FAX: 1-800-561-1970
U.S.A. & CANADA

e-mail: info@avtechpulse.com

BOX 5120 STN. F
OTTAWA, ONTARIO
CANADA K2C 3H4
TEL: (613) 226-5772
FAX: (613) 226-2802

INSTRUCTIONS

MODEL AVO-3A-C PULSE GENERATOR

S.N.:

WARRANTY

Avtech Electrosystems Ltd. warrants products of its manufacture to be free from defects in material and workmanship under conditions of normal use. If, within one year after delivery to the original owner, and after prepaid return by the original owner, this Avtech product is found to be defective, Avtech shall at its option repair or replace said defective item. This warranty does not apply to units which have been disassembled, modified or subjected to conditions exceeding the applicable specifications or ratings. This warranty is the extent of the obligation or liability assumed by Avtech with respect to this product and no other warranty or guarantee is either expressed or implied.

Fig. 1

AVO-3 TEST ARRANGEMENT

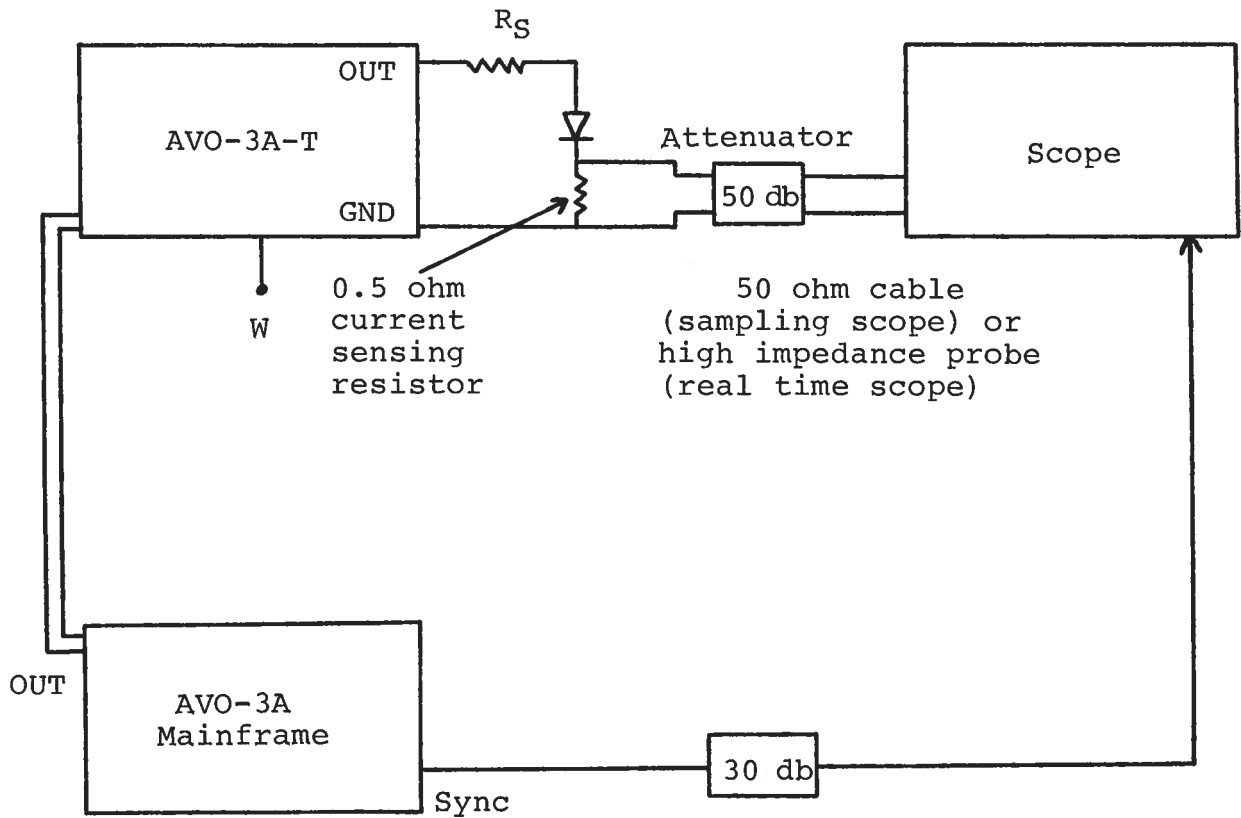

Notes:

- 1) The equipment should be connected in the general fashion shown above. Since the AVO unit provides an output pulse rise time as low as 1 nsec a fast oscilloscope (at least 1 GHz) should be used to display the waveform. If a sampling scope is used, a 50 db (or greater) attenuator should be used to insure a peak input to the scope of less than 0.5 volts.
- 2) The sync output channel provides TTL level signals. To avoid overdriving the TRIG input channel of some sampling scopes, a 30 db attenuator should be placed at the input to the sampling scope trigger channel.
- 3) To obtain a stable output display the PRF and PRF RANGE controls on the front panel should be set mid-range. The front panel TRIG toggle switch should be in the INT position. The front panel DELAY control and the scope triggering controls are then adjusted to obtain a stable output. The scope may then be used to set the desired PRF by using the PRF and PRF RANGE controls. The main output is delayed with respect to the SYNC output by about 0 to 200 nsec depending on the DELAY control setting.
- 4) The laser diode is connected in series with a current limiting resistor ($0.5 < R_B < 10$ ohm) between the GND and OUT terminals on the AVO-3A-T module. In order to monitor the diode current a 0.5 ohm current sensing resistor may be connected in series with the diode and resistor R_B . 1/4 watt carbon film or carbon composition resistors may be used but all leads must be as short as possible (≤ 0.1 inch). Solder leads directly to the GND and OUT terminals. An alternative current monitoring arrangement employing a high impedance probe is shown in Fig. 2. With either arrangement (Fig. 1 or Fig. 2), some ringing may be observed following the output impulse. This ringing is largely the consequence of the exceedingly low probe load impedance.
- 5) The amplitude of the diode current is determined by the setting of the AMP pot control, the series resistor $R_B + 0.5$ ohm, and by the series resistance of the laser diode. The performance check results given in the following page were obtained using a 1N4736 diode to simulate a laser diode load. With this diode a peak current of 20 amperes was obtained with $R_B = 5.1$ ohm and the pot set maximum clockwise. A peak current of 75 amperes was obtained with $R_B = 1.1$ ohm and the pot set near maximum clockwise.
- 6) WARNING: The unit may fail if triggered at a PRF exceeding 20 KHz. Use moderate heat when soldering to

the OUT terminal.

- 7) The AVO-3A-T module connects to the AVO-3A mainframe via a 2 foot long cable which is permanently attached to the AVO-3A-T module. Note that this cable should not be disconnected from the mainframe when the prime power is on as voltages as high as 400 volts are transmitted on the cable.
- 8) CAUTION: For units with the -W option, terminal -W of the AVO-3A-T module is at a DC potential as high as 400 volts when the prime power to the unit is turned on. Therefore, take care to insulate the terminal once the load has been connected.
- 9) -W option. The output pulse width of the AVO-3A-T unit can be increased from about 2 nsec to about 10 nsec by placing a capacitor between the -W and GND terminals. The capacitor should be soldered on using extremely short leads (< 0.1 cm). Silver mica capacitors with a voltage rating in excess of 400V are recommended. A 1000 pfd capacitance provides an output pulse width of about 10 nsec.

Fig. 2

AVO-3 TEST ARRANGEMENT

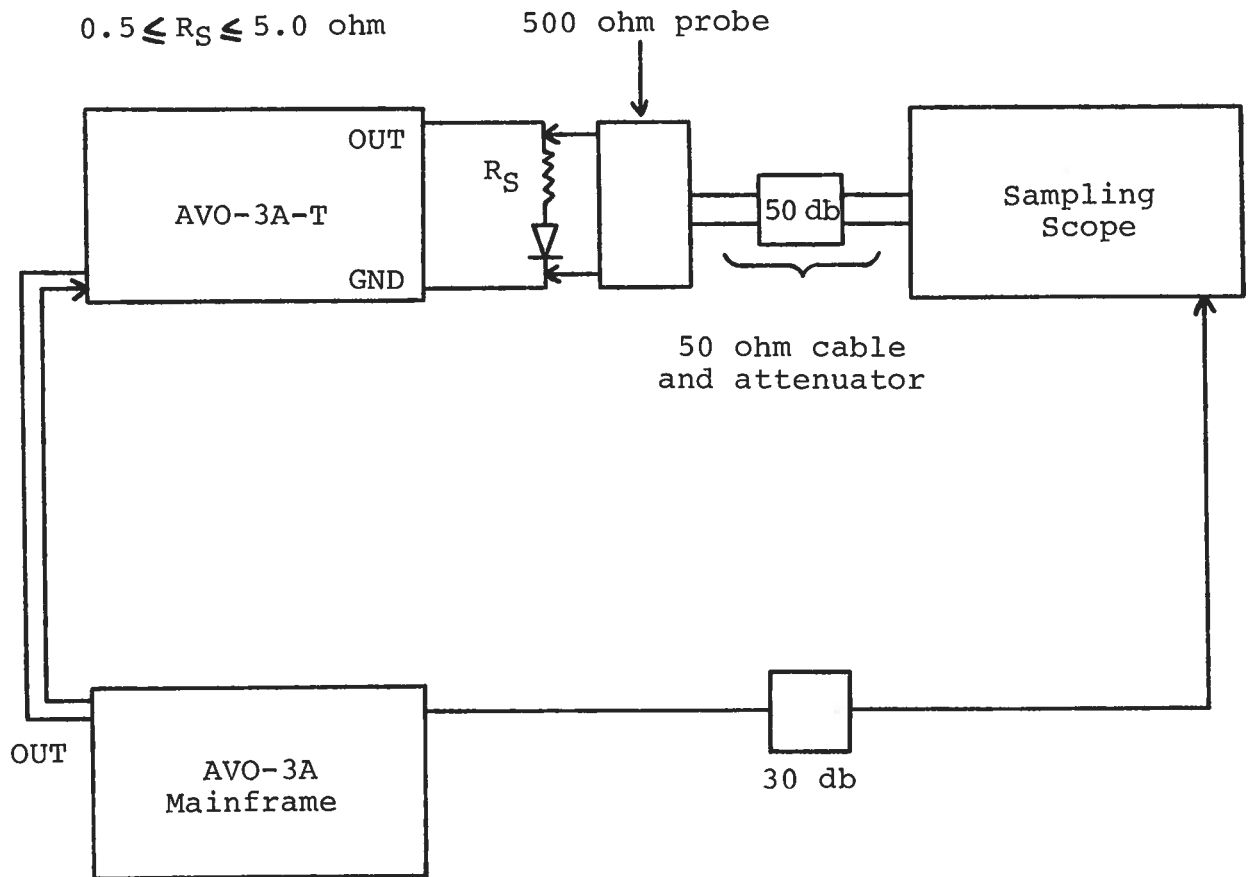
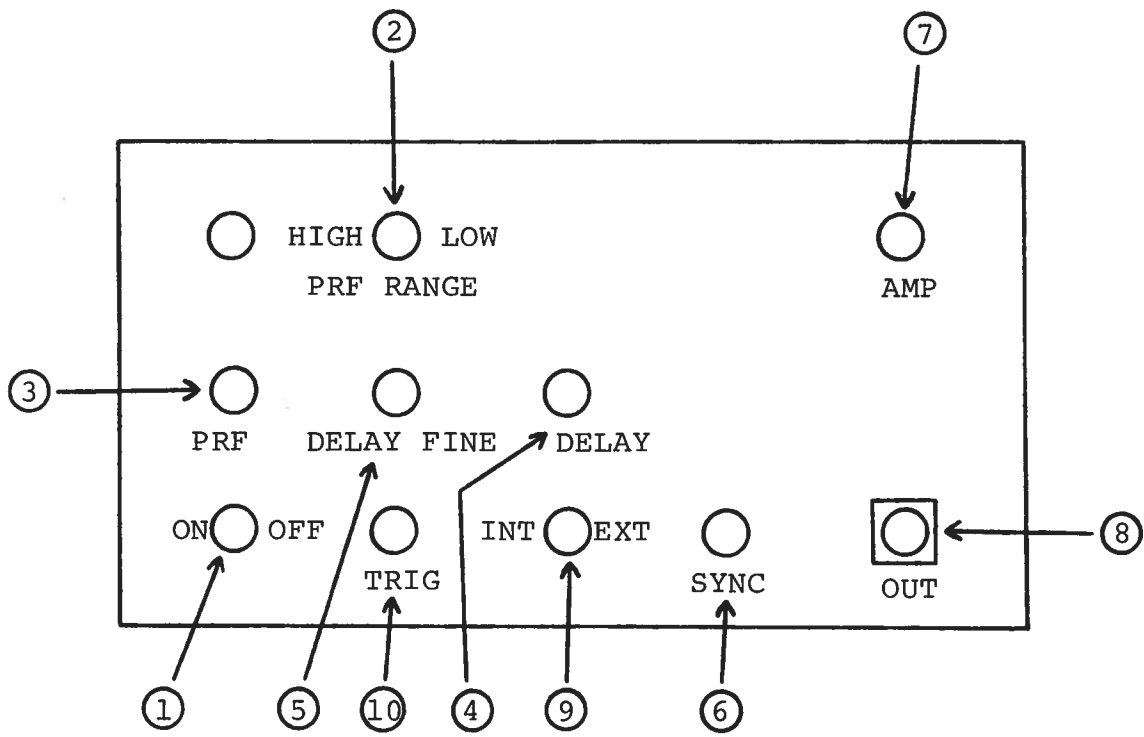

Fig. 3

FRONT PANEL CONTROLS



- (1) ON-OFF Switch. Applies basic prime power to all stages.
- (2) PRF Control. With PRF RANGE switch in the LOW position,
- (3) PRF control will vary PRF from 0.05 KHz to about 2.0 KHz. With PRF RANGE switch in the HIGH position, varies PRF from about 0.5 KHz to about 20 KHz.
- (4) DELAY Control. Controls the relative delay between the reference output pulse provided at the SYNC output (6) and the main output (8). This delay is variable over the range of 0 to at least 500 nsec.
- (5) DELAY FINE Control. As delay control but five times less sensitive.
- (6) SYNC Output. This output precedes the main output (8) and is used to trigger the sampling scope time base. The output is a TTL level 100 nsec (approx) pulse capable of driving a fifty ohm load.
- (7) AMP Control. A one turn control which varies the output pulse amplitude in combination with the diode series resistor.
- (8) OUT Connector. Multiwire cable from AVO-3A-T connects to mainframe at this point.
- (9) EXT-INT Control. With this toggle switch in the INT position, the PRF of the AVO unit is controlled via an internal clock which in turn is controlled by the PRF control. With the toggle switch in the EXT position, the AVO unit requires a 0.2 usec TTL level pulse applied at the TRIG input in order to trigger the output stages. In addition, in this mode, the scope time base must be triggered by the external trigger source.
- (10) TRIG Input. The external trigger signal is applied at this input when the EXT-INT toggle switch is in the EXT position.

Fig. 4

BACK PANEL CONTROLS

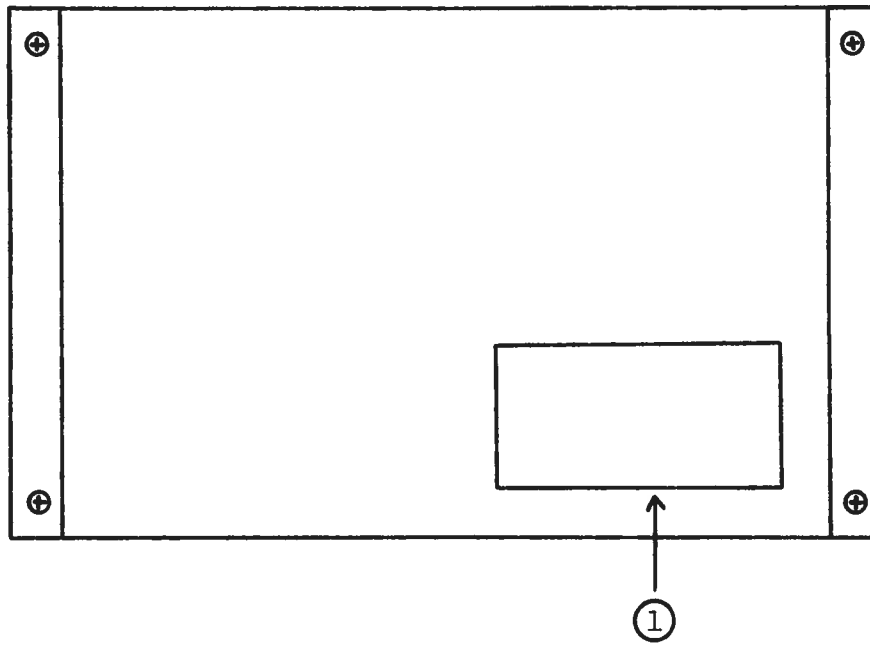

- (1) FUSED CONNECTOR, VOLTAGE SELECTOR. The detachable power cord is connected at this point. In addition, the removable cord is adjusted to select the desired input operating voltage. The unit also contains the main power fuse.

Fig. 5

SYSTEM BLOCK DIAGRAM

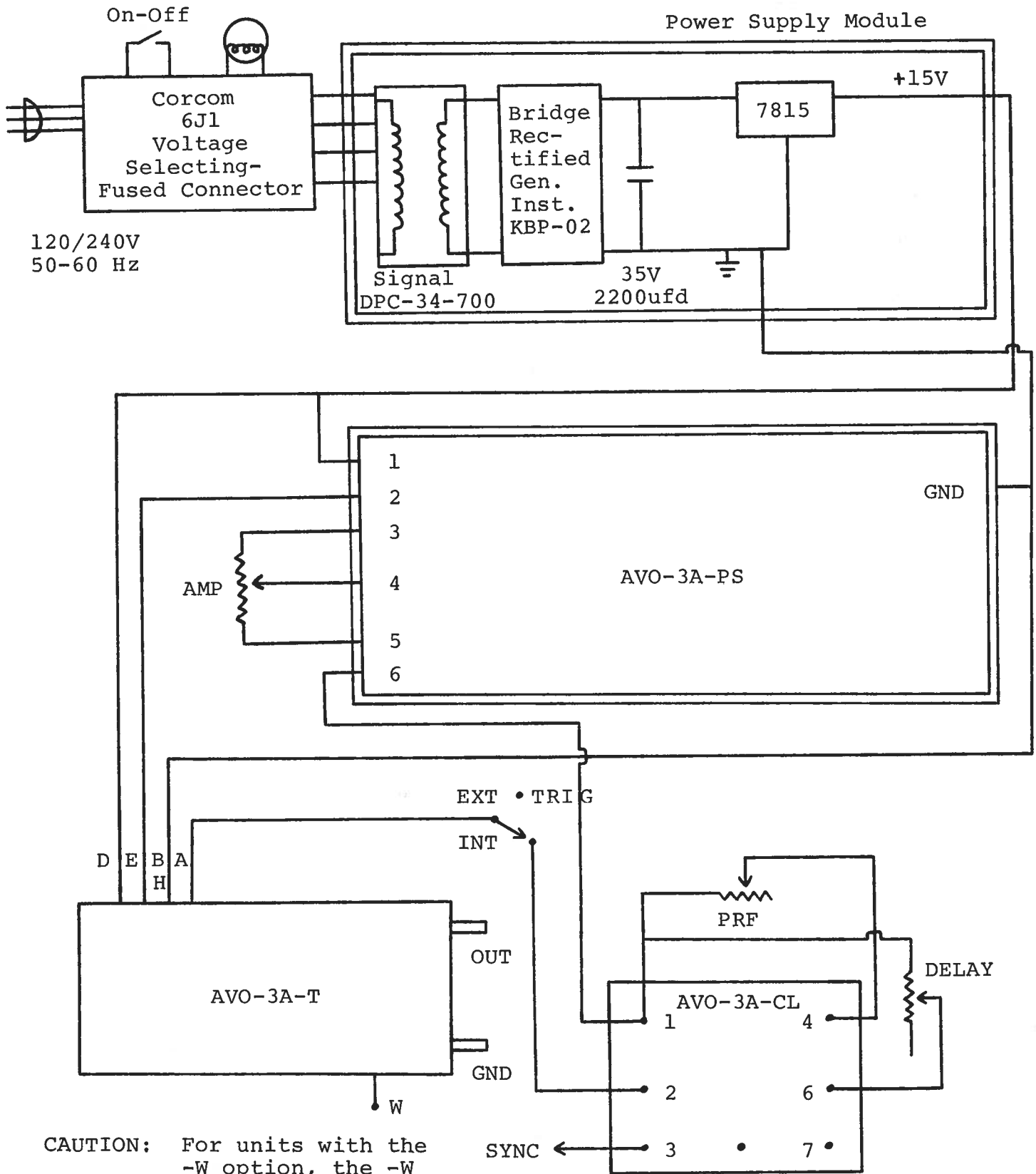

CAUTION: For units with the -W option, the -W terminal is at a DC potential as high as 400V when the prime power is on.

- 1) The AVD-3A-C unit consists of four basic components or modules:
 - a) Metal chassis
 - b) AVD-3A-PS module (Power Supply)
 - c) AVD-3A-T module (Pulse Generator)
 - d) +15V power supply board

The modules are interconnected as shown above.

- 2) If the unit malfunctions, disconnect from the 60 Hz supply and the trigger source and remove the two screws on each side of the unit. With the screws removed, the chassis cover consisting of the top and two sides will lift upwards exposing the modules shown above.
- 3) Reconnect to the 60 Hz source and check the voltage on the line connecting the 7815 output to pin 1 of the AVD-3A-PS module. A voltage of +15 volts should be recorded. If the voltage is substantially less than +15 volts, disconnect the 60 Hz source and disconnect the line from pin 1. Connect a 100 ohm 5 watt resistance to the output of the 7815. Reconnect to the 60 Hz source and measure the voltage across this resistor. A voltage of +15 volts should be indicated. If the voltage is substantially less than 15 volts the power supply module is defective and should be either repaired or replaced. If the measured voltage is equal to +15 volts then either the -PS or -T modules have failed. Disconnect the AVD-3A-T module from the AVD-3A mainframe and apply prime power and measure the voltage at pin 3. If this voltage is about 360 volts then the -T module has failed and should be returned to Avtech for repair or replacement. If the voltage is substantially less than 360 volts then the PS module has failed and should be returned to Avtech for repair.

