

# AVTECH ELECTROSYSTEMS LTD.

NANOSECOND WAVEFORM ELECTRONICS  
ENGINEERING – MANUFACTURING

□ P.O. BOX 265  
OGDENSBURG  
NEW YORK  
13669  
(315) 472-5270

BOX 5120, STN. "F"  
OTTAWA, ONTARIO  
CANADA K2C 3H4  
TEL: (613) 226-5772  
FAX: (613) 226-2802

## INSTRUCTIONS

MODEL AVO-3A-P-M1 PULSE GENERATOR

S.N. :

### WARRANTY

Avtech Electrosystems Ltd. warrants products of its manufacture to be free from defects in material and workmanship under conditions of normal use. If, within one year after delivery to the original owner, and after prepaid return by the original owner, this Avtech product is found to be defective, Avtech shall at its option repair or replace said defective item. This warranty does not apply to units which have been disassembled, modified or subjected to conditions exceeding the applicable specifications or ratings. This warranty is the extent of the obligation or liability assumed by Avtech with respect to this product and no other warranty or guarantee is either expressed or implied.

Fig. 1

AVO-3 TEST ARRANGEMENT

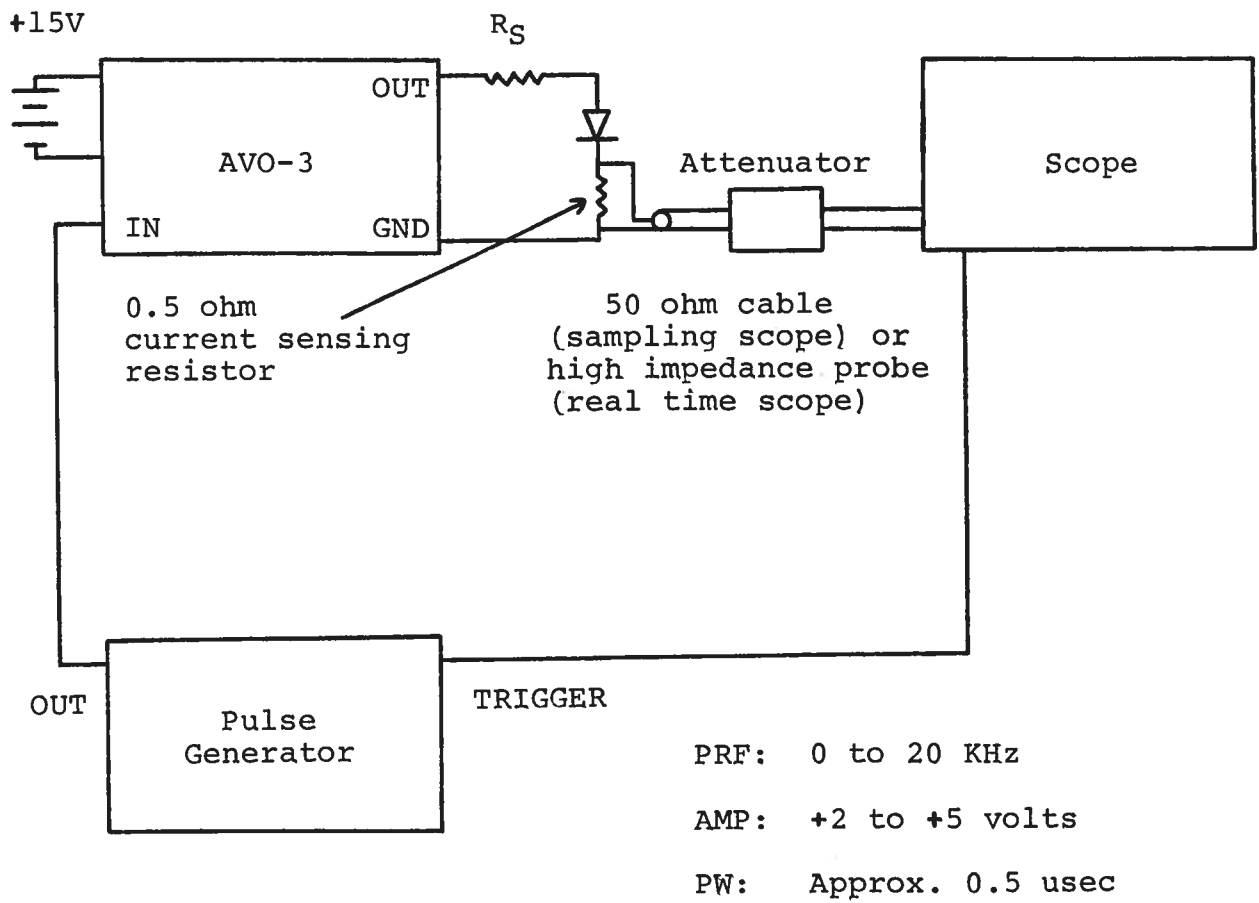

Notes:

- 1) The laser diode is connected in series with a current limiting resistor ( $0.5 < R_s < 5$  ohm) between the GND and OUT terminals on the front panel. In order to monitor the diode current a 0.5 ohm current sensing resistor may be connected in series with the diode and the resistor  $R_s$ . 1/4 watt carbon film or carbon composition resistors may be used but all leads must be as short as possible ( $\ll 0.1$  inch). Solder leads directly to the GND and OUT terminals. An alternative current monitoring arrangement employing a high impedance probe is shown in Fig. 2. With either arrangement (Fig. 1 or Fig. 2), some ringing may be observed following the output impulse. This ringing is largely the consequence of the exceedingly low probe load impedance.
- 2) In general the pulse generator trigger delay control should be set in 0.1 to 1.0 usec range. Other settings should be as shown in the above diagram.
- 3) Either a sampling oscilloscope or a high speed real time oscilloscope ( $BW > 500$  MHz) may be used to monitor the voltage across the current sensing resistor and therefore the laser diode current. If a sampling scope is used at least 60 db attenuation should be used to insure a scope input voltage of less than 1.0 volt.
- 4) The amplitude of the diode current is determined by the setting of the rear panel AMP pot control, the series resistor  $R_s$  and by the series resistance of the laser diode. With the LJ30 24 diode a series resistance of about 1.0 ohm should be adequate to obtain a peak current of 35 amperes. Shunt the output of the pulser with a 5.1 ohm resistor as shown. A SCHOTTKY diode may be placed across the laser diode to prevent any reverse potential (60 volt 1 Ampere units are adequate).
- 5) WARNING: The unit may fail if triggered at a PRF exceeding 20 KHz. Use moderate heat when soldering to the OUT terminal.

Fig. 2

AVO-3 TEST ARRANGEMENT

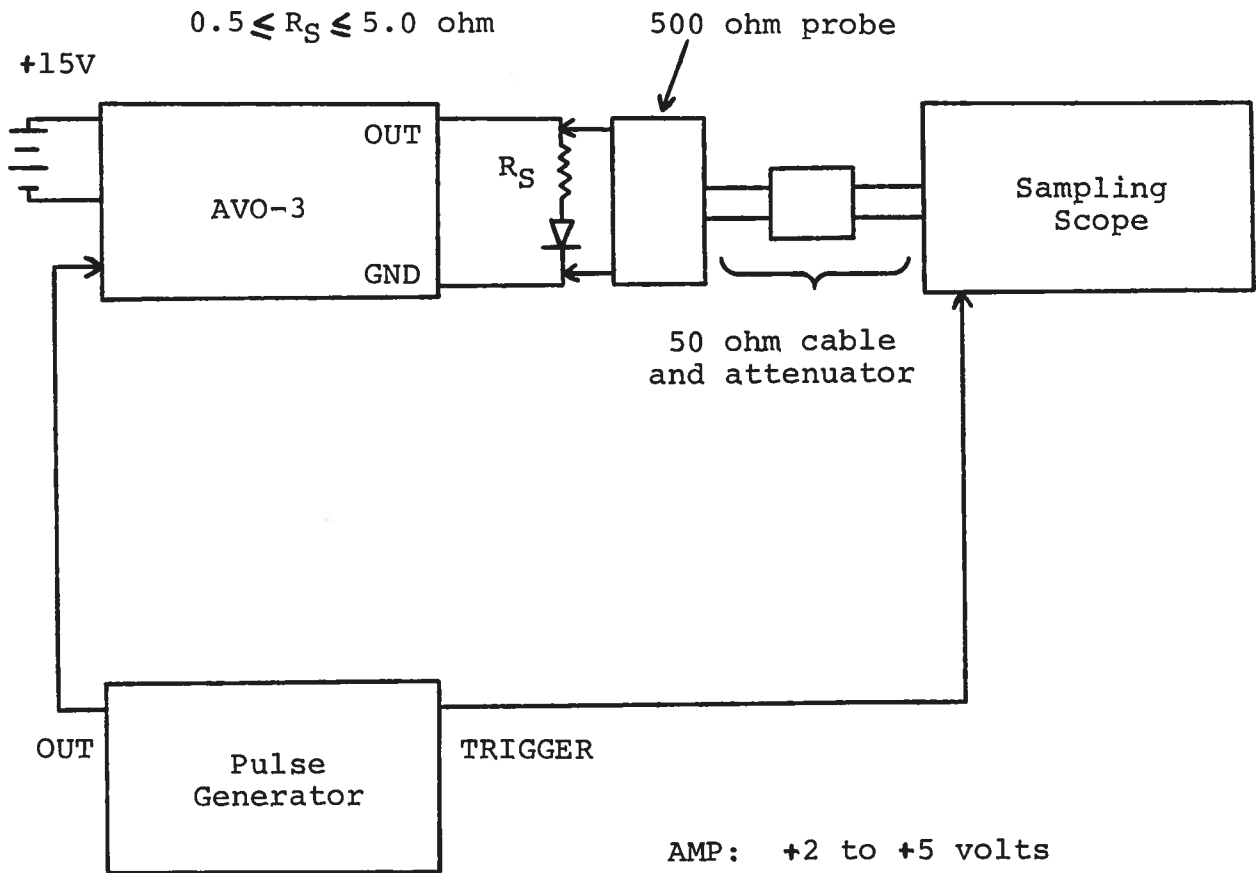

AMP: +2 to +5 volts  
PRF: 0 to 20.0 KHz  
PW: Approx. 0.5 usec

08.01.91 edition A