

# AVTECH ELECTROSYSTEMS LTD.

NANOSECOND WAVEFORM ELECTRONICS  
ENGINEERING - MANUFACTURING

□ P.O. BOX 265  
OGDENSBURG  
NEW YORK  
13669  
(315) 472-5270

✕ BOX 5120, STN. "F"  
OTTAWA, ONTARIO  
CANADA K2C 3H4  
TEL: (613) 226-5772  
FAX: (613) 226-2802  
TELEX: 053-4591

## INSTRUCTIONS

MODEL AVO-5-C-M-PN-EGG1 PULSE GENERATOR

S.N. :

### WARRANTY

Avtech Electrosystems Ltd. warrants products of its manufacture to be free from defects in material and workmanship under conditions of normal use. If, within one year after delivery to the original owner, and after prepaid return by the original owner, this Avtech product is found to be defective, Avtech shall at its option repair or replace said defective item. This warranty does not apply to units which have been disassembled, modified or subjected to conditions exceeding the applicable specifications or ratings. This warranty is the extent of the obligation or liability assumed by Avtech with respect to this product and no other warranty or guarantee is either expressed or implied.

Fig. 1

PULSE GENERATOR TEST ARRANGEMENT

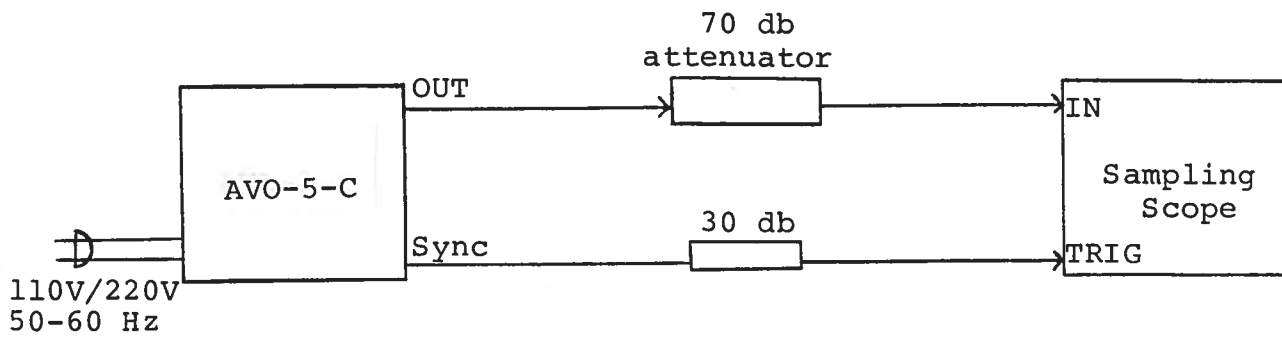

Notes:

- 1) The bandwidth capability of components and instruments used to display the pulse generator output signal (attenuators, cables, connectors, etc.) should exceed one gigahertz.
- 2) The use of 70 db attenuator at the sampling scope vertical input channel will insure a peak input signal to the sampling scope of less than one volt. WARNING: Model AVO-5-C may provide a peak output power in excess of 2.8 KW. The peak power rating of the attenuator must exceed this limit.
- 3) The sync output channel provides TTL level signals. To avoid overdriving the TRIG input channel of some sampling scopes, a 30 db attenuator should be placed at the input to the sampling scope trigger channel.
- 4) To obtain a stable output display the PRF and PRF FINE controls on the front panel should be set mid-range. The front panel TRIG toggle switch should be in the INT position. The front panel DELAY control and the scope triggering controls are then adjusted to obtain a stable output. The scope may then be used to set the desired PRF by rotating the PRF and PRF FINE controls. The main output is delayed with respect to the SYNC output by about 250 to 450 nsec depending on the DELAY control setting.
- 5) The output pulse width is controlled by means of the front panel one-turn PW control. The control should initially be set maximum clockwise and the pulse width adjusted using an oscilloscope.
- 6) The output pulse amplitude is controlled by means of the one turn potentiometer (AMP) and the HIGH-LOW switch adjacent to the AMP control. With the switch in the HIGH position, the output amplitude is variable over the range of 75 to 350 volts while in the LOW position the output amplitude is variable over the range of about 0 to 300 volts.
- 7) An external clock may be used to control the output PRF of the AVO-5 unit by setting the front panel TRIG toggle switch in the EXT position and applying a 0.2 usec (approx.) TTL level pulse to the TRIG BNC connector input. For operation in this mode, the scope time base must also be triggered by the external clock rather than from the SYNC output. WARNING: Model AVO-5 may fail if triggered at a PRF greater than 5 KHz.
- 8) Model AVO-5 can withstand an infinite VSWR on the output port but is intended for operation with 50 ohm loads.

- 9) NOTE: The lifetime of the switching elements in the pulse generator module is proportional to the running time of the instrument. For this reason the prime power to the instrument should be turned off when the instrument is not in use. In the case of failure, the switching elements are easily replaced following the procedure described in the following section.

Fig. 2

FRONT PANEL CONTROLS

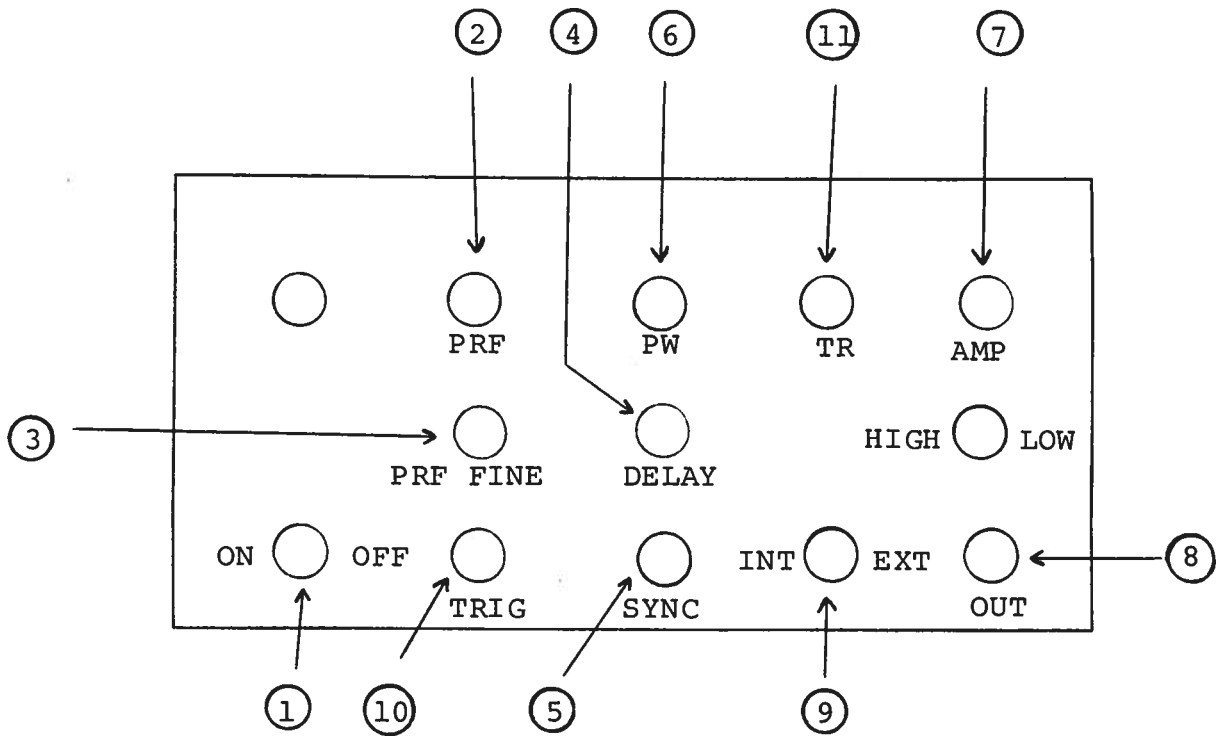

- (1) ON-OFF Switch. Applies basic prime power to all stages.
- (2) PRF Control. Varies PRF from about 50 Hz to about 5 KHz. The operating PRF should be set using a sampling scope.
- (3) PRF FINE Control. This control varies PRF but is about 10 times less sensitive than the main PRF control.
- (4) DELAY Control. Controls the relative delay between the reference output pulse provided at the SYNC output (5) and the main output (8). This delay is variable over the range of about 0 to 150 nsec.
- (5) SYNC Output. This output precedes the main output (8) and is used to trigger the sampling scope time base. The output is a TTL level 100 nsec (approx.) pulse capable of driving a fifty ohm load.
- (6) FW Control. A one-turn control which varies the output pulse width from 0 to 100 nsec.
- (7) AMP Control. The output pulse amplitude is controlled by means of the one-turn potentiometer (AMP) and the HIGH-LOW switch adjacent to the AMP control. With the switch in the HIGH position, the output amplitude is variable over the range of 75 to 350 volts while in the LOW position the output amplitude is variable over the range of about 0 to 300 volts.
- (8) OUT Connector. SMA connector provides output to a fifty ohm load.
- (9) EXT-INT Control. With this toggle switch in the INT position, the PRF of the AVO unit is controlled via an internal clock which in turn is controlled by the PRF and PRF FINE controls. With the toggle switch in the EXT position, the AVO unit requires a 0.2 usec TTL level pulse applied at the TRIG input in order to trigger the output stages. In addition, in this mode, the scope time base must be triggered by the external trigger source.
- (10) TRIG Input. The external trigger signal is applied at this input when the EXT toggle switch is in the EXT position. The output pulse at (8) appears about 350 nsec after the application of the TRIG pulse.
- (11) RISE TIME Control (Option). Varies rise and fall times in one nanosecond increments from about one to ten nanoseconds.

Fig. 3

BACK PANEL CONTROLS

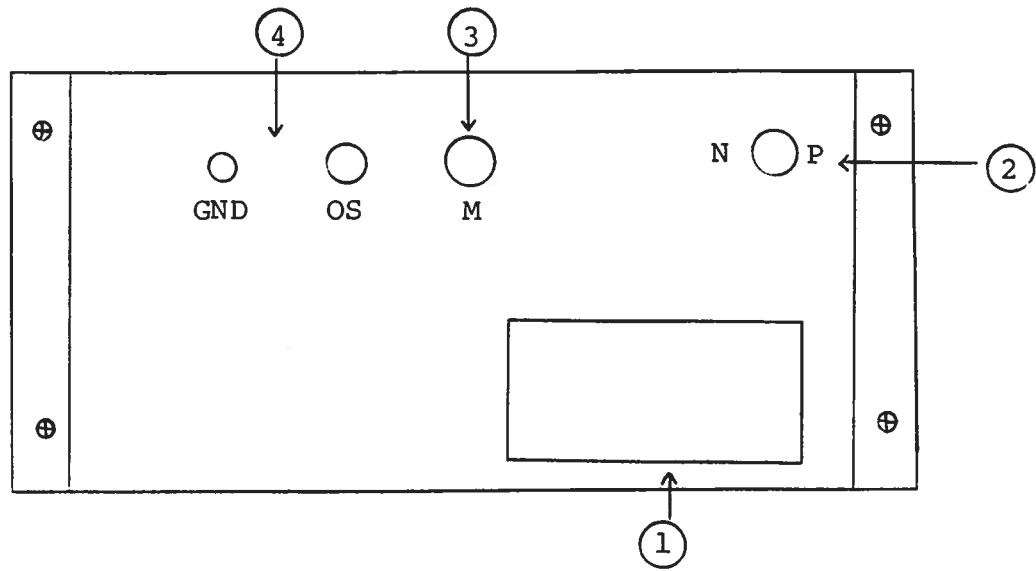



- (1) FUSED CONNECTOR, VOLTAGE SELECTOR. The detachable power cord is connected at this point. In addition, the removable cord is adjusted to select the desired input operating voltage. The unit also contains the main power fuse.
- (2) OUTPUT POLARITY CONTROL (Option). With switch in (P) position, output is positive. With switch in (N) position, output pulse is negative.
- (3) MONITOR Output. The back monitor output provides an attenuated replica (20 db down) of the output less DC offset. The monitor output is designed to operate into a 50 ohm load. (Option).
- (4) DC Offset (OS). The desired DC offset is applied to the back panel OS terminals which are connected to the output centre conductor via a high quality RF inductor. Do not exceed  $\pm 100V$ , 0.1 amp. (Option).

## REPAIR PROCEDURE

- 1) **WARNING:** Before attempting any repairs, note that potentials as high as 400 volts are employed in the chassis structure.
- 2) The pulse generator is constructed from the following basic subsystems or modules:
  - a) Metal chassis
  - b) Pulse generator module (AVO-5-PG)
  - c) Delay line module (AVO-5-DL)
  - d) Timing module (AVO-5-T)
  - e) Power supply module (AVO-5-PS)
  - f) Clock module (AVO-5-C)

The five modules are interconnected as shown in Fig. 4.

- 3) If no output pulse is provided by the AVO-5 unit, turn off the prime power supply and remove the top cover panel by removing the four Phillips screws on the back of the instrument (see Fig. 3). Apply a scope probe or voltmeter to pin 3 of the AVO-5-PG unit. With the unit untriggered, turn on the prime power supply. A voltage of about 360 to 380 volts should be read at pin 3. Alternatively, the voltage may be measured on the cases of the SL3 switching elements. If the voltage is zero or much less than 360 volts, then one of the switching transistors (Part No. SL3) in the AVO-5-PG module has probably failed. With the prime power supply off remove one of the transistors by removing the two 2-56 screws which secure the transistor in its socket. **CAUTION:** Before touching or removing the transistor, the cases should be briefly shorted to the instrument case to discharge charged capacitors (as high as 400 volts). Pull the transistor out of the socket. With the unit untriggered turn on the prime power supply and measure the voltage from the case of the remaining transistor to ground. If this voltage is about 360 to 380 volts then the transistor which was removed is defective and should be replaced. If the voltage which is measured is less than 360 volts then the transistor still in position is defective and should be replaced.

Note that the two transistors are completely interchangeable (Order Avtech Part No. SL3). Note that with both transistors removed, the voltage at pin 3 on the AVO-5-PG module should be in the range of 360 to 380 volts. If the voltage is less than the AVO-5-PS module must be replaced.

If both the AVO-5-PS module and the AVO-5-PG module are not found to be defective then the AVO-5-T module is suspect. Connect one scope probe to pin 3 of the -T module and a second probe to pin 2 of the -T module. With the scope triggered externally by the pulse generator providing the trigger input signal to the AVO unit, the waveform at pins 2 and 3 of the -T module should resemble:

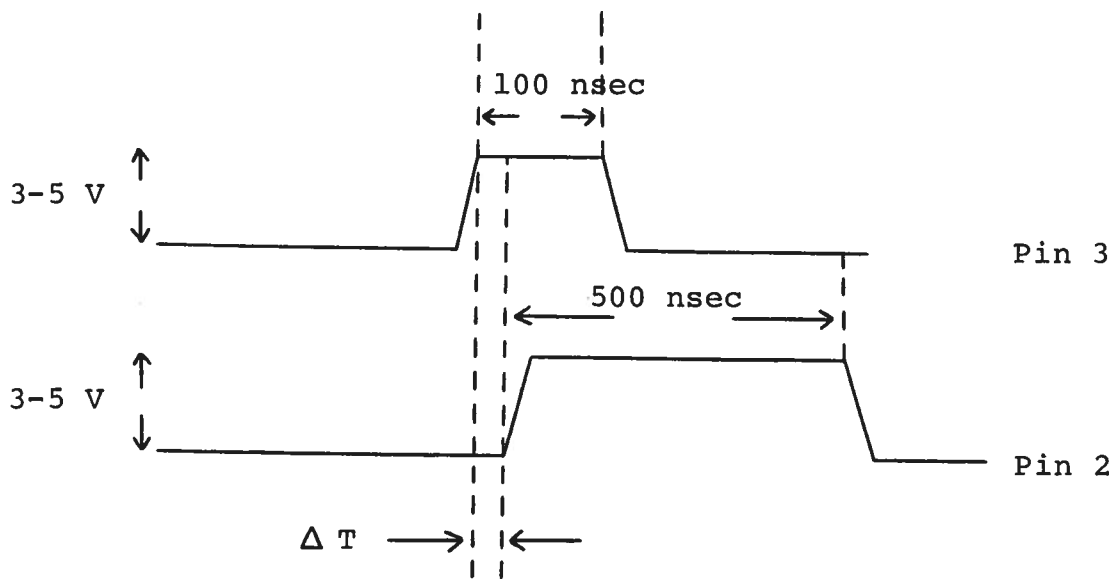

## T MODULE WAVEFORMS

As the PW pot is varied over its full range  $\Delta T$  should vary from about 0 to approximately 100 nsec. If the waveforms at pins 2 and 3 do not resemble the above, then the -T module is defective and should be replaced. If the waveforms do resemble the above then the -PG module is at fault and should be replaced.

Replacement modules should be ordered by part No. (eg. AVO-5-PG) from Avtech.

Fig. 4 System Block Diagram With Wiring and Pin Connections

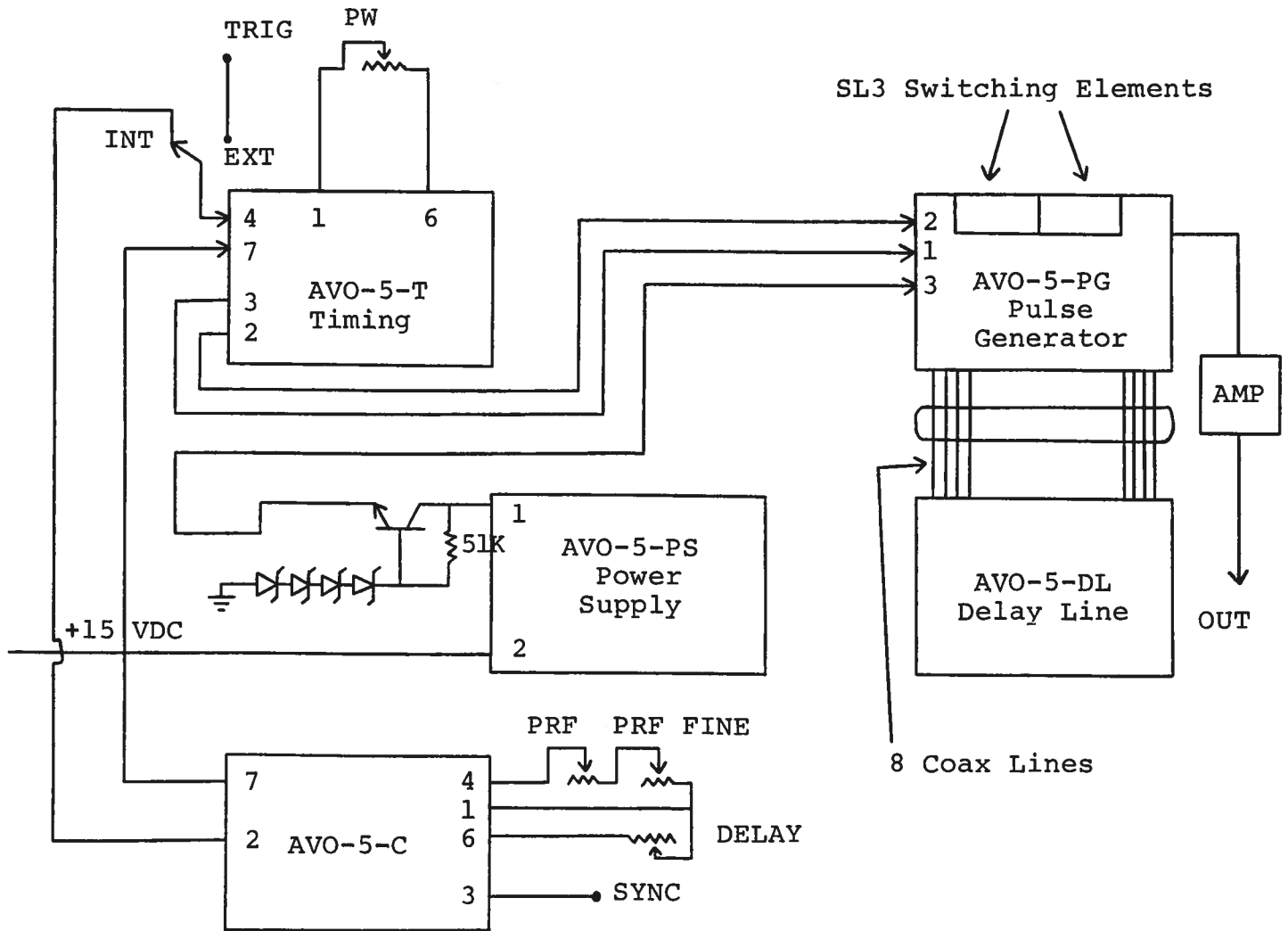

Notes:

- 1) All module chassis are grounded to main chassis and to each other via separate ground lines.
- 2) **WARNING:** The line connecting pin 1 of AVO-5-PS to pin 3 of AVO-5-PG is at a potential of 360 to 380 volts.

Fig. 6

+15 V POWER SUPPLY BOARD

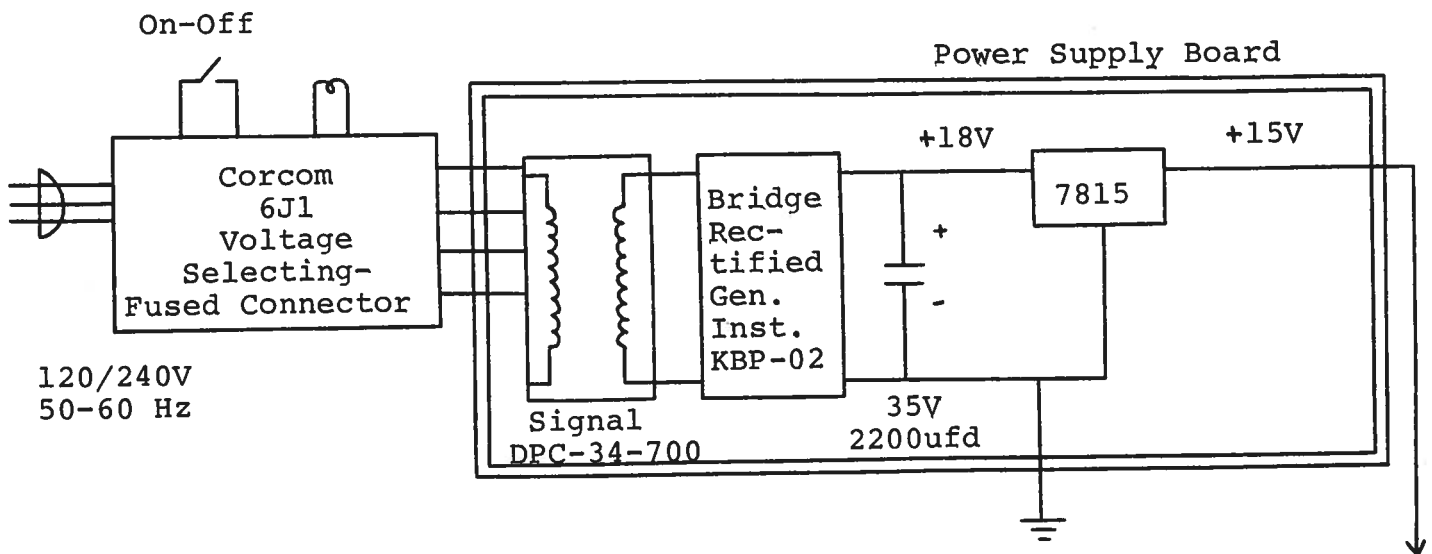

## +15 VOLT POWER SUPPLY

The AVO-5-C consists of the five standard modules and a power supply board which supplies +15 volts (600 mA max) to the pulse generator modules. In the event that the AVO-5-C unit malfunctions, remove the instrument cover by removing the two screws on each side of the unit, thereby exposing the modules. Measure the voltage at the +15 V pin of the PS module. If this voltage is substantially less than +15 volts, unsolder the line connecting the power supply board output and connect a 50 ohm 10 W load to the power supply output. The voltage across this load should be about 15 V DC. If this voltage is substantially less than 15 volts the power supply board is defective and should be repaired or replaced. If the voltage is near +15V then see instructions in preceding section.

Schroff

11.28.90

-05