



AVTECH ELECTROSYSTEMS LTD.

NANOSECOND WAVEFORM ELECTRONICS
SINCE 1975

□ P.O. BOX 265
OGDENSBURG, NY
U.S.A. 13669-0265
TEL: (315) 472-5270
FAX: (613) 226-2802

TEL: 1-800-265-6681
FAX: 1-800-561-1970
U.S.A. & CANADA

□ BOX 5120 STN. F
OTTAWA, ONTARIO
CANADA K2C 3H4
TEL: (613) 226-5772
FAX: (613) 226-2802

INSTRUCTIONS

MODEL AVO-5A1-C-PN-M-T3 PULSE GENERATOR

S.N. :

WARRANTY

Avtech Electrosystems Ltd. warrants products of its manufacture to be free from defects in material and workmanship under conditions of normal use. If, within one year after delivery to the original owner, and after prepaid return by the original owner, this Avtech product is found to be defective, Avtech shall at its option repair or replace said defective item. This warranty does not apply to units which have been disassembled, modified or subjected to conditions exceeding the applicable specifications or ratings. This warranty is the extent of the obligation or liability assumed by Avtech with respect to this product and no other warranty or guarantee is either expressed or implied.

Fig. 1 PULSE GENERATOR TEST ARRANGEMENT

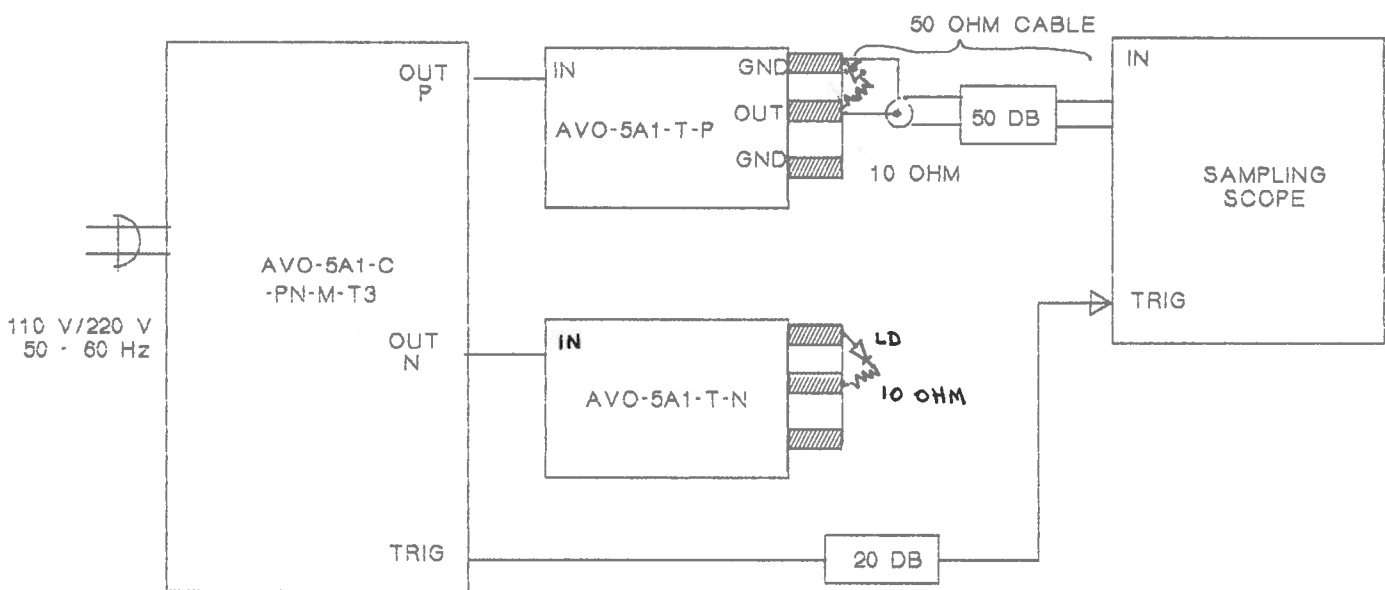

Notes:

- 1) The bandwidth capability of components and instruments used to display the pulse generator output signal (attenuators, cables, connectors, etc.) should exceed one gigahertz.
- 2) The output polarity is controlled by the front panel two position polarity switch.
- 3) The use of 50 db attenuator at the sampling scope vertical input channel will insure a peak input signal to the sampling scope of less than one volt.
- 4) The TRIG output channel provides TTL level signals. To avoid overdriving the TRIG input channel of some sampling scopes, a 20 db attenuator should be placed at the input to the sampling scope trigger channel.
- 5) To obtain a stable output display the PRF controls on the front panel should be set mid-range. The front panel TRIG toggle switch should be in the INT position. The front panel DELAY control and the scope triggering controls are then adjusted to obtain a stable output. The scope may then be used to set the desired PRF by rotating the PRF. The main output is delayed with respect to the TRIG output by about 250 to 450 ns depending on the DELAY control setting.
- 6) The output pulse width is controlled by means of the front panel one turn PW control. The control should initially be set maximum clockwise and the pulse width adjusted using an oscilloscope. To voltage control the output pulse width, remove the jumper wire between banana plugs A and B on the back panel and apply 0 to +10V to connector B (RIN > 10K). (EW option).
- 7) The output pulse amplitude is controlled by means of the one turn potentiometer (AMP) and the HIGH-LOW switch adjacent to the AMP control. With the switch in the HIGH position, the output amplitude is variable over the range of 4 to 18 amps while in the LOW position the output amplitude is variable over the range of about 0 to 15 amps.
- 8) An external clock may be used to control the output PRF of the AVO unit by setting the front panel TRIG toggle switch in the EXT position and applying a 0.2 usec (approx) TTL level pulse to the TRIG BNC connector input. For operation in this mode, the scope time base must also be triggered by the external clock rather than from the SYNC output. WARNING: Model AVO-5 may fail if triggered at a PRF greater than 5 KHz.

- 9) The AVO-5-T transformer module transforms the 360 volt output of the AVO-5A1 mainframe to 100 volts to 10 ohm. The AVO-5-T module connects to the mainframe via a 50 ohm miniature coaxial cable approx. 2 feet in length. The output terminals of the transformer module consists of a short length of microstrip transmission line protruding from the module chassis. The OUT terminal is the center conductor which is bounded on both sides by the ground plane (see below):

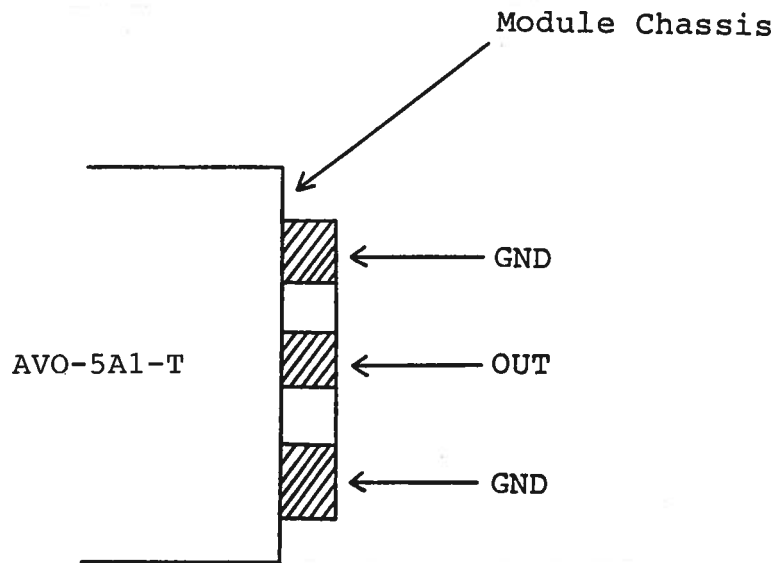

The diode load and series resistor (10 ohm 1/4 W carbon composition resistor) should be connected between the OUT and GND terminals using very short leads (< 0.2 cm). The voltage across the resistor-diode load may be monitored by connecting a length of 80 mil semi-rigid 50 ohm cable as shown below:

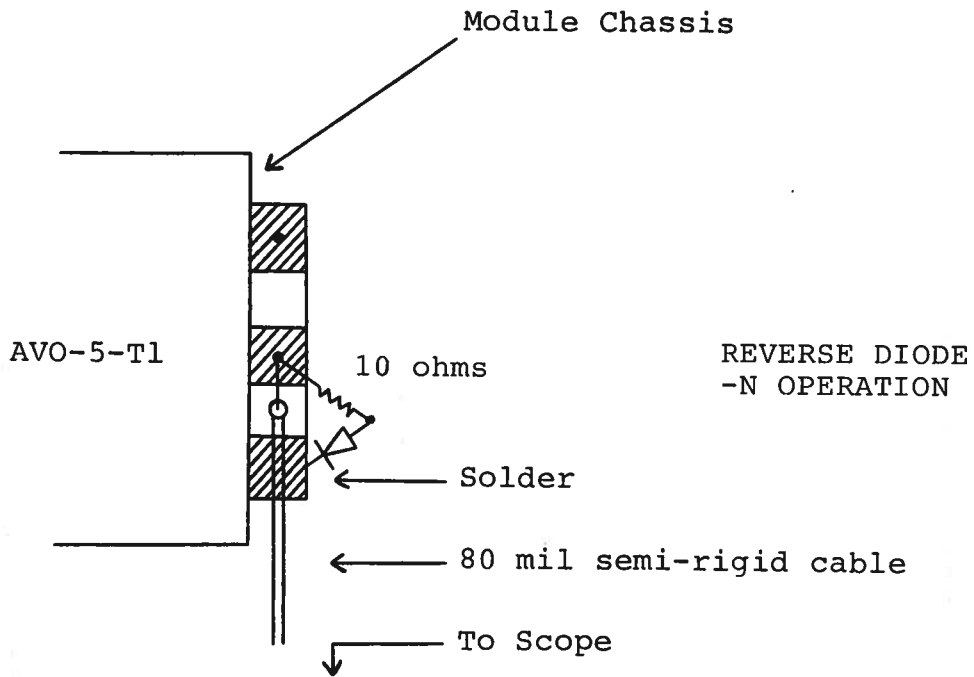

Take care to insure that during soldering the OUT conductor is not shorted to the chassis. Also, use minimal heat when soldering.

- 10) To obtain peak currents in the range of 0 to 7 amperes the diode load in series with a 47 ohm resistor may be connected directly on the output of the AVO-5 mainframe as shown below:

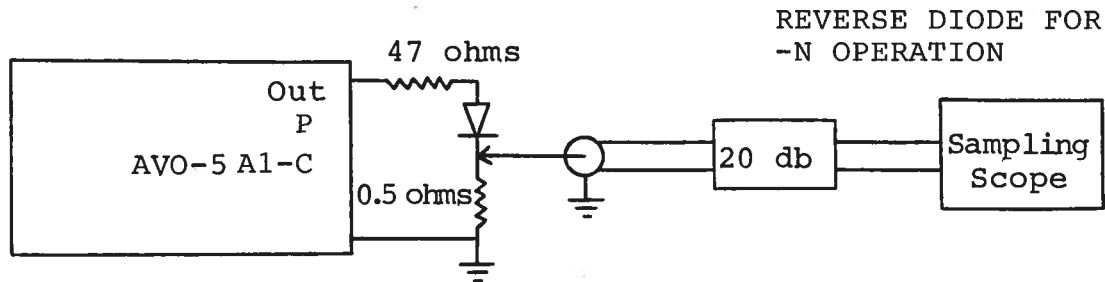

The output current may be observed by placing a 0.5 ohm carbon composition resistor in series with the diode and placing a 50 ohm cable across this resistor.

11) NOTE: The lifetime of the switching elements in the pulse generator module is proportional to the running time of the instrument. For this reason the prime power to the instrument should be turned off when the instrument is not in use. In the case of failure, the switching elements are easily replaced following the procedure described in the following section.

12) The unit can be converted from 110 to 220V 50-60 Hz operation by adjusting the voltage selector card in the rear panel fused voltage selector-cable connector assembly.

13) For additional assistance:

Tel: (613) 226-5572

Fax: (613) 226-2802

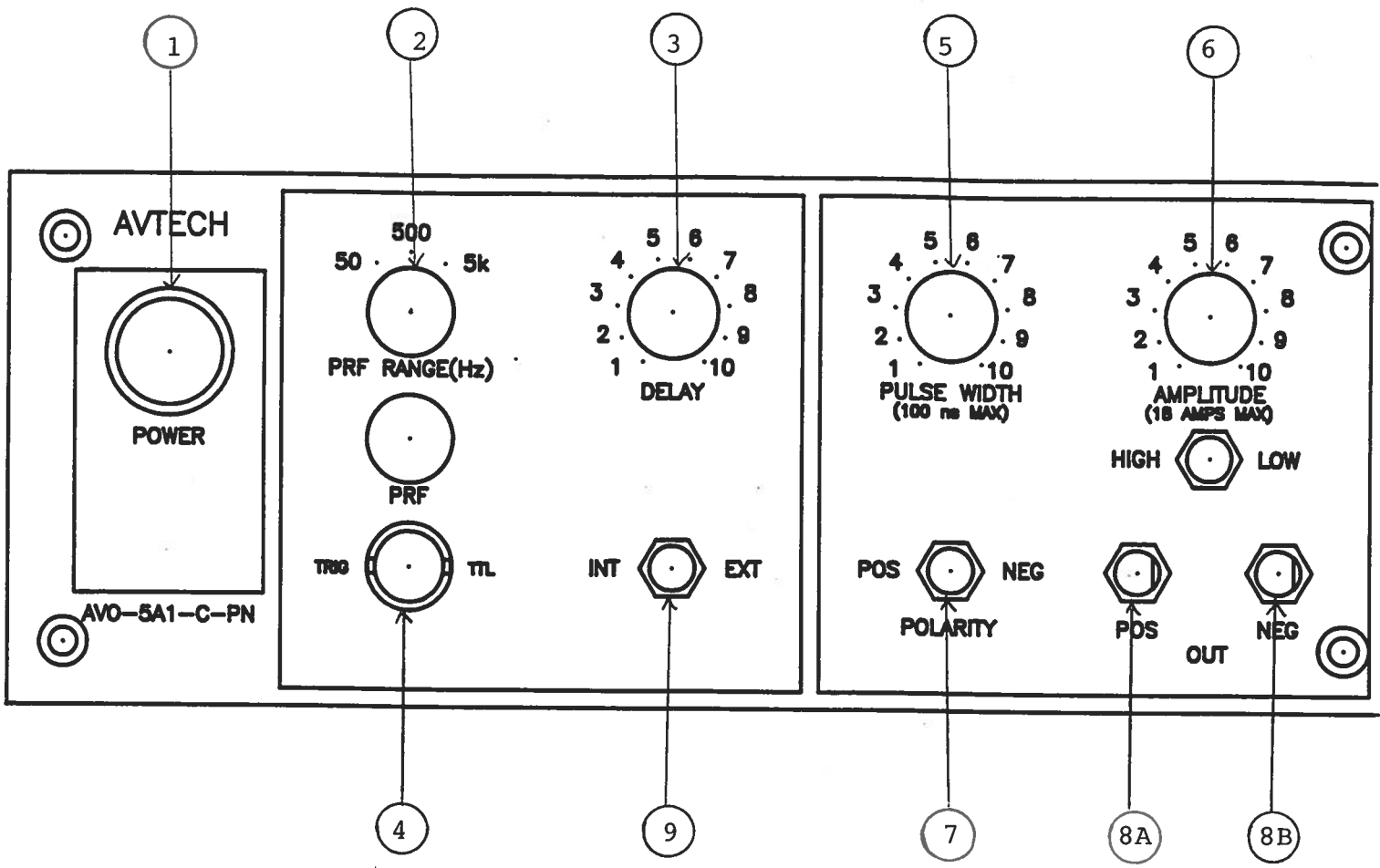

Fig. 2

FRONT PANEL CONTROLS

- (1) ON-OFF Switch. Applies basic prime power to all stages.
- (2) PRF Control. Varies PRF from about 5 Hz to about 5 KHz as follows:
 - 5 Hz - 50 Hz
 - 50 Hz - 500 Hz
 - 500 Hz - 5 kHz
- (3) DELAY Control. Controls the relative delay between the reference output pulse provided at the TRIG output (4) and the main output (8). This delay is variable over the range of about 50 to 450 ns.
- (4) TRIG Output. This output precedes the main output (8) and is used to trigger the sampling scope time base. The output is a TTL level 100 ns (approx) pulse capable of driving a fifty ohm load.
- (5) PW Control. A one turn control which varies the output pulse width from 0 to 100 ns.
- (6) AMP Control. The output pulse amplitude is controlled by means of the one turn potentiometer (AMP) and the HIGH-LOW switch adjacent to the AMP control. With the switch in the HIGH position, the output amplitude is variable over the range of 4 to 18 amps while in the LOW position the output amplitude is variable over the range of about 0 to 15 amps.
- (7) POLARITY. Two position switch controls activates the P_{OUT} (8A) or the N_{OUT} (8B) ports.
- (8) OUT Connectors. SMA connector provides output to a fifty ohm load (0 to 360 volts). The 50 Ohm cable from the AVO-5A1-T modules connects to these points.
- (9) EXT-INT Control. With this toggle switch in the INT position, the PRF of the AVO unit is controlled via an internal clock which in turn is controlled by the PRF controls. With the toggle switch in the EXT position, the AVO unit requires a 0.2 usec TTL level pulse applied at the TRIG input in order to trigger the output stages. In addition, in this mode, the scope time base must be triggered by the external trigger source.

Fig. 3

BACK PANEL CONTROLS

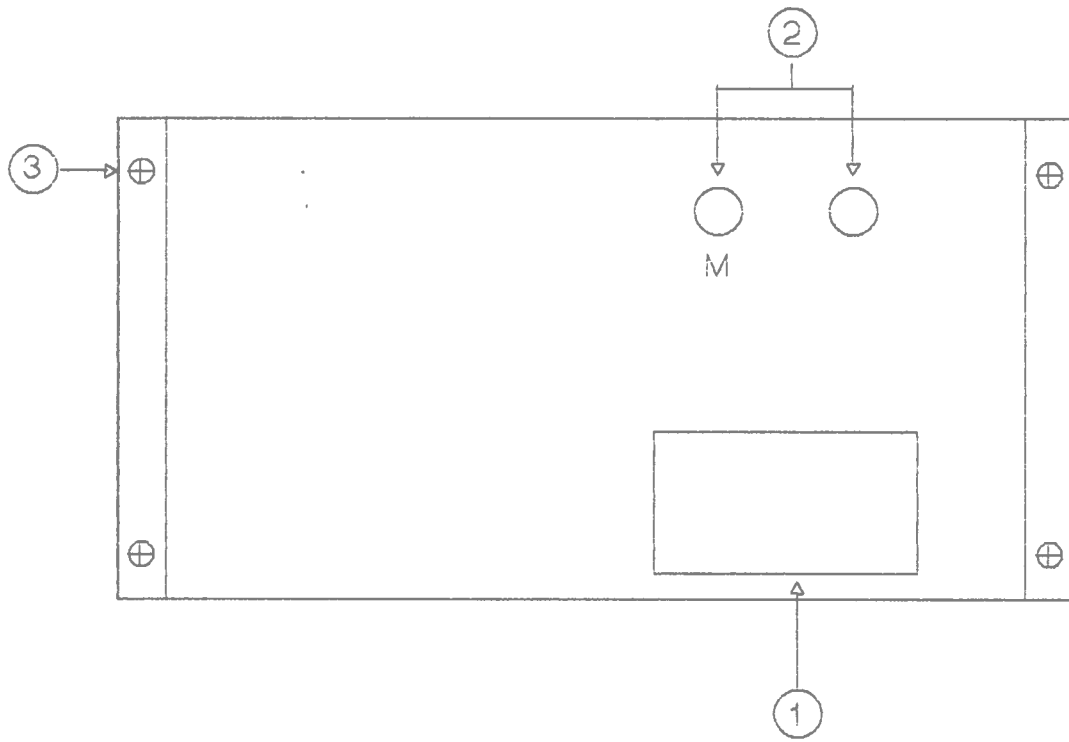

- (1) FUSED CONNECTOR, VOLTAGE SELECTOR. The detachable power cord is connected at this point. In addition, the removable cord is adjusted to select the desired input operating voltage. The unit also contains the main power fuse. (0.5 A SB)
- (2) MONITOR Output (option). The back panel monitor output port provides an output voltage to 50 ohms which is 20 times the amplitude appearing at the AVO-5A1-T output terminals. The diode load current can be computed as follows:

$$I_{DIODE} = \frac{0.05V_M - V_{DIODE}}{R_{SERIES}}$$

where V_M = M output port voltage to 50 ohm

V_{DIODE} = voltage across the laser diode

R_{SERIES} = resistance placed in series between AVO-5A1-T output and laser diode

- (3) COVER SCREWS. To remove top lid of instrument, remove four Phillips screws and slide top lid back to expose interior.

REPAIR PROCEDURE

- 1) **WARNING:** Before attempting any repairs, note that potentials as high as 400 volts are employed in the chassis structure.
- 2) The pulse generator is constructed from the following basic subsystems or modules:
 - a) Metal chassis
 - b) Pulse generator module (AVO-5A1-PG)
 - c) Delay line module (AVO-5A1-DL)
 - d) Timing module (AVO-5A1-T)
 - e) Power supply module (AVO-5A1-PS)
 - f) Clock module (AVO-5A1-C)
 - g) Power supply module (PS-20)
 - h) Monitor modules (M-P and M-N)

The eight modules are interconnected as shown in Fig. 4.

- 3) If no output pulse is provided by the AVO-5 unit, turn off the prime power supply and remove the top cover panel by removing the four Phillips screws on the back of the instrument (see Fig. 3). Apply a scope probe or voltmeter to pin 3 of the AVO-5-PG unit. With the unit untriggered, turn on the prime power supply. A voltage of about 360 to 380 volts should be read at pin 3. Alternatively, the voltage may be measured on the cases of the SL3 switching elements. If the voltage is zero or much less than 360 volts, then one of the switching transistors (Part No. SL3) in the AVO-5-PG module has probably failed. With the prime power supply off remove one of the transistors by removing the two 2-56 screws which secure the transistor in its socket. **CAUTION:** Before touching or removing the transistor, the cases should be briefly shorted to the instrument case to discharge charged capacitors (as high as 400 volts). Pull the transistor out of the socket. With the unit untriggered turn on the prime power supply and measure the voltage from the case of the remaining transistor to ground. If this voltage is about 360 to 380 volts then the transistor which was removed is defective and should be replaced. If the voltage which is measured is less than 360 volts then the transistor still in position is defective and should be replaced.

If both the AVO-5-PS module and the AVO-5-PG module are not found to be defective then the AVO-5-T module is suspect. Connect one scope probe to pin 3 of the -T module and a second probe to pin 2 of the -T module. With the scope triggered externally by the pulse generator providing the trigger input signal to the AVO unit, the waveform at pins 2 and 3 of the -T module should resemble:

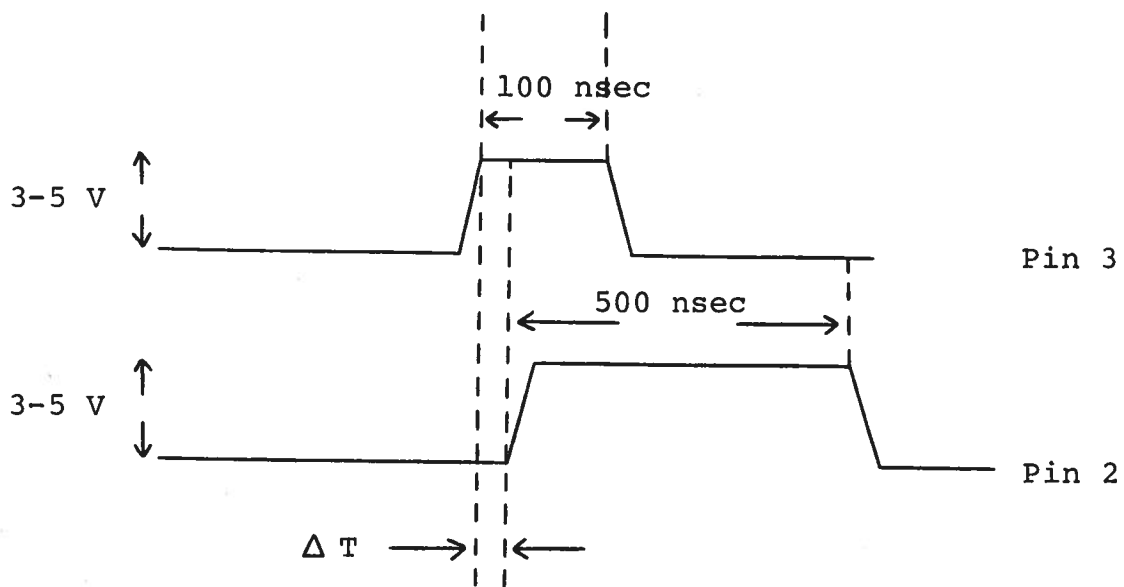

T MODULE WAVEFORMS

As the PW pot is varied over its full range ΔT should vary from about 0 to approximately 100 nsec. If the waveforms at pins 2 and 3 do not resemble the above, then the -T module is defective and should be replaced. If the waveforms do resemble the above then the -PG module is at fault and should be replaced.

Replacement modules should be ordered by part No. (eg. AVO-5-PG) from Avtech.

Fig. 4 System Block Diagram With Wiring and Pin Connections

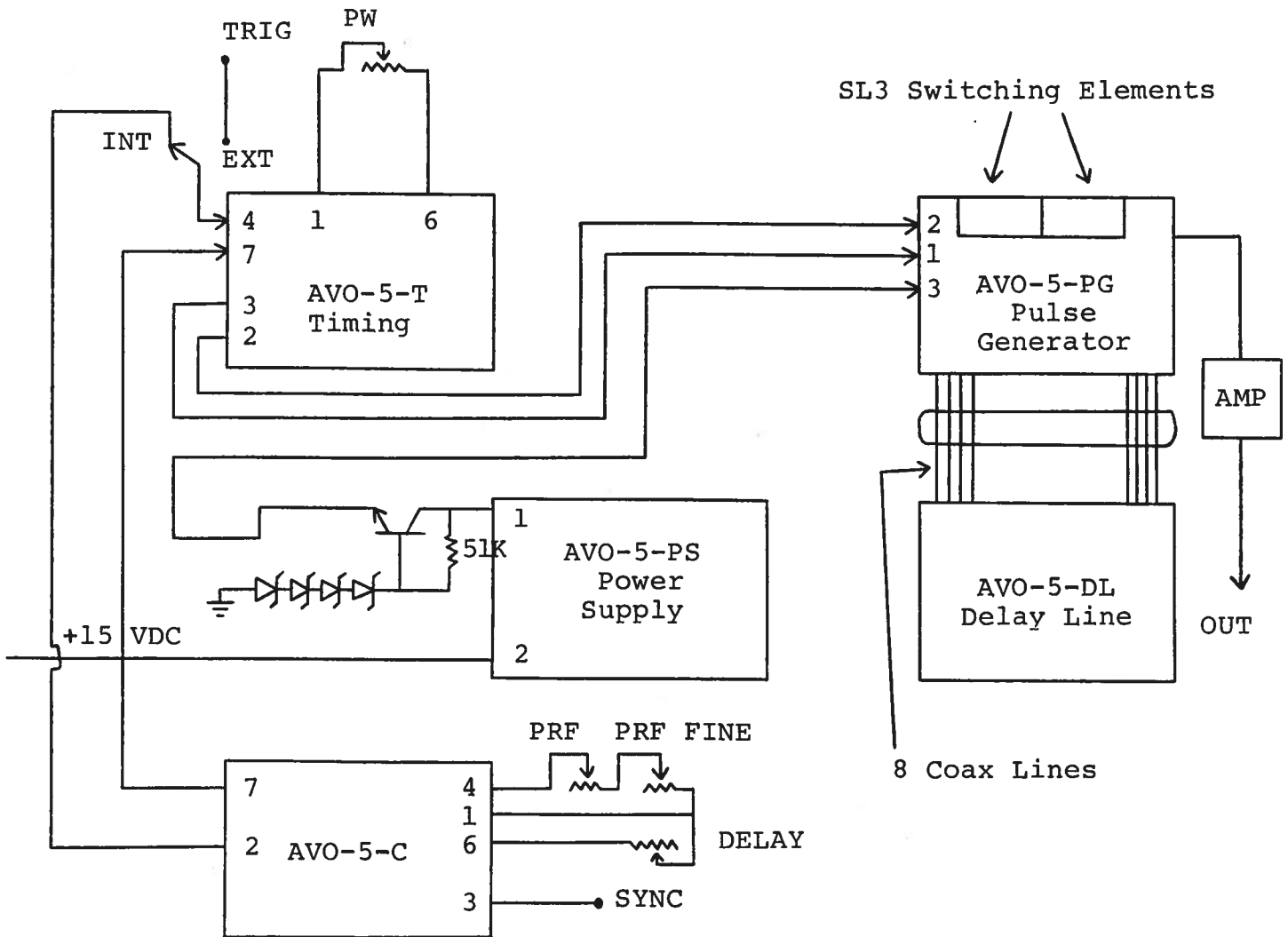

Notes:

- 1) All module chassis are grounded to main chassis and to each other via separate ground lines.
- 2) **WARNING:** The line connecting pin 1 of AVO-5-PS to pin 3 of AVO-5-PG is at a potential of 360 to 380 volts.

Fig. 6

+15 V POWER SUPPLY BOARD

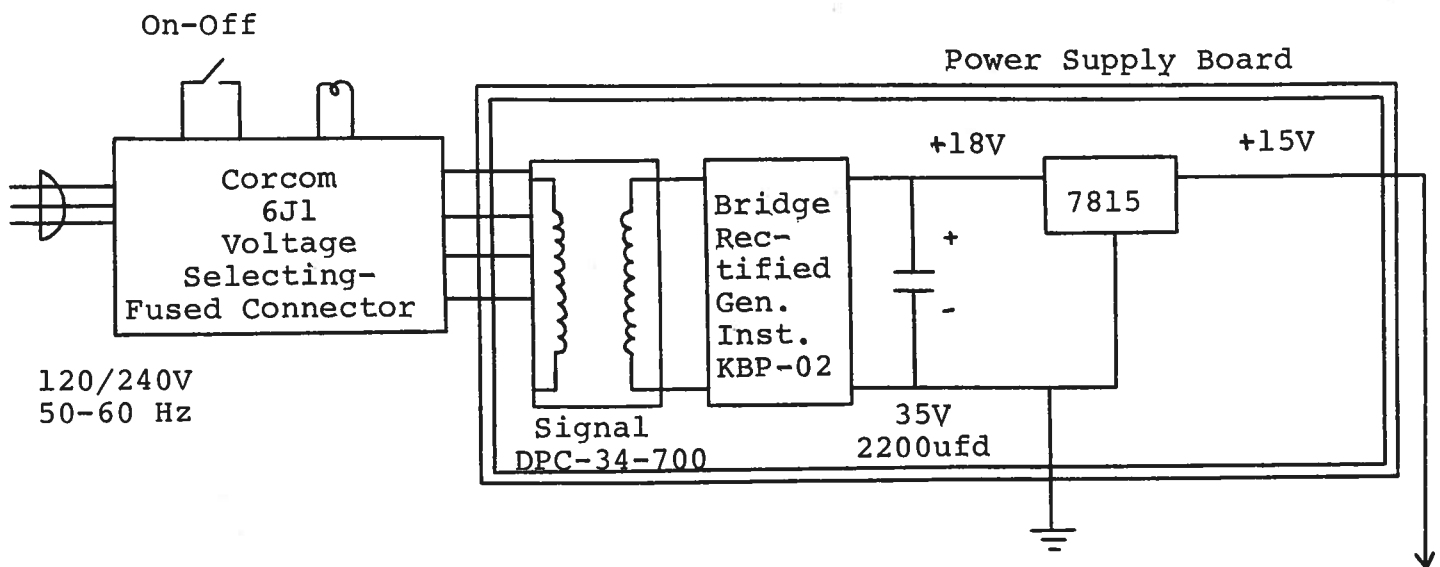

To Fig. 4

+15 VOLT POWER SUPPLY

The AVO-5-C consists of the five standard modules and a power supply board which supplies +15 volts (600 mA max) to the pulse generator modules. In the event that the AVO-5-C unit malfunctions, remove the instrument cover by removing the two screws on each side of the unit, thereby exposing the modules. Measure the voltage at the +15 V pin of the PS module. If this voltage is substantially less than +15 volts, unsolder the line connecting the power supply board output and connect a 50 ohm 10 W load to the power supply output. The voltage across this load should be about 15 V DC. If this voltage is substantially less than 15 volts the power supply board is defective and should be repaired or replaced. If the voltage is near +15V then see instructions in preceding section.