

AVTECH ELECTROSYSTEMS LTD.

**NANOSECOND WAVEFORM ELECTRONICS
ENGINEERING . MANUFACTURING**

□ P.O. BOX 265
OGDENSBURG
NEW YORK
13669
(315) 472-5270

BOX 5120 STN. "F"
OTTAWA, ONTARIO
CANADA K2C 3H4
(613) 226-5772
TELEX 053-4591

INSTRUCTIONS

MODEL AVO-5B-C PULSE GENERATOR

S.N. :

WARRANTY

Avtech Electrosystems Ltd. warrants products of its manufacture to be free from defects in material and workmanship under conditions of normal use. If, within one year after delivery to the original owner, and after prepaid return by the original owner, this Avtech product is found to be defective, Avtech shall at its option repair or replace said defective item. This warranty does not apply to units which have been disassembled, modified or subjected to conditions exceeding the applicable specifications or ratings. This warranty is the extent of the obligation or liability assumed by Avtech with respect to this product and no other warranty or guarantee is either expressed or implied.

Fig. 1

PULSE GENERATOR TEST ARRANGEMENT

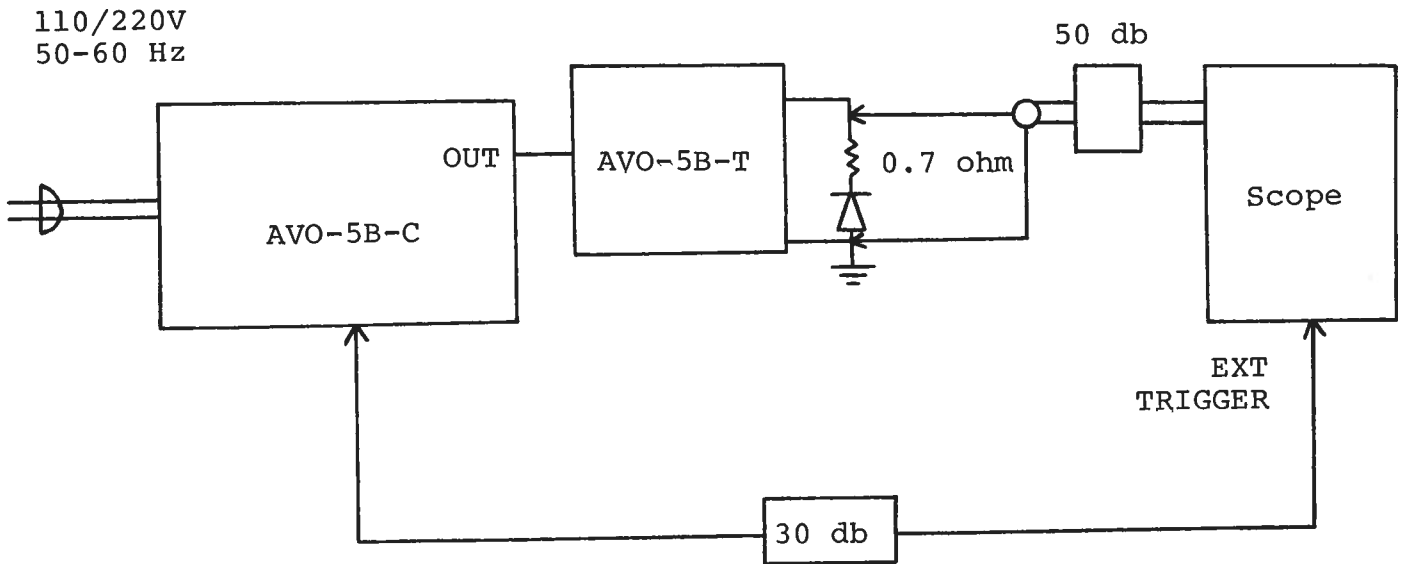

Notes:

- 1) The equipment should be connected in the general fashion shown above. Since the AVO unit provides an output pulse rise time as low as 10 nsec a fast oscilloscope (at least 50 MHz and preferably 200 MHz) should be used to display the waveform. If a sampling scope is used, a 50 db (or greater) attenuator should be used to insure a peak input to the scope of less than 0.5 volts.
- 2) The sync output channel provides TTL level signals. To avoid overdriving the TRIG input channel of some sampling scopes, a 30 db attenuator should be placed at the input to the sampling scope trigger channel.
- 3) To obtain a stable output display the PRF and PRF FINE controls on the front panel should be set mid-range. The front panel TRIG toggle switch should be in the INT position. The front panel DELAY control and the scope triggering controls are then adjusted to obtain a stable output. The scope may then be used to set the desired PRF by rotating the PRF and PRF FINE controls. The main output is delayed with respect to the SYNC output by about 0 to 200 nsec depending on the DELAY control setting.
- 4) The AVO-5B-T transformer module transforms the 150 volt output of the AVO-5B mainframe to 37 volts to 0.75 ohm. The AVO-5B-T module connects to the mainframe via four parallel 50 ohm miniature coaxial cables approx. 2 feet in length. The output terminals of the transformer module consists of a short length of microstrip transmission line protruding from the module chassis. The OUT terminal is the center conductor which is bounded on both sides by the ground plane (see below):

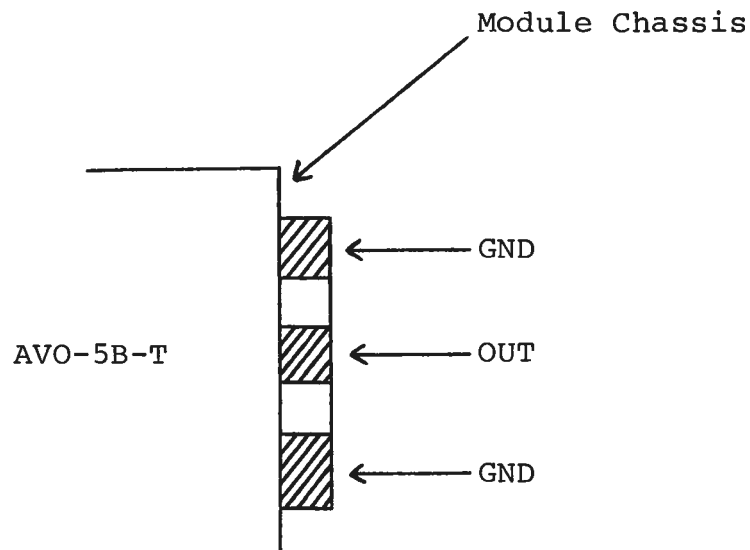

The diode load and series resistor (0.7 to 0.75 ohm 1/4 W carbon composition resistor) should be connected between the OUT and GND terminals using very short leads ($\ll 0.2$ cm). The voltage across the resistor-diode load may be monitored by connecting a length of 80 mil semi-rigid 50 ohm cable as shown below:

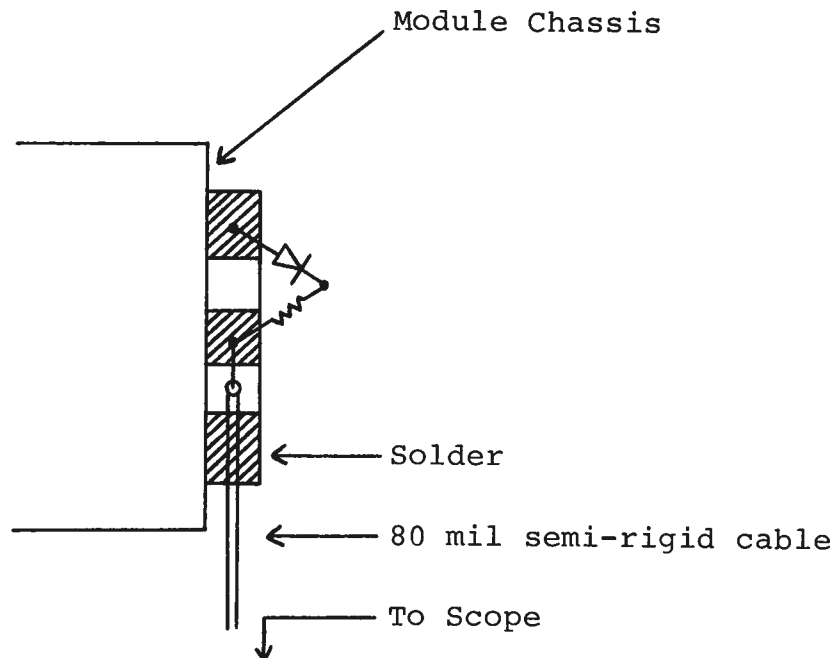

Take care to insure that during soldering the OUT conductor is not shorted to the chassis. Also, use minimal heat when soldering.

- 5) To voltage control the output pulse width, remove the jumper wire between banana plugs A and B on the back panel and apply 0 to +10V to connector B ($R_{IN} \gg 10K$). (option).
- 6) To voltage control the output amplitude, remove the jumper wire between banana plugs A and B on the back panel and apply 0 to +10V to connector B ($R_{IN} \gg 10K$). (option).

Fig. 2

FRONT PANEL CONTROLS

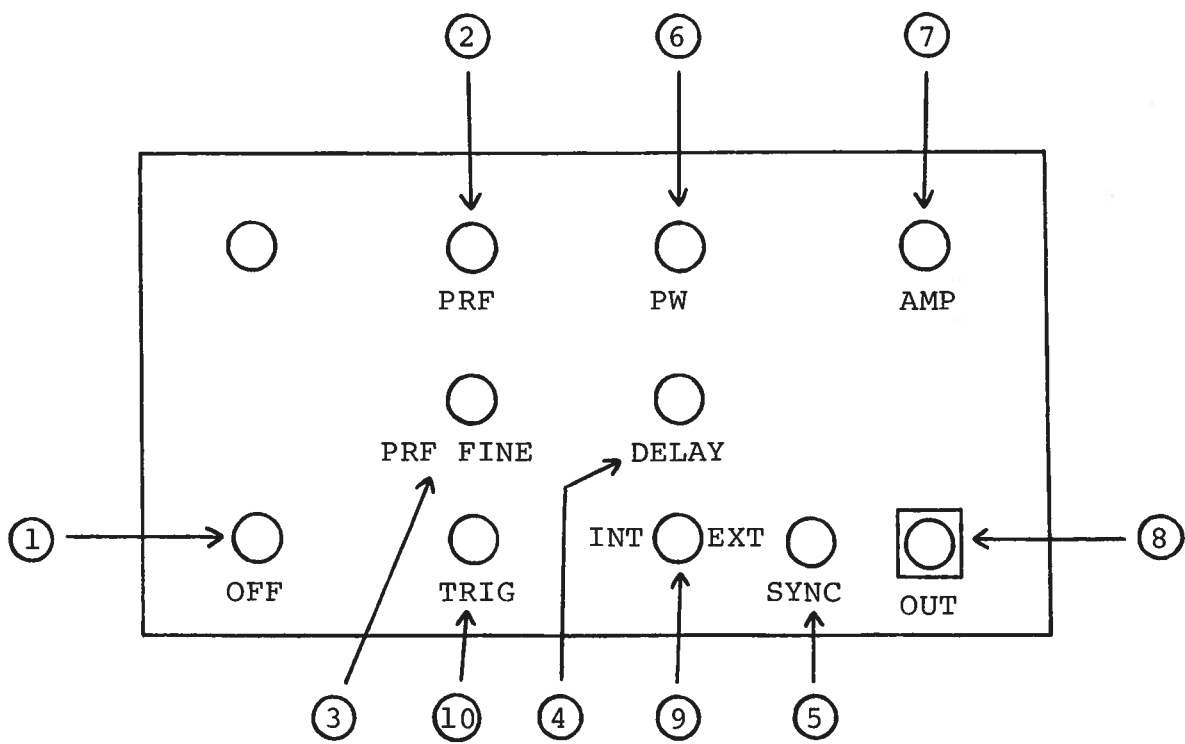

- (1) ON-OFF Switch. Applies basic prime power to all stages.
- (2) PRF Control. Varies PRF from about 50 Hz to about 5 KHz. The operating PRF should be set using a sampling scope.
- (3) PRF FINE Control. This control varies PRF but is about 10 times less sensitive than the main PRF control.
- (4) DELAY Control. Controls the relative delay between the reference output pulse provided at the SYNC output (5) and the main output (8). This delay is variable over the range of about 0 to 200 nsec.
- (5) SYNC Output. This output precedes the main output (8) and is used to trigger the sampling scope time base. The output is a TTL level 100 nsec (approx) pulse capable of driving a fifty ohm load.
- (6) PW Control. A one turn control which varies the output pulse width from 25 to 500 nsec.
- (7) AMP Control. The output pulse amplitude is controlled by means of the one turn potentiometer (AMP).
- (8) OUT Connectors. Four SMA connectors for four miniature coaxial cables connected to the AVO-5B-T module.
- (9) EXT-INT Control. With this toggle switch in the INT position, the PRF of the AVO unit is controlled via an internal clock which in turn is controlled by the PRF and PRF FINE controls. With the toggle switch in the EXT position, the AVO unit requires a 0.2 usec TTL level pulse applied at the TRIG input in order to trigger the output stages. In addition, in this mode, the scope time base must be triggered by the external trigger source.
- (10) TRIG Input. The external trigger signal is applied at this input when the EXT-INT toggle switch is in the EXT position. The output pulse at (8) appears about 30 nsec after the application of the TRIG pulse.

Fig. 3

BACK PANEL CONTROLS

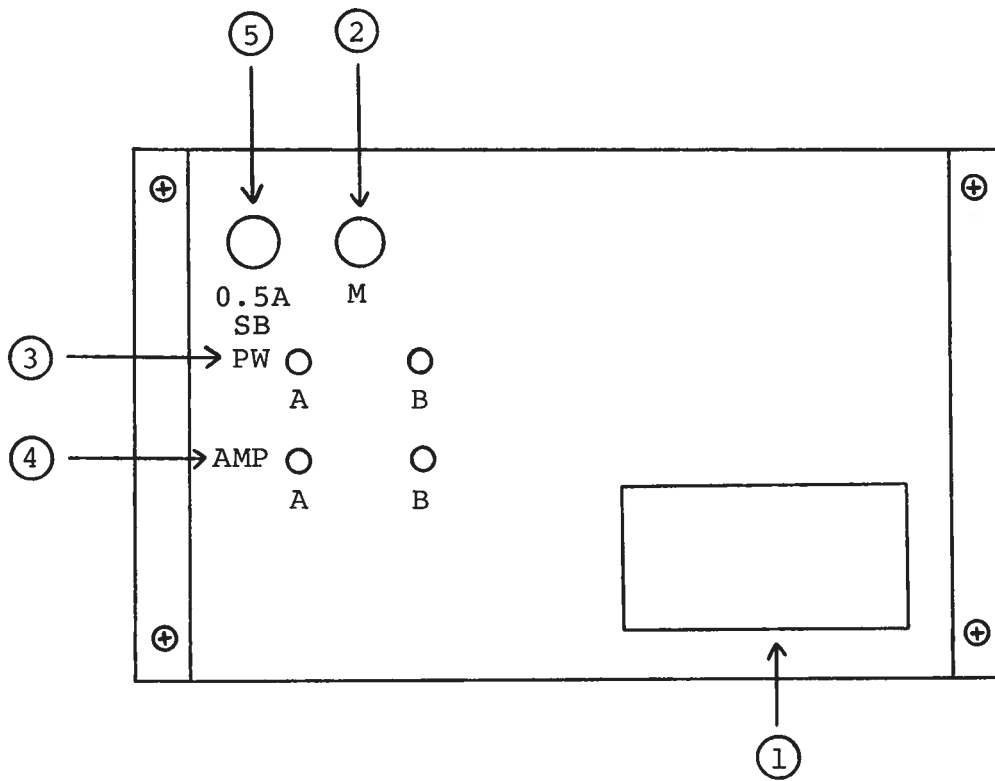

- (1) FUSED CONNECTOR, VOLTAGE SELECTOR. The detachable power cord is connected at this point. In addition, the removable cord is adjusted to select the desired input operating voltage. The unit also contains the main power fuse.
- (2) MONITOR Output (M). Output voltage (to fifty ohms) at this point (V_M) can be related to AV0-5B-T output current (I_{OUT}) as follows (option):

$$I_{OUT} = 3.2 V_M \quad (\text{Volts and Amps})$$

- (3) To voltage control the output pulse width, remove the jumper wire between banana plugs A and B and apply 0 to +10V to connector B ($R_{IN} \gg 10K$). (option).
- (4) To voltage control the output amplitude, remove the jumper wire between banana plugs A and B and apply 0 to +10V to connector B ($R_{IN} \gg 10K$). (option).
- (5) 0.5A SB. This fuse limits the DC prime power supplied to the output stage and will blow in the case of severe overloading. Do not exceed the duty cycle limits described in paragraph 12 of the general operating instructions.

Fig. 4

SYSTEM BLOCK DIAGRAM

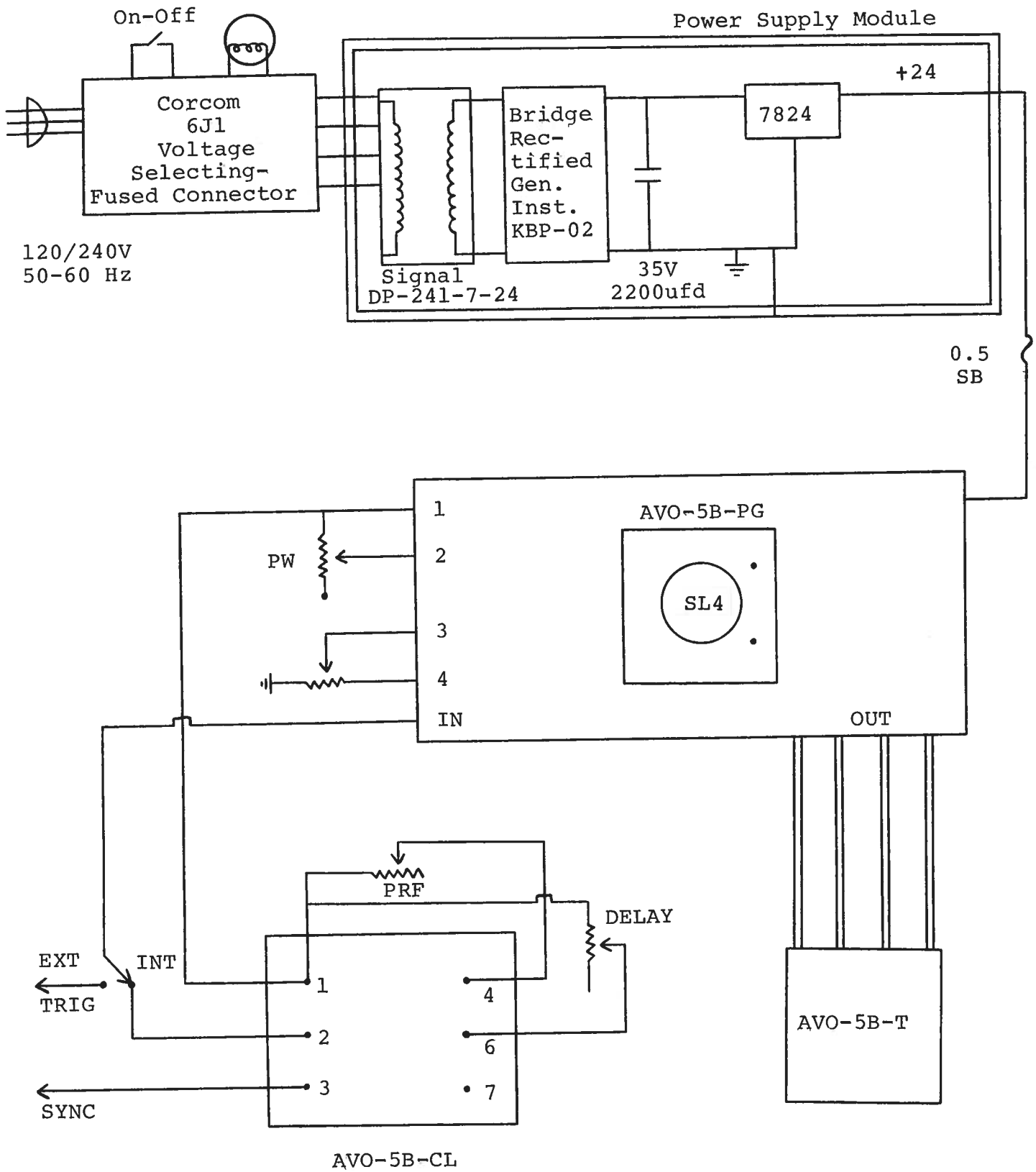

SYSTEM DESCRIPTION AND REPAIR PROCEDURE

The AVO-5B-C unit consists of the following basic modules:

- 1) AVO-5B-PG pulse generator module
- 2) AVO-5B-CL clock module
- 3) +24V power supply board

The modules are interconnected as shown in Fig. 4. The clock module controls the output PRF and the relative delay between the main output and the SYNC outputs. The PG pulse generator module generates the output pulse. In the event of an instrument malfunction, it is most likely that the rear panel 0.5A SB fuse or some of the output switching elements (SL4) may have failed due to an output short circuit condition or to a high duty cycle condition. The switching elements may be accessed by removing the cover plate on the bottom side of the instrument. NOTE: First turn off the prime power. The elements may be removed from their sockets by means of a needle nosed pliers. The SL4 is a selected VMOS power transistor in a TO 220 packages and may be checked on a curve tracer. If defective, replacement units should be ordered directly from Avtech. When replacing the SL4 switching elements, take care to insure that the short lead (of the three leads) is adjacent to the black dot on the chassis. If the switching elements are not defective, then the four Phillips screws on the back panel should be removed. The top cover may then be slid off and the operation of the clock and power supply modules checked. The clock module is functioning properly if:

- a) 0.1 usec TTL level outputs are observed at pins 2 and 3.
- b) The PRF of the outputs can be varied over the range of 0.1 KHz to 1.0 KHz using the PRF and PRF FINE controls.
- c) The relative delay between the pin 2 and 3 outputs can be varied by at least 200 nsec by the DELAY control.

The sealed clock module must be returned to Avtech for repair or replacement if the above conditions are not observed. The power supply board generates +24V DC to power the other modules. If the voltage is less than +24V, turn off the prime power and unsolder the lead from the 7824 regulator chip on the power supply board. Solder a 100 ohm 5 watt resistor to the 7824 output to ground and turn on the prime power. A voltage of +24 volts should be read. If the voltage is less then the power supply board is defective and should be repaired or replaced.

Schroff 04.26.89 Edition A

- EW
- EA
- M