

# AVTECH ELECTROSYSTEMS LTD.

NANOSECOND WAVEFORM ELECTRONICS  
ENGINEERING - MANUFACTURING

□ P.O. BOX 265  
OGDENSBURG  
NEW YORK  
13669  
(315) 472-5270

☒ BOX 5120, STN. "F"  
OTTAWA, ONTARIO  
CANADA K2C 3H4  
TEL: (613) 226-5772  
FAX: (613) 226-2802  
TELEX: 053-4591

## INSTRUCTIONS

MODEL AVO-5B-C-FN-FWSC (MOD) PULSE GENERATOR

S.N.: 5171 (MOD)

## WARRANTY

Avtech Electrosystems Ltd. warrants products of its manufacture to be free from defects in material and workmanship under conditions of normal use. If, within one year after delivery to the original owner, and after prepaid return by the original owner, this Avtech product is found to be defective, Avtech shall at its option repair or replace said defective item. This warranty does not apply to units which have been disassembled, modified or subjected to conditions exceeding the applicable specifications or ratings. This warranty is the extent of the obligation or liability assumed by Avtech with respect to this product and no other warranty or guarantee is either expressed or implied.

Fig. 1

PULSE GENERATOR TEST ARRANGEMENT

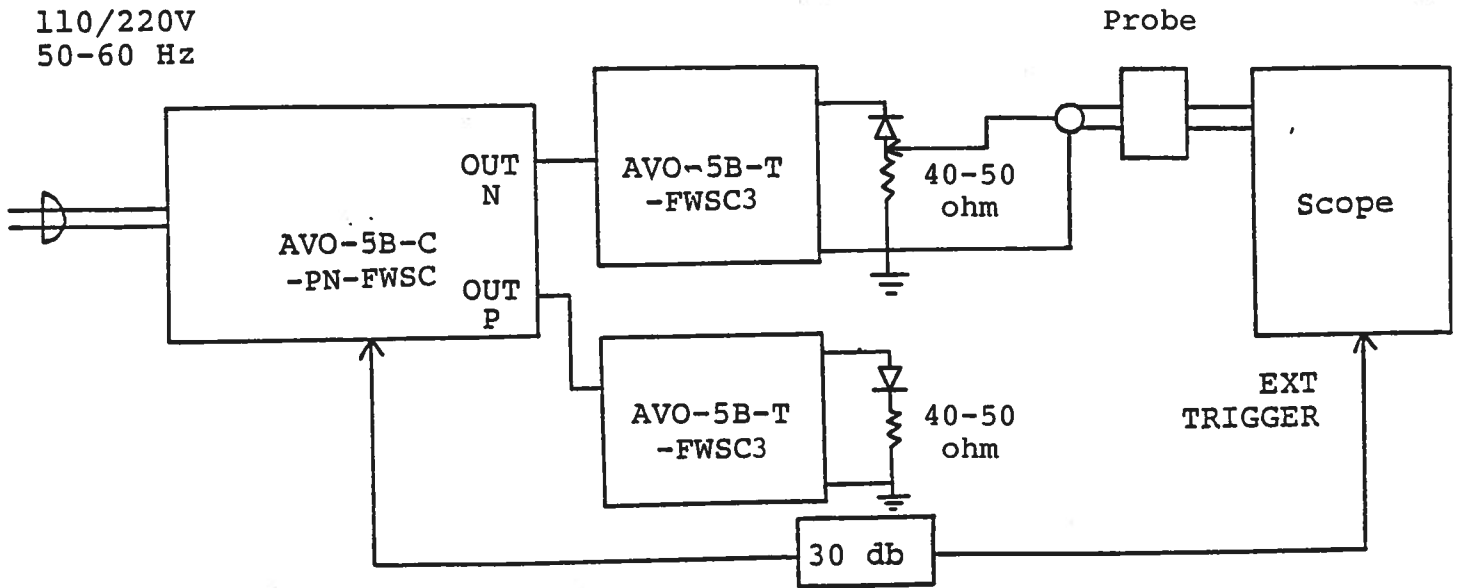

Notes:

- 1) The equipment should be connected in the general fashion shown above. Since the AVO unit provides an output pulse rise time as low as 10 nsec a fast oscilloscope (at least 50 MHz and preferably 200 MHz) should be used to display the waveform. If a sampling scope is used, a 50 db (or greater) attenuator should be used to insure a peak input to the scope of less than 0.5 volts.
- 2) The sync output channel provides TTL level signals. To avoid overdriving the TRIG input channel of some sampling scopes, a 30 db attenuator should be placed at the input to the sampling scope trigger channel.
- 3) The desired output polarity is selected by means of the front panel POLARITY switch. With the POLARITY switch in the P position, the negative output pulse generator is rendered inactive. Likewise, with the POLARITY switch in the N position, the positive pulse generator is rendered inactive.
- 4) To obtain a stable output display the PRF control on the front panel should be set mid-range. The front panel TRIG toggle switch should be in the INT position. The front panel DELAY control and the scope triggering controls are then adjusted to obtain a stable output. The scope may then be used to set the desired PRF by rotating the PRF control. The main output is delayed with respect to the SYNC output by about 0 to 200 nsec depending on the DELAY control setting. **CAUTION:** The output duty cycle must not exceed 0.5% (eg. PRF  $\leq$  10 KHz at PW = 500 nsec).
- 5) The AVO-5B-T-FWSC3 module connects to the mainframe via a 50 ohm miniature coaxial cable approx. 3 feet in length. The output terminals of the transformer module consists of a short length of microstrip transmission line protruding from the module chassis. The OUT terminal is the center conductor which is bounded on both sides by the ground plane (see below):

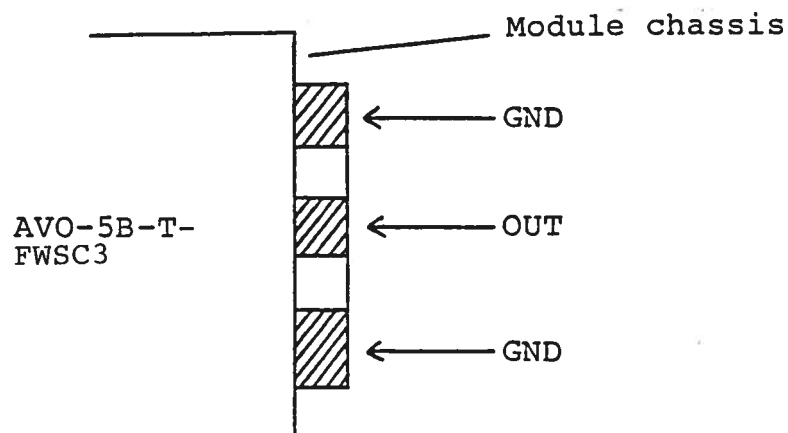

The diode load and series resistor (40-50 ohm 2 W carbon composition resistor) should be connected between the OUT and GND terminals using very short leads ( $\ll 0.5$  cm). The voltage across the resistor may be monitored using a high impedance pulse.

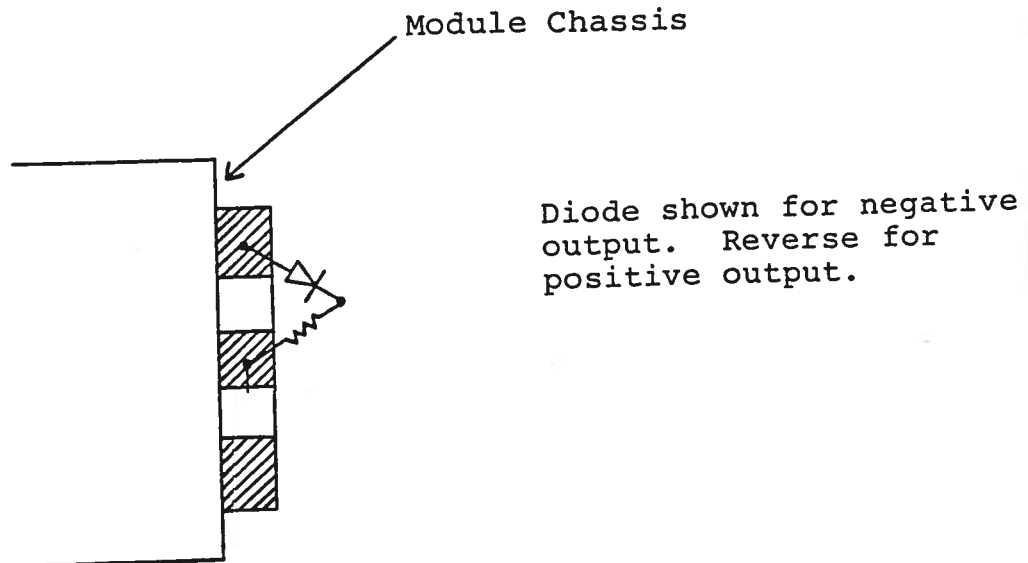

Take care to insure that during soldering the OUT conductor is not shorted to the chassis. Also, use minimal heat when soldering.

- 6) The output pulse widths for the positive and negative outputs are controlled by means of the front panel one turn PW control. To voltage control the pulse width, set the rear panel switch in the EXT position and apply 0 to +10 volts between terminal A and ground ( $R_{IN} > 10K$ ). The pulse width is controlled digitally and consequently small jumps or steps in pulse width may be visible as the pulse width knob is adjusted. For some settings of the knob, the falling edge of the pulse may jitter between steps. This jitter may be removed either by a slight adjustment to the pulse width control knob or by setting the rear panel PW LATCH switch in the ON position. Note that with the LATCH switch in the ON position, the front panel PW control knob is disabled.
- 7) The output pulse amplitudes for the positive and negative outputs are controlled by means of the front panel one turn AMP control. To voltage control the output, set the rear panel switch in the EXT position and apply 0 to +10 volts between terminal A and ground ( $R_{IN} > 10K$ ).

- 8) The output PRF is controlled by means of the front panel one turn PRF control. To voltage control the PRF, set the rear panel switch in the EXT position and apply 0 to +10 volts between terminal A and ground ( $R_{IN} > 10K$ ).
- 9) The output rise and fall time are controlled by the front panel RISE TIME one turn control and by a two position switch (on each PG module) located in the interior of the instrument. The control ranges are as follows:

INTERIOR SWITCH POSITION	RISE TIME CONTROL KNOB RANGE
L	10 to 20 ns
H	20 to 40 ns

The unit was shipped with the interior switch in the H position.

- 10) CAUTION: The rear panel 1.0A SB fuse may blow if the output duty cycle exceeds 0.5% (eg. PRF  $\ll$  10 KHz for PW = 500 nsec).

Fig. 2

FRONT PANEL CONTROLS

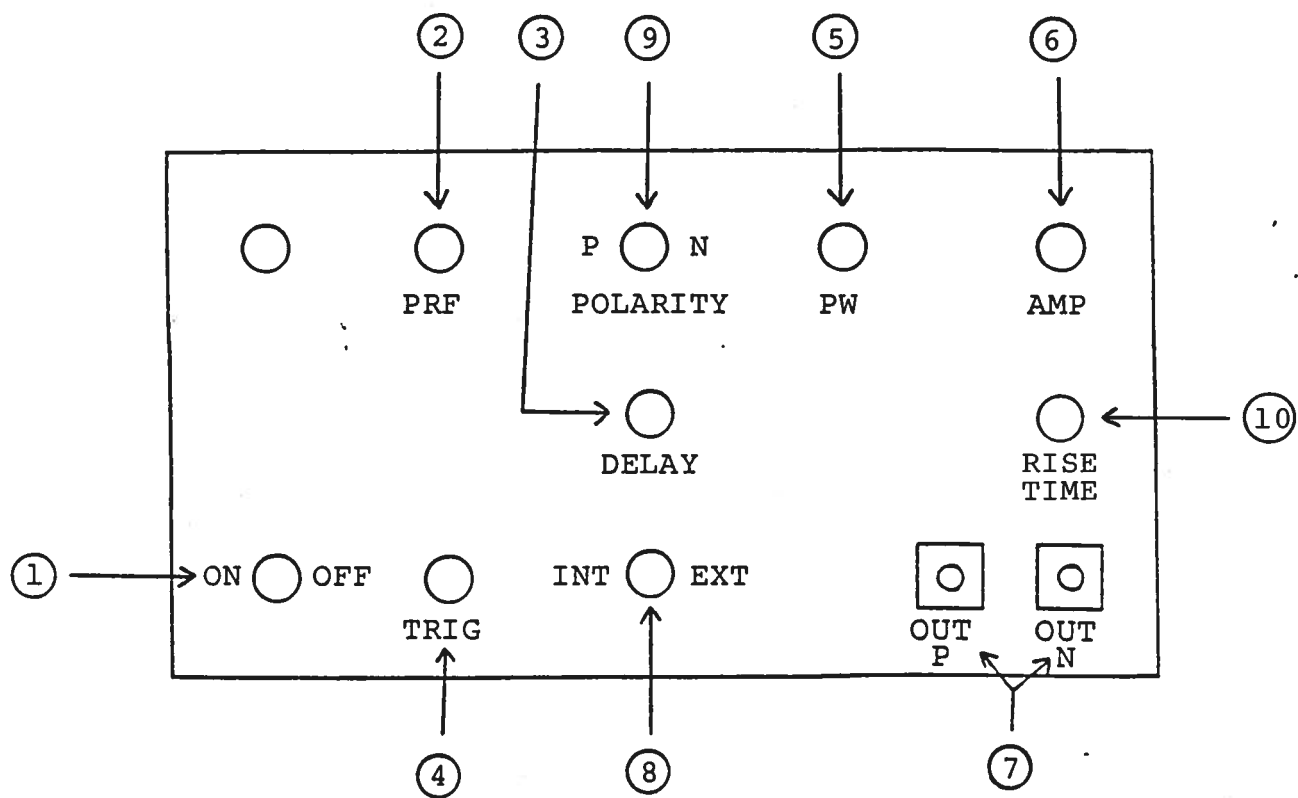

- (1) ON-OFF Switch. Applies basic prime power to all stages.
- (2) PRF Control. Varies PRF from about 200 Hz to about 20 KHz. The operating PRF should be set using a scope.
- (3) DELAY Control. Controls the relative delay between the reference output pulse provided at the SYNC output (4) and the main output (7). This delay is variable over the range of about 0 to 200 nsec.
- (4) TRIG. This output precedes the main output (7) and is used to trigger the sampling scope time base. The output is a TTL level 100 nsec (approx) pulse capable of driving a fifty ohm load. The external trigger signal is applied at this input when the EXT-INT toggle switch (8) is in the EXT position. The output pulse at (7) appears about 60 nsec after the application of the TRIG pulse.
- (5) PW Control. A one turn control which varies the output pulse width from 25 to 500 nsec.
- (6) AMP Control. The output pulse amplitude is controlled by means of the one turn potentiometer (AMP).
- (7) OUT Connectors. SMA connectors for miniature coaxial cables connected to the AVO-5B-T module (positive and negative outputs).
- (8) EXT-INT Control. With this toggle switch in the INT position, the PRF of the AVO unit is controlled via an internal clock which in turn is controlled by the PRF and PRF FINE controls. With the toggle switch in the EXT position, the AVO unit requires a 0.2 usec TTL level pulse applied at the TRIG input in order to trigger the output stages. In addition, in this mode, the scope time base must be triggered by the external trigger source.
- (9) POLARITY Control. With the switch in the P position, the negative output pulse generator is rendered inactive. With the switch in the N position, the positive output pulse generator is rendered inactive.
- (10) RISE TIME. The output rise and fall time are controlled by the front panel RISE TIME one turn control and by a two position switch (on each PG module) located in the interior of the instrument. The control ranges are as follows:



INTERIOR SWITCH  
POSITION

RISE TIME CONTROL  
KNOB RANGE

L

10 to 20 ns

H

20 to 40 ns

The unit was shipped with the interior switch in the H position.

Fig. 3

BACK PANEL CONTROLS

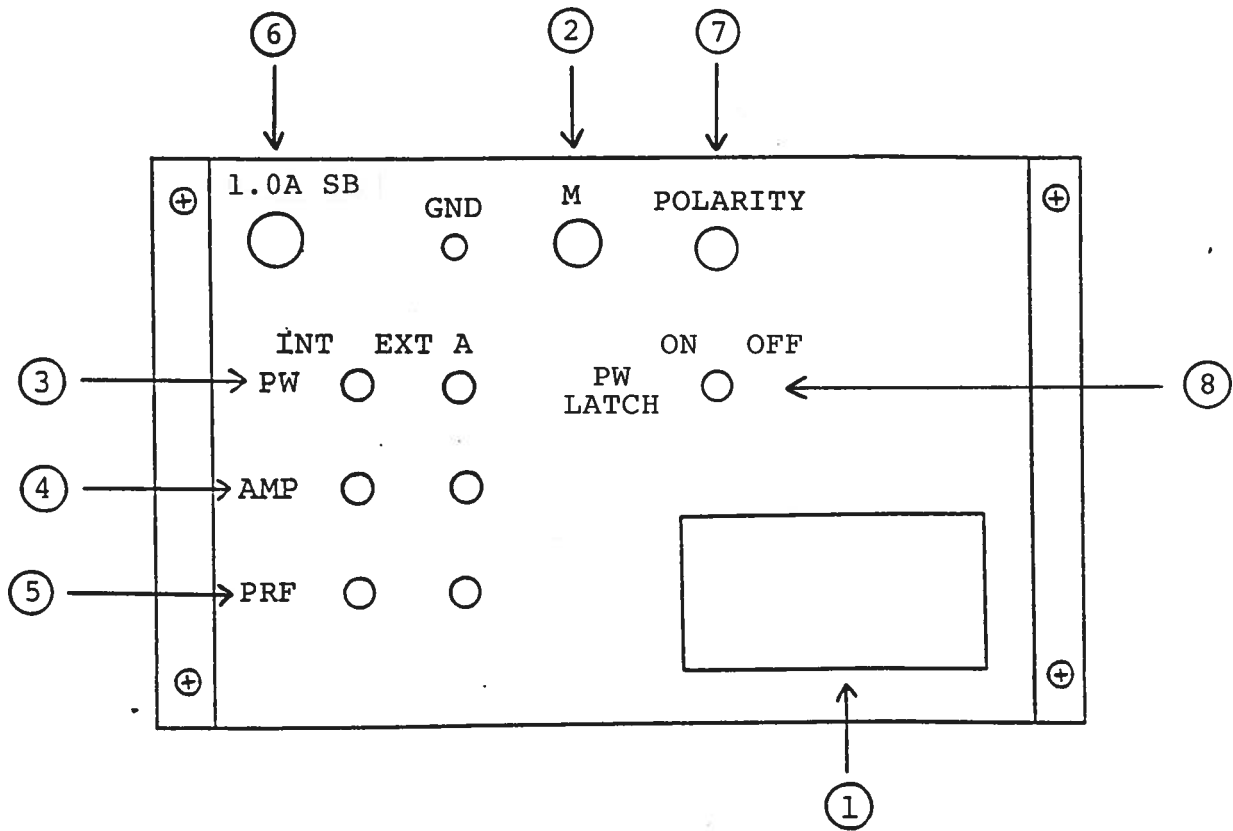

(1) FUSED CONNECTOR, VOLTAGE SELECTOR. The detachable power cord is connected at this point. In addition, the removable cord is adjusted to select the desired input operating voltage. The unit also contains the main power fuse.

(2) MONITOR Output (M). Output voltage (to fifty ohms) at this point ( $V_M$ ) can be related to AVO-5B-T-FWSC3 output voltage ( $V_{OUT}$ ) as follows (option):

$$V_{OUT} = 10 V_M \quad (\text{Volts})$$

(3) EA. To voltage control the output amplitude, set the switch in the EXT position and apply 0 to +10 volts between terminal A and ground ( $R_{IN} > 10K$ ). (option).

(4) EW. To voltage control the output pulse width, set the switch in the EXT position and apply 0 to +10 volts between terminal A and ground ( $R_{IN} > 10K$ ). (option).

(5) EF. To voltage control the output PRF, set the switch in the EXT position and apply 0 to +10 volts between terminal A and ground ( $R_{IN} > 10K$ ). (option).

(6) 1.0 SB. Fuse which protects the output stage if the output duty cycle rating is exceeded.

(7) POLARITY. This terminal is at +5 volts DC ( $R_L \geq 10K$ ) if the pulse generator output is positive and at 0 volts if the output is negative ( $R_{OUT} \approx 200$  ohm).

(8) PW LATCH. The pulse width is controlled digitally and consequently small jumps or steps in pulse width may be visible as the pulse width knob is adjusted. For some settings of the knob, the falling edge of the pulse may jitter between steps. This jitter may be removed either by a slight adjustment to the pulse width control knob or by setting the rear panel PW LATCH switch in the ON position. Note that with the LATCH switch in the ON position, the front panel PW control knob is disabled.

Fig. 4

SYSTEM BLOCK DIAGRAM

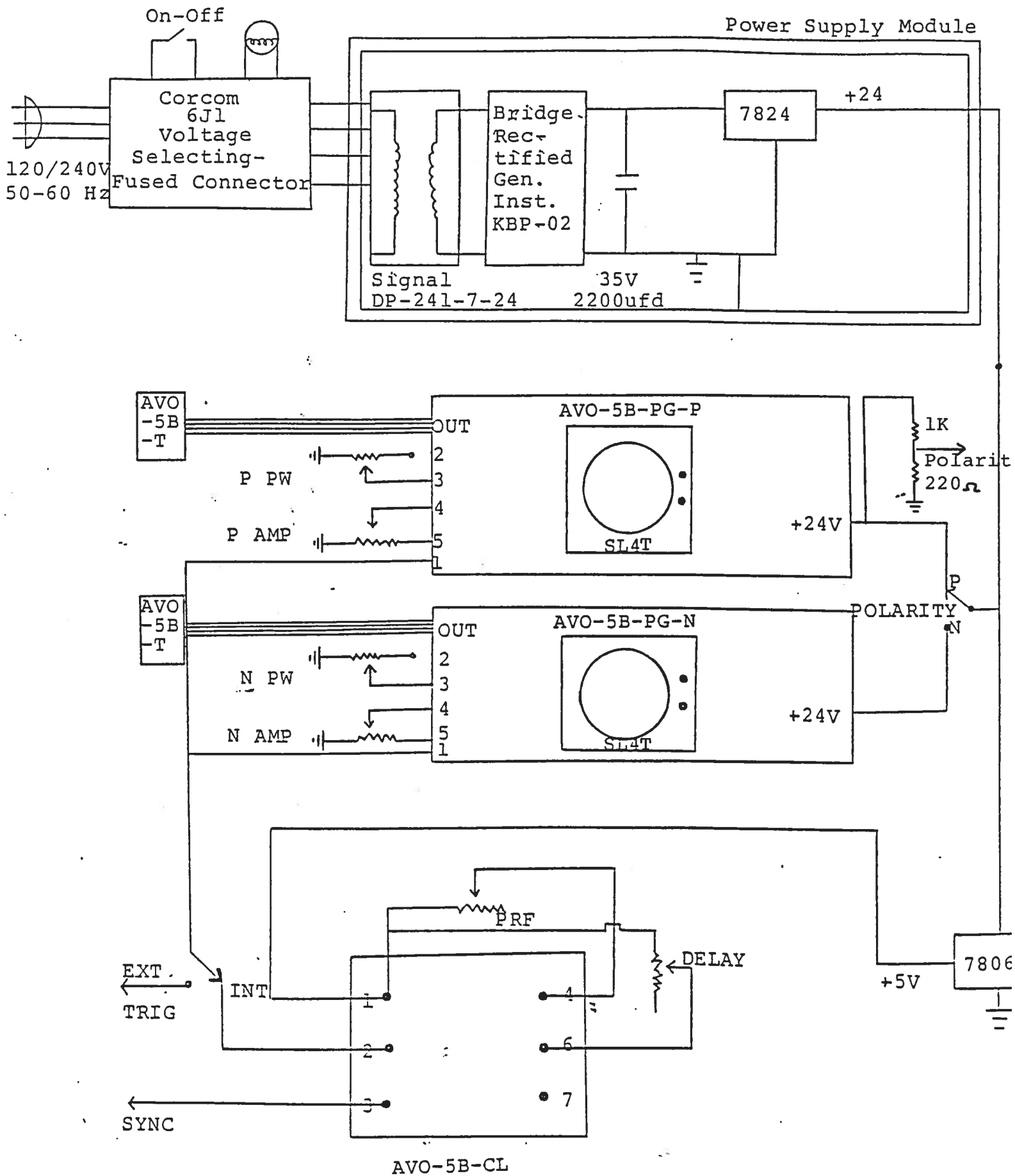

## SYSTEM DESCRIPTION AND REPAIR PROCEDURE

The AVO-5B-C-PN unit consists of the following basic modules:

- 1) AVO-5B-PG pulse generator module (positive and negative)
- 2) AVO-5B-CL clock module
- 3) +24V power supply board

The modules are interconnected as shown in Fig. 4. The clock module controls the output PRF and the relative delay between the main output and the SYNC outputs. The PG pulse generator module generates the output pulse. In the event of an instrument malfunction, it is most likely that the rear panel 0.5A SB fuse or some of the output switching elements (SL4T) may have failed due to an output short circuit condition or to a high duty cycle condition. The switching elements may be accessed by removing the cover plate on the bottom side of the instrument. NOTE: First turn off the prime power. The elements may be removed from their sockets by means of a needle nosed pliers. The SL4T is a selected VMOS power transistor in a TO 220 packages and may be checked on a curve tracer. If defective, replacement units should be ordered directly from Avtech. When replacing the SL4T switching elements, take care to insure that the short lead (of the three leads) is adjacent to the black dot on the chassis. If the switching elements are not defective, then the four Phillips screws on the back panel should be removed. The top cover may then be slid off and the operation of the clock and power supply modules checked. The clock module is functioning properly if:

- a) 0.1 usec TTL level outputs are observed at pins 2 and 3.
- b) The PRF of the outputs can be varied over the range of 200 Hz to 20.0 KHz using the PRF and PRF FINE controls.
- c) The relative delay between the pin 2 and 3 outputs can be varied by at least 200 nsec by the DELAY control.

The sealed clock module must be returned to Avtech for repair or replacement if the above conditions are not observed. The power supply board generates +24V DC to power the other modules. If the voltage is less than +24V, turn off the prime power and unsolder the lead from the 7824 regulator chip on the power supply board. Solder a 100 ohm 5 watt resistor to the 7824 output to ground and turn on the prime power. A voltage of +24 volts should be read. If the voltage is less then the power supply board is defective and should be repaired or replaced.

Schroff

01.23.91

-EW

-EA

-EF

-M