



AVTECH ELECTROSYSTEMS LTD.

NANOSECOND WAVEFORM ELECTRONICS
SINCE 1975

P.O. BOX 265
OGDENSBURG, NY
U.S.A. 13669-0265
TEL: (315) 472-5270
FAX: (613) 226-2802

TEL: 1-800-265-6681
FAX: 1-800-561-1970

e-mail: info@avtechpulse.com
<http://www.avtechpulse.com>

P.O. BOX 5120 STN. F
OTTAWA, ONTARIO
CANADA K2C 3H4
TEL: (613) 226-5772
FAX: (613) 226-2802

INSTRUCTIONS

MODEL AVO-6A-N-PS-PTA PULSE GENERATOR

S.N.:

WARRANTY

Avtech Electrosystems Ltd. warrants products of its manufacture to be free from defects in material and workmanship under conditions of normal use. If, within one year after delivery to the original owner, and after prepaid return by the original owner, this Avtech product is found to be defective, Avtech shall at its option repair or replace said defective item. This warranty does not apply to units which have been disassembled, modified or subjected to conditions exceeding the applicable specifications or ratings. This warranty is the extent of the obligation assumed by Avtech with respect to this product and no other warranty or guarantee is either expressed or implied.

TECHNICAL SUPPORT

Phone: 613-226-5772 or 1-800-265-6681

Fax: 613-226-2802 or 1-800-561-1970

E-mail: info@avtechpulse.com

World Wide Web: <http://www.avtechpulse.com>

TABLE OF CONTENTS

WARRANTY	2
TABLE OF CONTENTS	3
GENERAL OPERATING INSTRUCTIONS	5
GENERAL INSTRUCTIONS	7
BACK PANEL CONTROLS	10
SYSTEM DESCRIPTION AND REPAIR PROCEDURE.....	12

FIG 1: TEST ARRANGEMENT

(without AVX-S1 module)

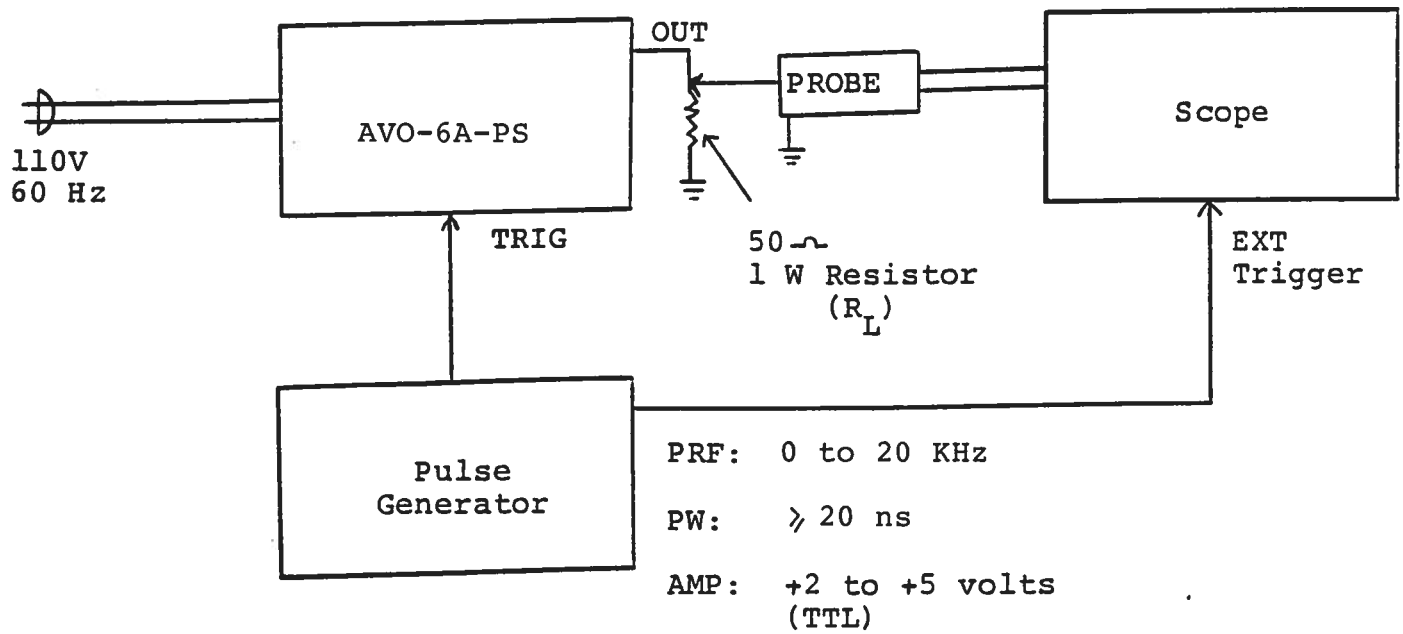

GENERAL OPERATING INSTRUCTIONS

- 1) The equipment should be connected in the general fashion shown above. Since the AVR unit provides an output pulse rise time as low as 5 ns, a fast oscilloscope (at least 50 MHz and preferably 200 MHz) should be used to display the waveform.
- 2) The output PRF is equal to the input trigger pulse PRF.
- 3) The output pulse width is controlled (from 50 to 500 ns) by the front panel ten turn PW control.
- 4) The output pulse amplitude is controlled (from 0 to -50 Volts) by means of the front panel ten turn AMP control.
- 5) The propagation delay is controlled (from 50 to 500 ns) by the front panel ten turn delay control.
- 6) This unit is protected by an automatic overload protective protective circuit which controls the front panel overload light. If the unit is overloaded (by operating at an exceedingly high duty cycle), the protective circuit will turn the output of the instrument OFF and turn the indicator light ON. The light will stay ON (i.e. output OFF) for about 5 seconds after which the instrument will attempt to turn ON (i.e. light OFF) for about 1 second. If the overload condition persists, the instrument will turn OFF again (i.e. light ON) for another 5 seconds. If the overload condition has been removed, the instrument will turn on and resume normal operation. Overload conditions may be removed by:
 - 1) Reducing PRF (i.e. switch to a lower range)
 - 2) Reducing pulse width (i.e. switch to a lower range)

Note that the overload light may come on when the prime power is applied. The light will extinguish after a few seconds and the unit will then function normally.

- 7) The unit can be converted from 110 to 220V 50-60 Hz operation by adjusting the voltage selector card in the rear panel fused voltage selector-cable connector assembly.
- 8) For additional assistance:

Tel: (613) 226-5772

Fax: (613) 226-2802

FIG 2: PULSE GENERATOR TEST ARRANGEMENT

(AVX-S1 MODULE CONNECTED)

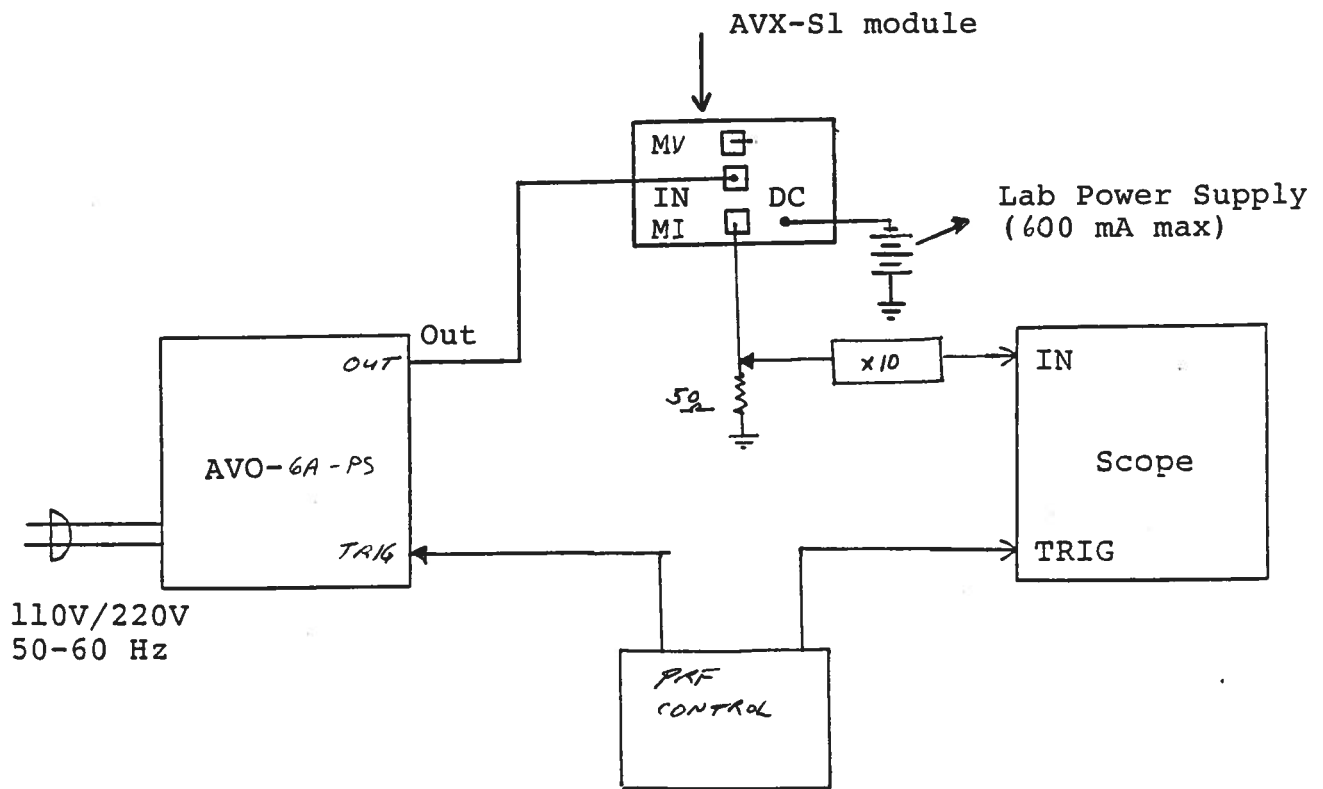

GENERAL INSTRUCTIONS

- (1) The AVX-S1 module should be connected to the AVO-6A-PS mainframe via the supplied 24" RG174 cable.
- (2) Gently insert the H1 package into the 8 pin socket assembly.
- (3) Connect the MI port to a scope set to 1 Volt/div and with a 50 Ohm load impedance.
- (4) The PINS on the D connector (AMP No. 57-60140) correspond to the PINS on the H1 package with the exception that PINS 4 (cathode) and 5 (anode) are not connected.
- (5) Connect a negative current source to the DC terminal. A lab power supply operating in the current limiting mode is recommended. The source must have a compliance voltage of at least -3 Volts. Slowly increase the offset current to -600 mA (as indicated by the meter on the lab power supply). To avoid transients when connecting the lab power supply, the voltage control knob should be fully CCW and the prime power should be ON. Slowly and cautiously increase the voltage and monitor the current control knob (and ammeter) to insure that the offset does not exceed 600 mA. Final control should be via the current knob.
- (6) The diode pulse current (Amps) and the voltage at M_I (Volts) are related as follows:

$$I_D = 0.22 V_{M_I}$$

AVX-S1 (SN 7659)

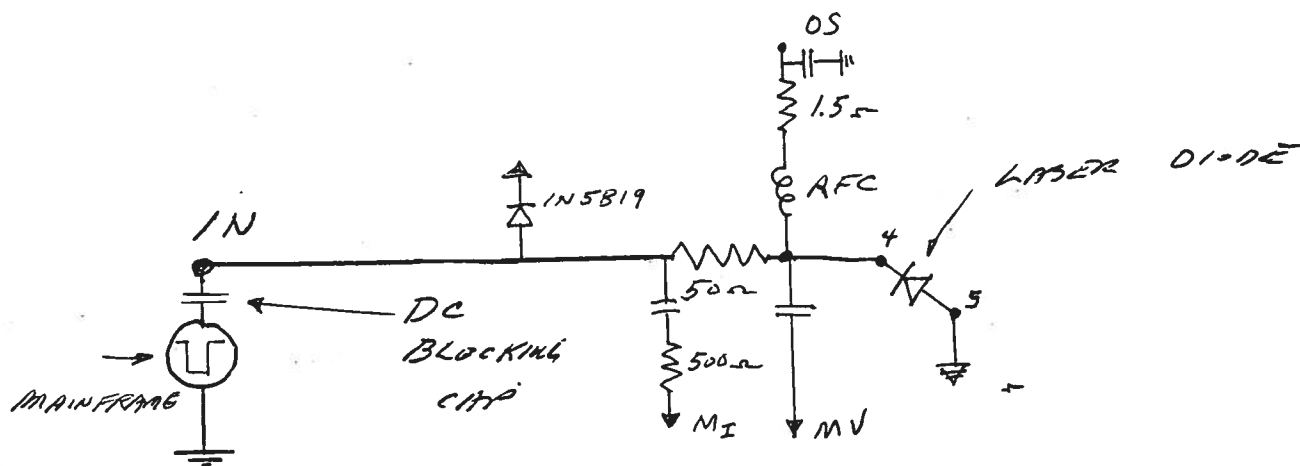

FUNCTIONAL EQUIV. CCT.

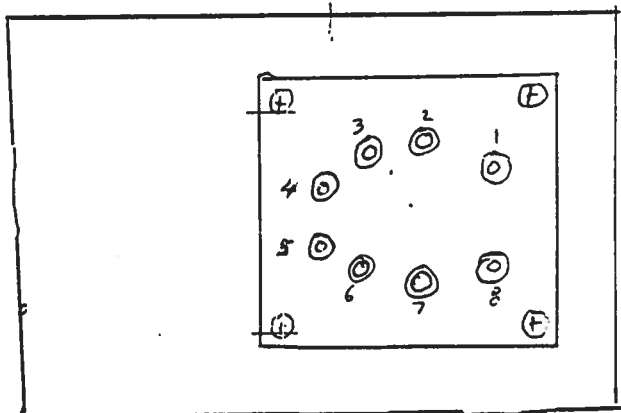
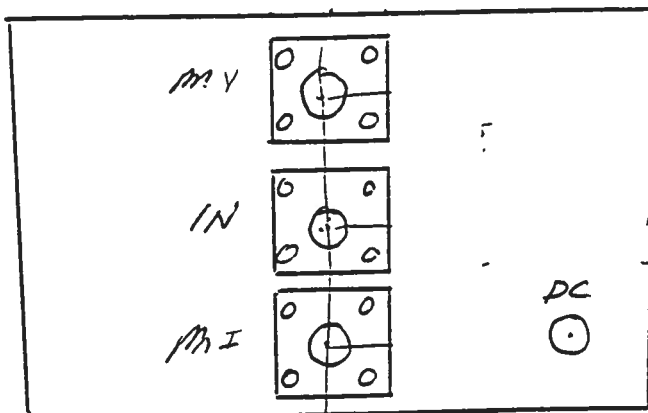

PACKAGE

FIG 3: BACK PANEL CONTROLS

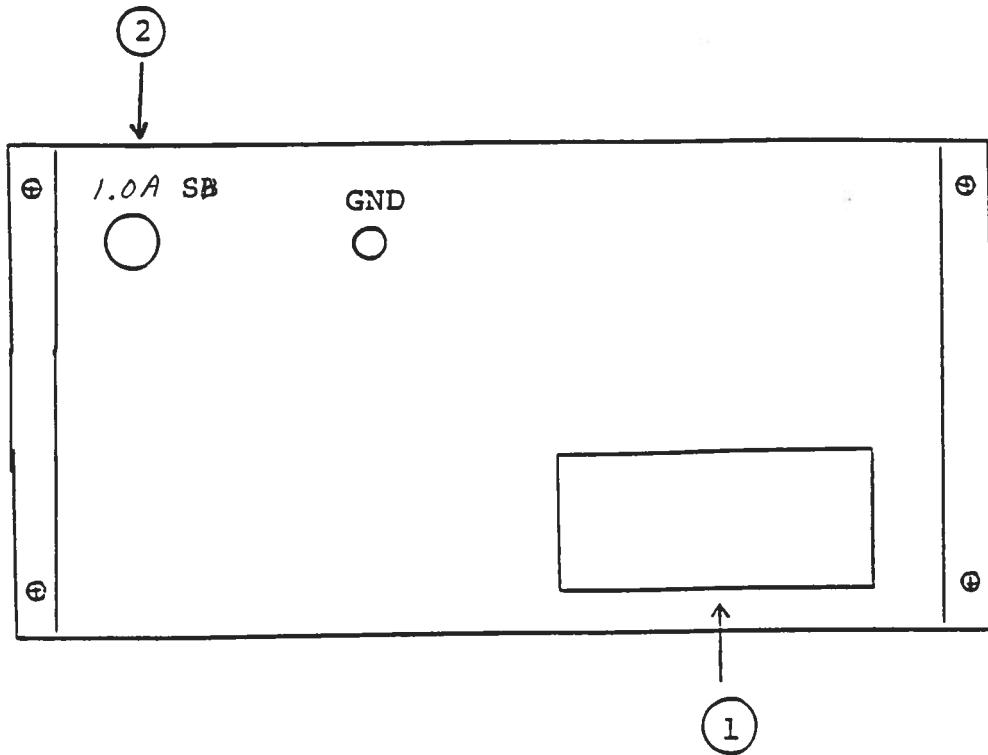

BACK PANEL CONTROLS

- (1) FUSED CONNECTOR, VOLTAGE SELECTOR. The detachable power cord is connected at this point. In addition, the removable cord is adjusted to select the desired input operating voltage. The unit also contains the main power fuse (0.5 SB).
- (2) 1.0 SB. Fuse which protects the output stage if the output duty cycle rating is exceeded.

FIG 4: SYSTEM BLOCK DIAGRAM AND REPAIR PROCEDURE

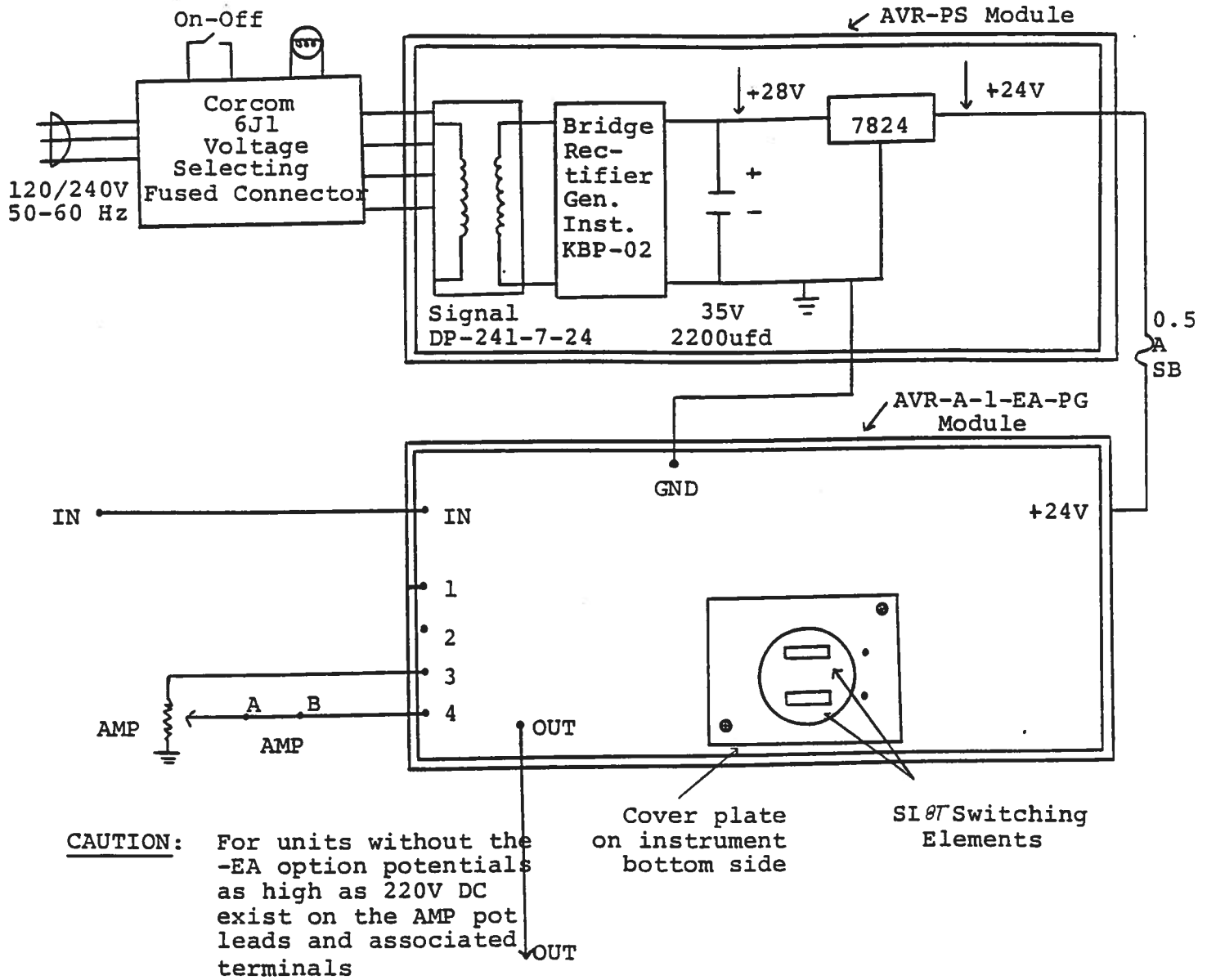

SYSTEM DESCRIPTION AND REPAIR PROCEDURE

- 1) The AVR unit consists of three basic components or modules:
 - a) Metal chassis
 - b) AVR-PS module (Power Supply)
 - c) AVR-PG module (Pulse Generator)
 - d) OL-471 overload module

The modules are interconnected as shown above.

- 2) If the unit malfunctions, first check the rear panel 1.0 SB fuse and then disconnect from the 60 Hz supply and the trigger source and remove the four Phillips screws on the top panel of the unit. With the screws removed, the top cover may be slid off.
- 3) Reconnect the 60 Hz source and check the voltage on the line connecting the -PS output to the +24 V pin of the -PG module. A voltage of +24 Volts should be recorded. If the voltage is substantially less than +24 Volts, disconnect the 60 Hz source and disconnect the line from the +24 Volt pin. Connect a 50 Ohm 8 Watt resistance to the output of the -PS module. Reconnect to the 60 Hz source and measure the voltage across the resistor. A voltage of +24 Volts should be indicated. If the voltage is substantially less than +24 Volts the -PS module is defective and should be either repaired or replaced. If the measured voltage is equal to +24 Volts then the SL8T switching elements in the -PG module have probably failed. The SL8T switching elements are easily replaced by removing the cover plate on the instrument bottom side and extracting the SL8T switching elements from their sockets using a pair of needle nose pliers. Before attempting this first insure that the prime power is off and also briefly ground the metal tabs on the SL8T elements to the chassis as the bypass capacitors may be charged to 60 Volts. Replacement SL8T units must be ordered directly from Avtech. When reinstalling the SL8T units in their sockets, insure that the shortest of the three terminals is adjacent to the black dot on the -PG chassis.

November 7/97

In word

File: c:\INSTRUCT\AV06\6APSPTA.DOC