

AVTECH ELECTROSYSTEMS LTD.

NANOSECOND WAVEFORM ELECTRONICS
ENGINEERING - MANUFACTURING

□ P.O. BOX 265
OGDENSBURG
NEW YORK
13669
(315) 472-5270

BOX 5120, STN. "F"
OTTAWA, ONTARIO
CANADA K2C 3H4
TEL: (613) 226-5772
FAX: (613) 226-2802
TELEX: 053-4591

INSTRUCTIONS

MODEL AVO-7-P-PS-SNL1-EA PULSE GENERATOR

S.N.:

WARRANTY

Avtech Electrosystems Ltd. warrants products of its manufacture to be free from defects in material and workmanship under conditions of normal use. If, within one year after delivery to the original owner, and after prepaid return by the original owner, this Avtech product is found to be defective, Avtech shall at its option repair or replace said defective item. This warranty does not apply to units which have been disassembled, modified or subjected to conditions exceeding the applicable specifications or ratings. This warranty is the extent of the obligation or liability assumed by Avtech with respect to this product and no other warranty or guarantee is either expressed or implied.

Fig. 1

PULSE GENERATOR TEST ARRANGEMENT

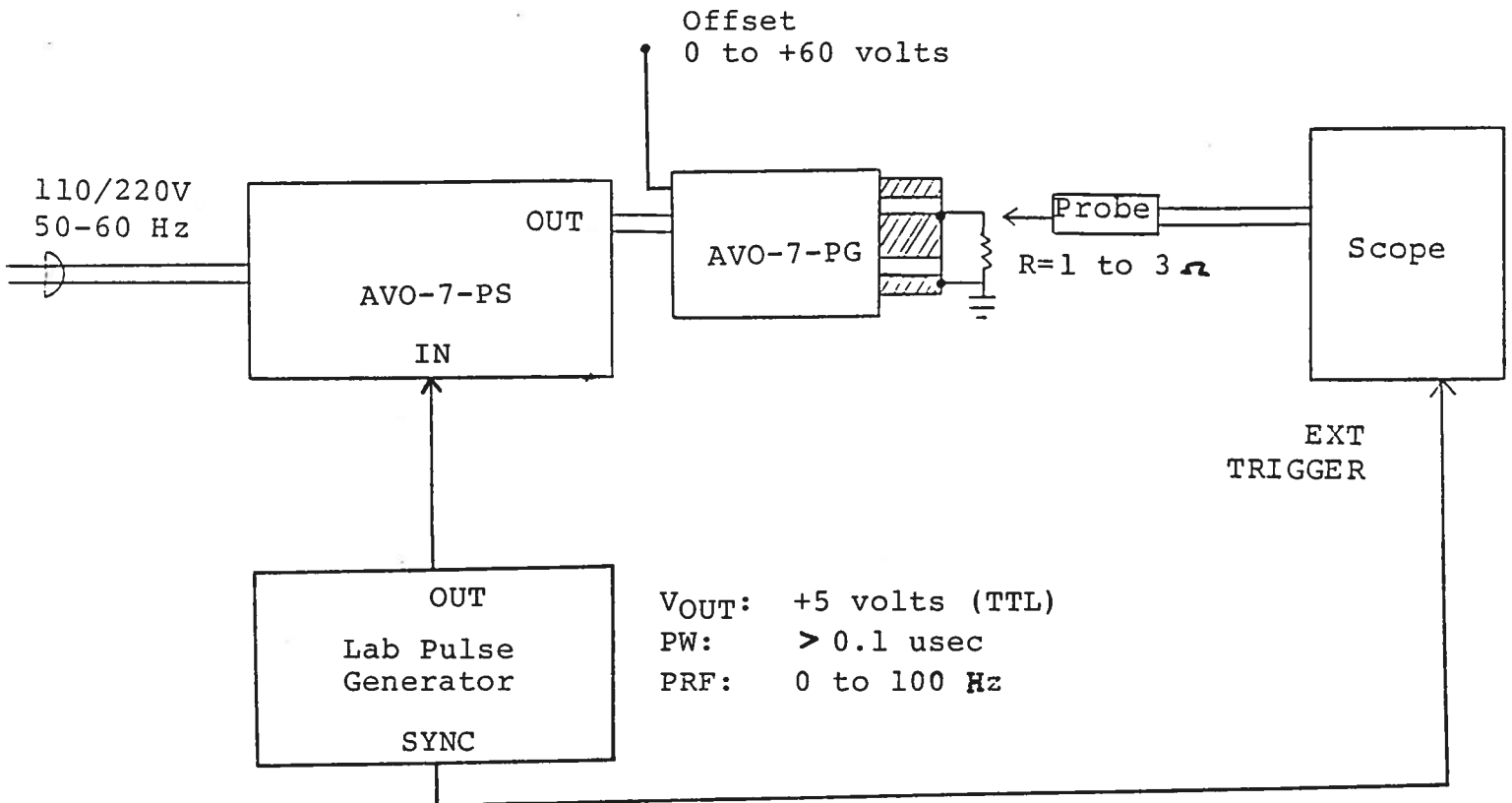

GENERAL OPERATING INSTRUCTIONS

- 1) The equipment should be connected in the general fashion shown above. Since the AVO unit provides an output pulse rise time as low as 100 nsec a fast oscilloscope (at least 50 MHz and preferably 200 MHz) should be used to display the waveform.
- 2) The output terminals of the pulse generator module consists of a short length of microstrip transmission line protruding from the module chassis. The OUT terminal is the center conductor which is bounded on both sides by the ground plane (see below):

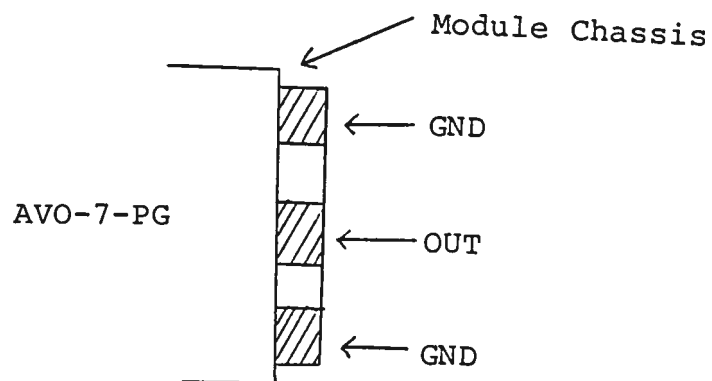

The load should be connected between the OUT and GND terminals using very short leads ($\ll 1.0$ cm). The voltage across the load may be monitored by means of a high impedance scope probe):

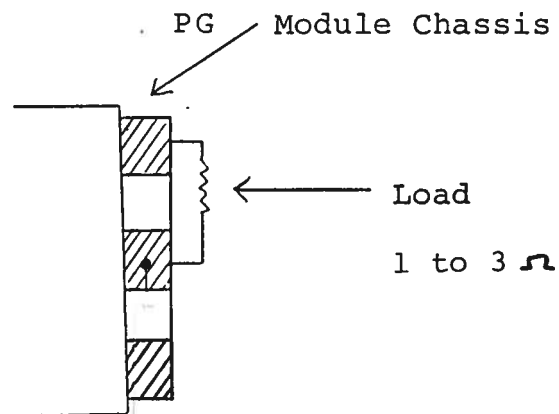

- 3) The output pulse width is controlled by the front panel one turn PW control.
- 4) The output voltage amplitude is controlled by the front panel one turn AMP control. CAUTION: The load current must not exceed 60 Amps (ie. for $R_L = 1 \Omega$, the output voltage must not exceed 60 volts while for $R_L = 3 \Omega$, the output voltage must not exceed 180 volts, see Fig. 1A).
- 5) To voltage control the output amplitude, remove the jumper wire between banana plugs A and B on the back panel and apply 0 to +10V to connector B ($R_{IN} \gg 10K$). (option). CAUTION: See CAUTION note in 4) above.

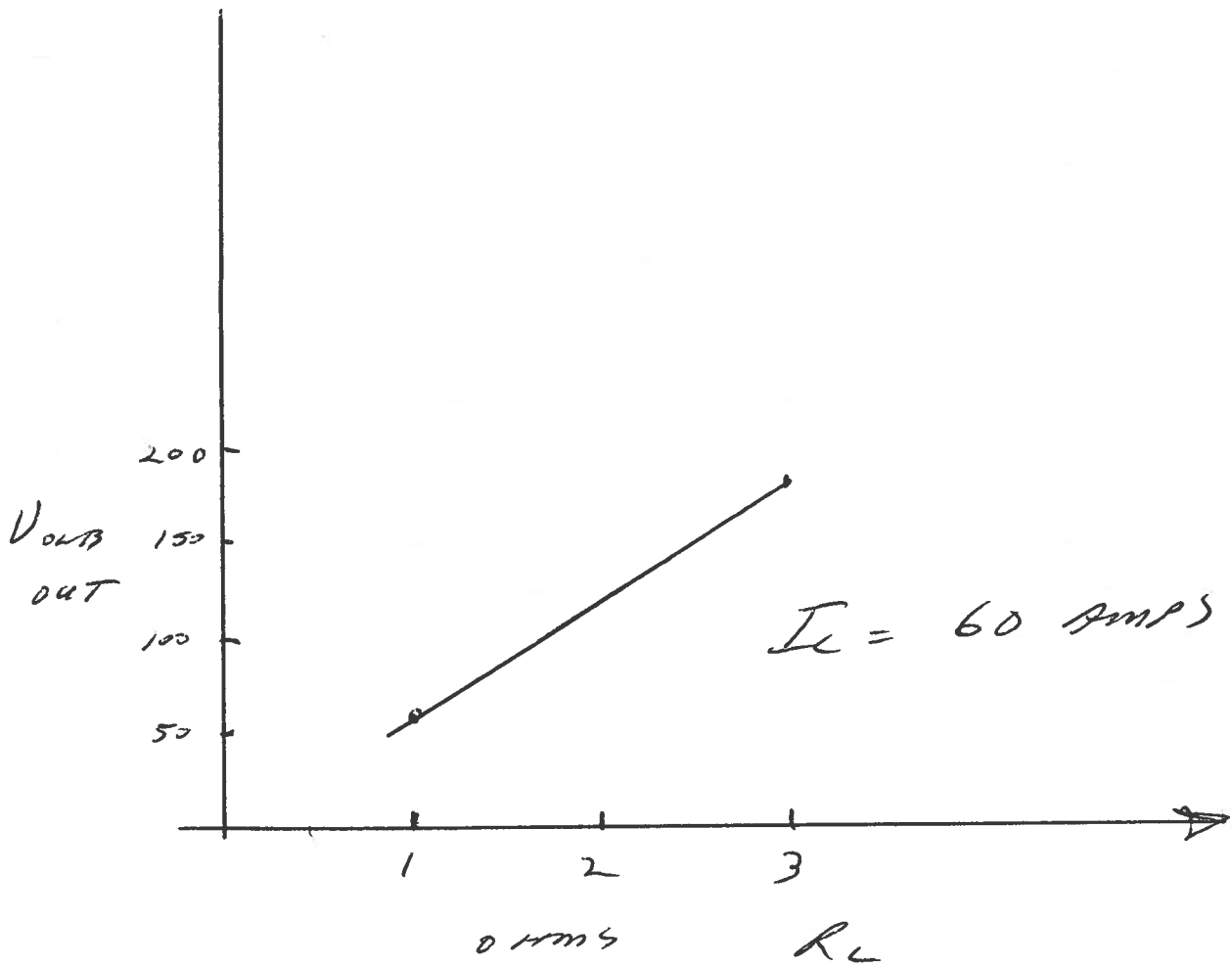
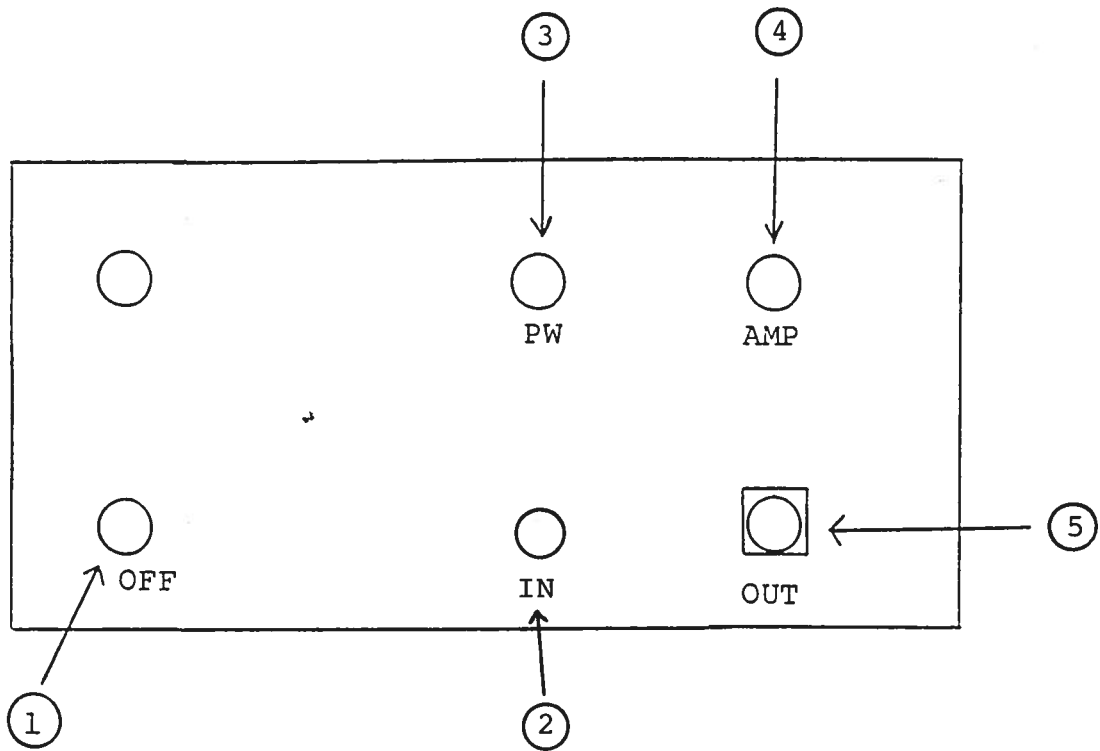

Fig 1A

MAX V_{out} VERSUS
LOAD RESISTANCE.

Fig. 2

FRONT PANEL CONTROLS



- (1) ON-OFF Switch. Applies basic prime power to all stages.
- (2) IN. The external trigger signal is applied at this input. (TTL, 5 volts, > 0.1 usec).
- (3) PW Control. A one turn control which varies the output pulse width from 1 to 5 usec.
- (4) AMP Control. The output pulse amplitude is controlled by means of the one turn potentiometer (AMP). CAUTION: Do not exceed load current limit of 60 Amps.
- (5) OUT Connector. A multi pin connector which attaches the 2 foot cable from the pulse generator module to the main frame.

Fig. 3

BACK PANEL CONTROLS

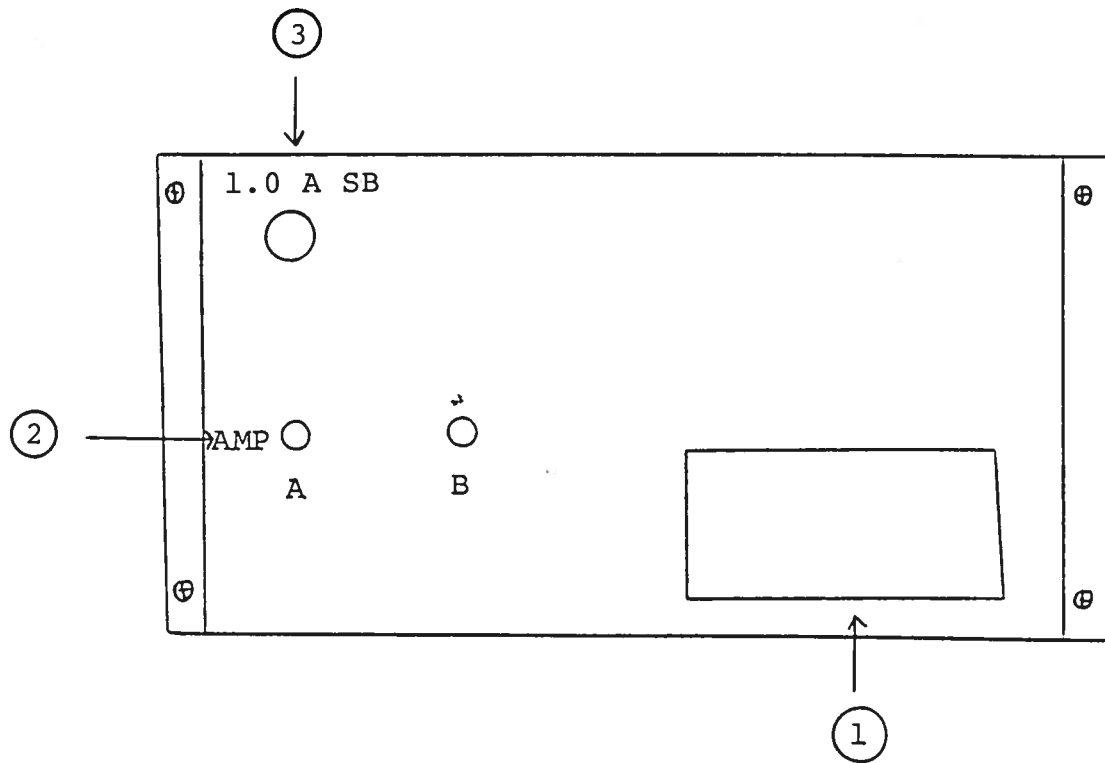

- (1) FUSED CONNECTOR, VOLTAGE SELECTOR. The detachable power cord is connected at this point. In addition, the removable cord is adjusted to select the desired input operating voltage. The unit also contains the main power fuse.
- (2) To voltage control the output amplitude, remove the jumper wire between banana plugs A and B and apply 0 to +10V to connector B ($R_{IN} \geq 10K$). (option).
- (3) 1.0 A SB FUSE. Protects output stage against overload conditions.

Fig. 4

SYSTEM BLOCK DIAGRAM (-P ONLY)

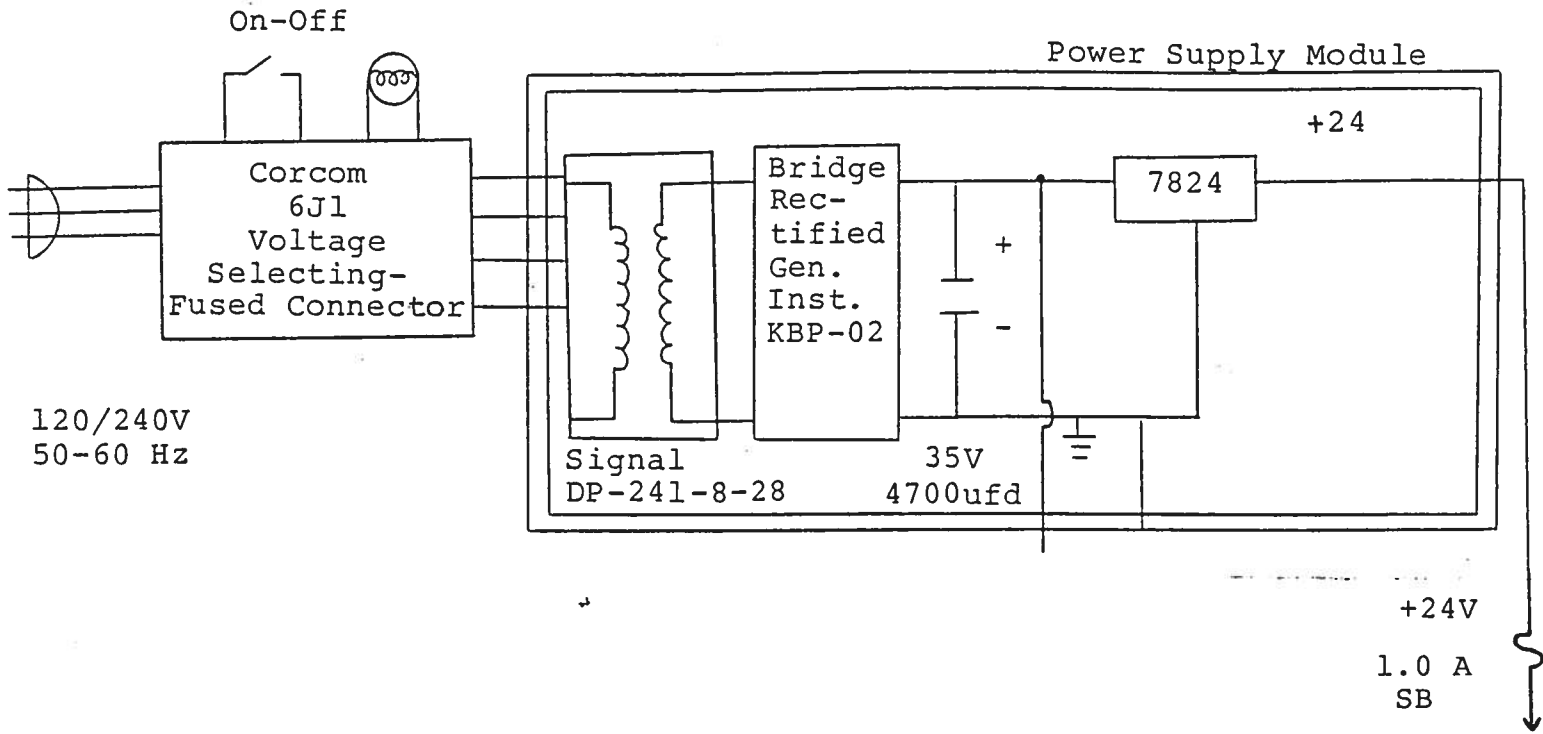

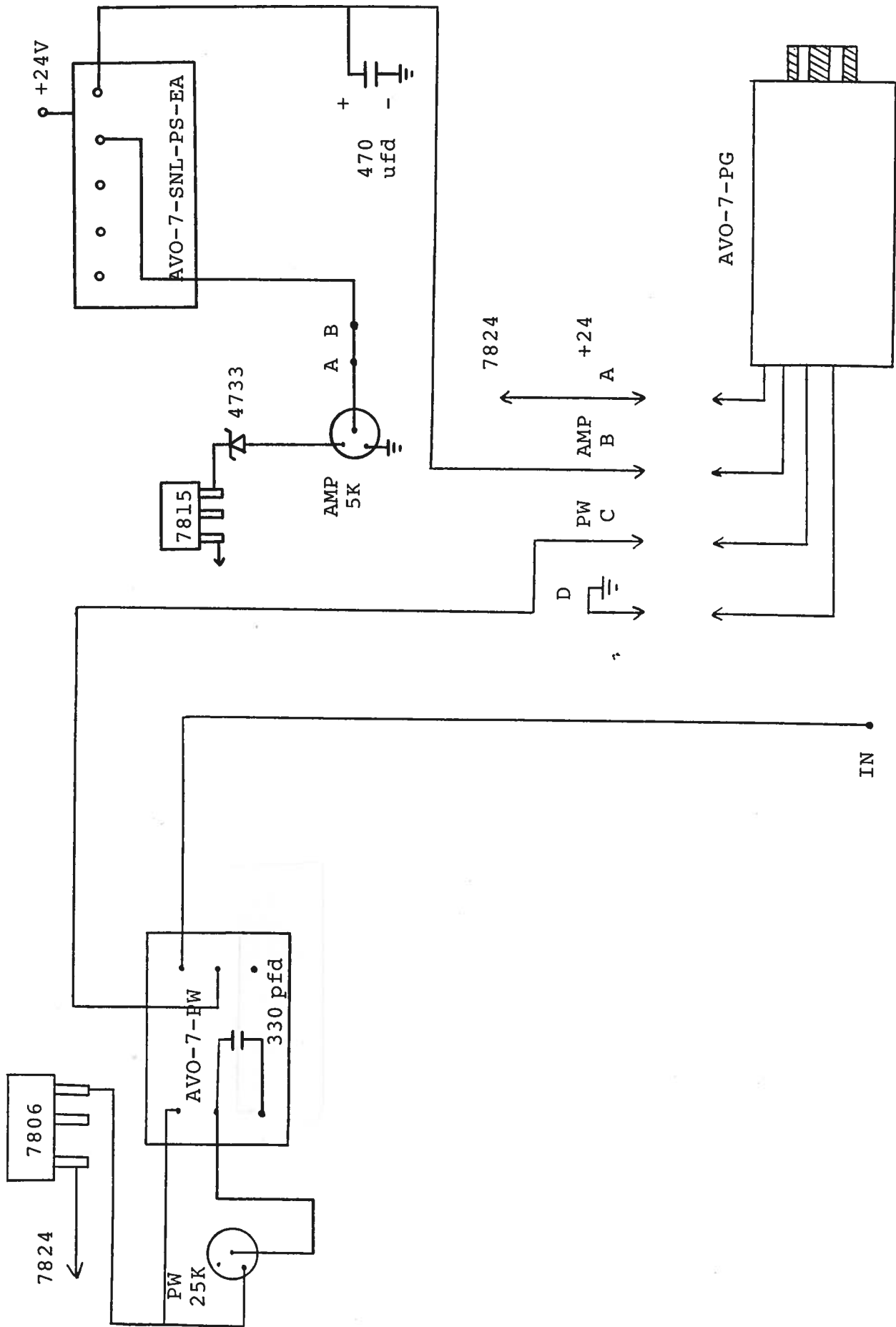

AVO-7A-PS-P-EA-SNL1 BLOCK DIAGRAM

Schroff

03.17.89

- A

