



AVTECH ELECTROSYSTEMS LTD.

NANOSECOND WAVEFORM ELECTRONICS
SINCE 1975

P.O. BOX 265
OGDENSBURG, NY
U.S.A. 13669-0265
TEL: (315) 472-5270
FAX: (613) 226-2802

TEL: 1-800-265-6681
FAX: 1-800-561-1970

e-mail: info@avtechpulse.com
<http://www.avtechpulse.com>

P.O. BOX 5120 STN. F
OTTAWA, ONTARIO
CANADA K2C 3H4
TEL: (613) 226-5772
FAX: (613) 226-2802

INSTRUCTIONS

MODEL AVO-7B2-C-LIA PULSE GENERATOR

S.N.:

WARRANTY

Avtech Electrosystems Ltd. warrants products of its manufacture to be free from defects in material and workmanship under conditions of normal use. If, within one year after delivery to the original owner, and after prepaid return by the original owner, this Avtech product is found to be defective, Avtech shall at its option repair or replace said defective item. This warranty does not apply to units which have been disassembled, modified or subjected to conditions exceeding the applicable specifications or ratings. This warranty is the extent of the obligation assumed by Avtech with respect to this product and no other warranty or guarantee is either expressed or implied.

TECHNICAL SUPPORT

Phone: 613-226-5772 or 1-800-265-6681

Fax: 613-226-2802 or 1-800-561-1970

E-mail: info@avtechpulse.com

World Wide Web: <http://www.avtechpulse.com>

TABLE OF CONTENTS

WARRANTY.....	2
TABLE OF CONTENTS	3
FIG. 1: PULSE GENERATOR TEST ARRANGEMENT	4
GENERAL OPERATING INSTRUCTIONS	5
FIG. 2: FRONT PANEL CONTROLS	7
FRONT PANEL CONTROLS	8
FIG. 3: BACK PANEL CONTROLS.....	10
BACK PANEL CONTROLS.....	11
SYSTEM DESCRIPTION AND REPAIR PROCEDURE	12
PERFORMANCE CHECK SHEET	13

FIG. 1: PULSE GENERATOR TEST ARRANGEMENT

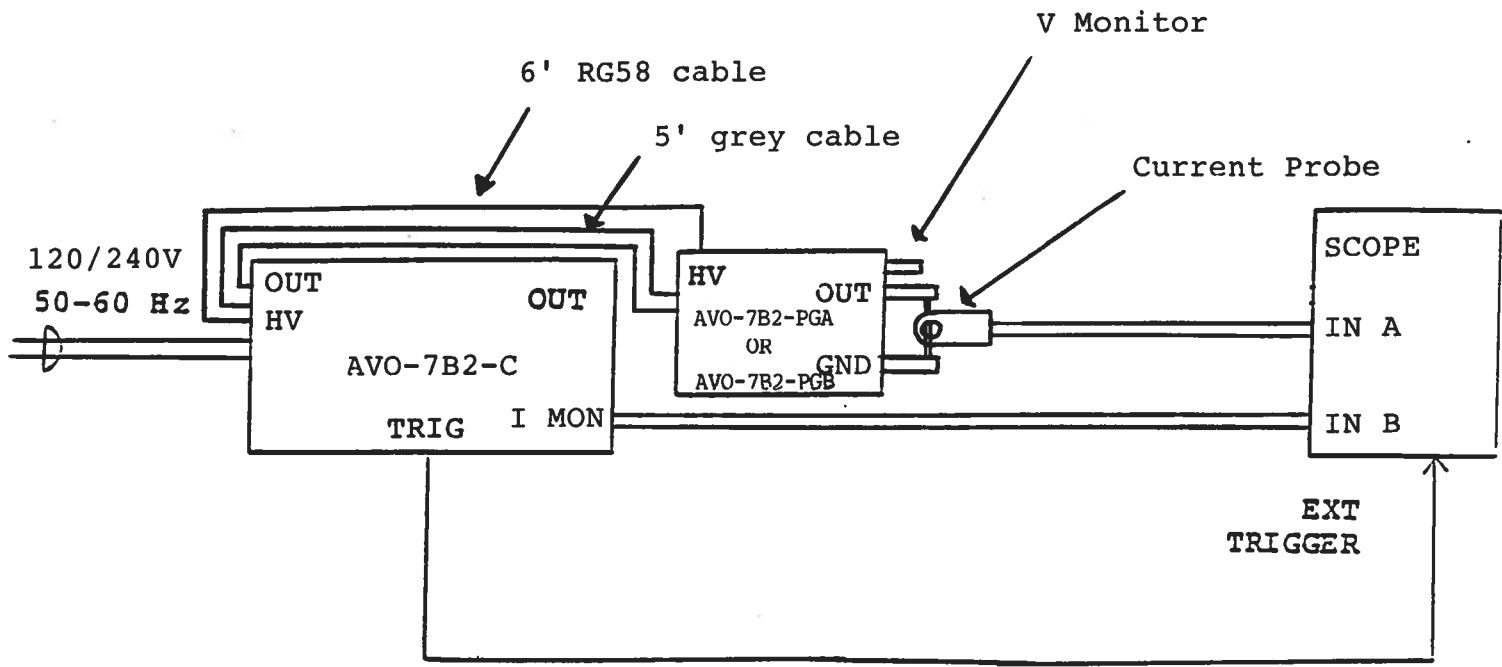

GENERAL OPERATING INSTRUCTIONS

- 1) The equipment should be connected in the general fashion shown above. Since the AVO unit provides an output pulse rise time as low as 0.5 us, a fast oscilloscope (at least 50 MHz) should be used to display the waveform. A high-current, non-inductive shorting bar should be connected between the "OUT" terminal and the ground terminal. The shorting bar should pass through a high speed current transformer (e.g. Pearson Electronics current transformer or Tektronix Model A6303 current probe).

Note that the gray cable from the -PG output module must be connected to the rear panel RS-232 style connector and the HV BNC connectors on the output module must be connected to the rear panel HV BNC connector using the black 6-foot RG-58 cable. The position of the front panel module switch must correspond with the output module which is connected (i.e. A or B).

- 2) The peak output current amplitude is limited by a self-contained, high-power resistor in the output stage. The voltage pulse applied to the input of this resistor may be viewed by connecting a voltage probe to the V_{MON} terminal on the output module. The voltage pulse amplitude is in the range of 0 to 23 Volts.
- 3) The TRIG output channel provides TTL level signals. The TRIG output precedes the main output when the front panel ADVANCE-DELAY switch is in the ADVANCE position. The TRIG output lags the main output when the switch is in the DELAY position.
- 4) To obtain a stable output display the PW and PRF controls on the front panel should be set mid-range. The front panel TRIG toggle switch should be in the INT position. The DELAY controls and the scope triggering controls are then adjusted to obtain a stable output. The scope may then be used to set the desired PRF by rotating the PRF controls.
- 5) The output pulse width is controlled by the ten turn PW control.
- 6) The output amplitude is controlled by the ten turn AMP control. Note that rapid clockwise rotation of the amplitude control may cause the overload control (see 10) to trigger and the amplitude control will momentarily become inactive. Control will be re-established in a few seconds. This can be avoided by increasing the amplitude slowly.
- 7) An external clock may be used to control the output PRF of the unit by setting the front panel TRIG toggle switch in the EXT position and applying a 50 ns (or wider) TTL level pulse to the TRIG BNC connector input. For operation in this mode, the scope time base must also be triggered by the external clock rather than from the TRIG output.
- 8) **CAUTION:** The AVO-7-C is designed to operate with a maximum duty cycle of 0.1% (e.g. PW = 200 us at PRF = 50 Hz).

- 9) **CAUTION:** The output stage is protected against overload condition by a 1.0 A slow blow fuse on the main frame back panel. However, the output switching elements may fail if the duty cycle rating is exceeded. Heating and subsequent likely failure of the output stage is reduced if the following action is taken where possible:
- 1) PRF is kept to a minimum.
 - 2) Keep the output PW to a minimum.
 - 3) Keep the load resistance as high as possible.
- 10) AVO-7 units with a serial number higher than 5600 are protected by an automatic overload protective circuit which controls the front panel overload light. If the unit is overloaded (by operating at an exceedingly high duty cycle or by operating into a short circuit), the protective circuit will turn the output of the instrument OFF and turn the indicator light ON. The light will stay ON (i.e. output OFF) for about 5 seconds after which the instrument will attempt to turn ON (i.e. light OFF) for about 1 second. If the overload condition persists, the instrument will turn OFF again (i.e. light ON) for another 5 seconds. If the overload condition has been removed, the instrument will turn on and resume normal operation. Overload conditions may be removed by:
- a) Reducing PRF
 - b) Reducing pulse width
- 11) If the unit is operated at duty cycles exceeding the maximum, the peak output current will not reach the specified maximum of 125 (or 500) Amps.
- 12) When testing sensors, the resistance in the sensor current path must not exceed 5 milli-ohms and the inductance must not limit the rise time of the 10 us rise time pulse provided by PGA or the 0.9 us rise time pulse provided by PGB. If the observed current rise times are higher than the voltage rise time observed at the voltage monitor terminal, then the inductance in the sensor path is excessive. For connecting the -PG output terminals to the sensor, consider using short lengths (less than 10 cm) of 2 cm wide 20 mm copper sheeting.
- 13) The unit can be converted from 120 to 240V 50-60 Hz operation by adjusting the voltage selector card in the rear panel fused voltage selector cable connector assembly.
- 14) For additional assistance:

Fax: 1-613-226-2802

Call: 1-613-226-5772

FIG. 2: FRONT PANEL CONTROLS

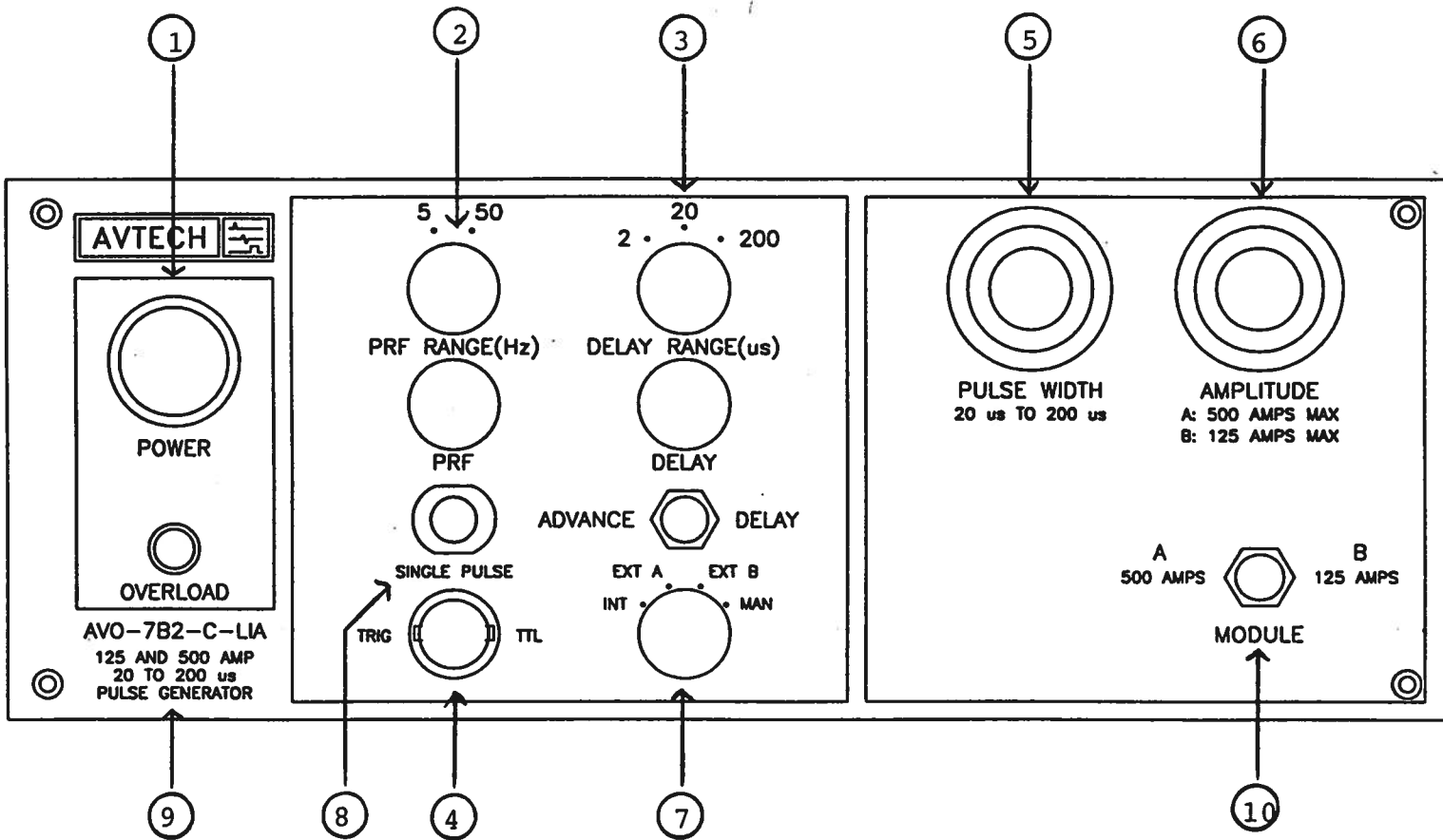

FRONT PANEL CONTROLS

- (1) ON-OFF Switch. Applies basic prime power to all stages.
- (2) PRF Control. Varies PRF from 0.5 Hz to 50 Hz as follows:
- | | |
|-----------|-------|
| 0.5 Hz to | 5 Hz |
| 5 Hz to | 50 Hz |
- (3) DELAY Control. Controls the relative delay between the reference output pulse provided at the TRIG output (4) and the main output (5). This delay is variable over the range of 0.2 to about 200 us. Delay LEADS or LAGS depending on the position of the ADVANCE-DELAY switch.
- (4) TRIG Output. This output is used to trigger the scope time base. The output is a TTL level 100 ns (approx.) pulse capable of driving a fifty ohm load. This output precedes the output if the two-position ADVANCE-DELAY switch is in the ADVANCE position. This output follows the output if the switch is in the DELAY position. The delay range is variable from 0.2 us to 200 us. The external trigger signal is applied at this input when the EXT-INT toggle switch is in the EXT position.
- (5) PW Control. A ten turn control which varies the output pulse width from 20 us to 200 us. The minimum and maximum PW for each range and the corresponding maximum PRF are as follows. The unit may fail if operated at duty cycles exceed 0.1%.
- | | |
|---------------|--------------|
| PW min | PW max |
| 20 us | 200 us |
| PRF max 50 Hz | PRF max 5 Hz |
- (6) AMP Control. A ten turn control which varies the output pulse amplitude from 0 to 500 Amps (Module A) or 0 to 125 Amps (Module B). The resistance in the load path must not exceed 5 milli-ohms. CAUTION: Rapid clockwise rotation of the amplitude control may cause the overload function (see 9) to trigger. This can be avoided by increasing the amplitude slowly.

- (7) INT-EXT-MAN Control. With this toggle switch in the INT position, the PRF of the AVO unit is controlled via an internal clock, which in turn is controlled by the PRF control. With the toggle switch in the EXT position, the AVO unit requires a 50 ns (or wider) TTL level pulse applied at the TRIG input in order to trigger the output stages. In addition, in this mode, the scope time base must be triggered by the external trigger source. When triggered externally, the output pulse width is controlled by the front panel PW controls, provided the MODE A-B switch is in the A position. When the MODE A-B switch is in the B position, the output pulse width equals the input trigger pulse width.
- (8) SINGLE PULSE. For single pulse manual operation, set the front panel INT-EXT-MAN switch in the MAN position and push the SINGLE PULSE button.
- (9) OVERLOAD INDICATOR. AVO-7B2-C units with a serial number higher than 5600 are protected by an automatic overload protective circuit which controls the front panel overload light. If the unit is overloaded (by operating at an exceedingly high duty cycle or by operating into a short circuit), the protective circuit will turn the output of the instrument OFF and turn the indicator light ON. The light will stay ON (i.e. output OFF) for about 5 seconds after which the instrument will attempt to turn ON (i.e. light OFF) for about 1 second. If the overload condition persists, the instrument will turn OFF again (i.e. light ON) for another 5 seconds. If the overload condition has been removed, the instrument will turn on and resume normal operation. Overload conditions may be removed by:
 - 1) Reducing PRF
 - 2) Reducing pulse width
- 10) MODULE SWITCH: The setting of this switch must correspond with the module connected to the mainframe output (i.e. A or B).

FIG. 3: BACK PANEL CONTROLS

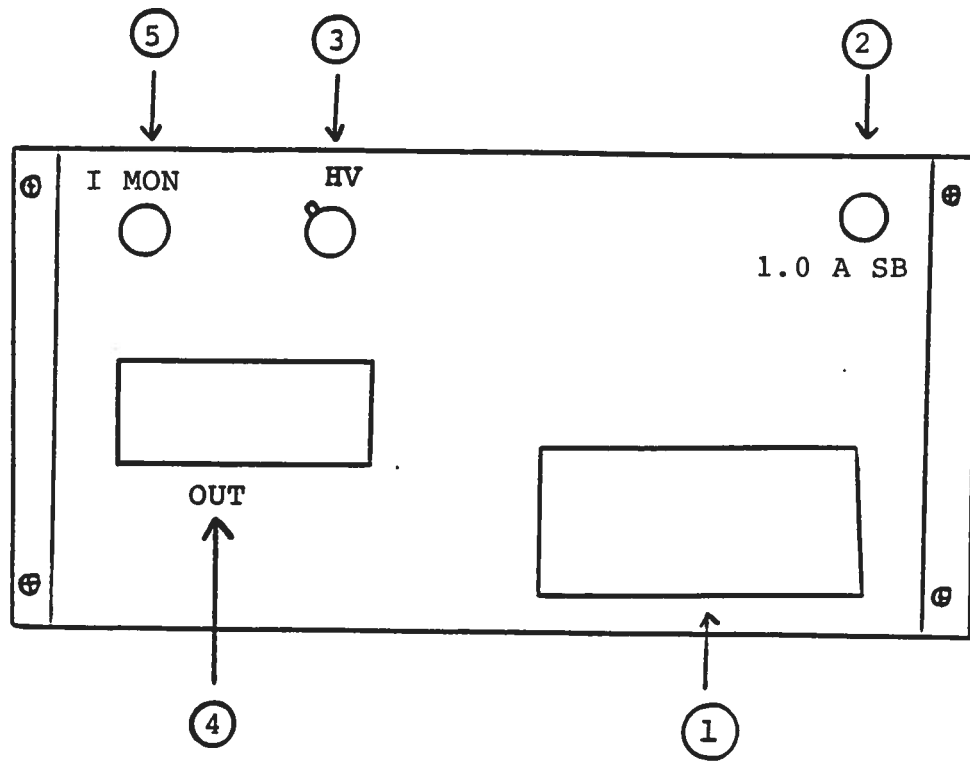

BACK PANEL CONTROLS

- (1) FUSED CONNECTOR, VOLTAGE SELECTOR. The detachable power cord is connected at this point. In addition, the removable cord is adjusted to select the desired input operating voltage. The unit also contains the main power fuse. (1.0 Amp SB)
- (2) 1.0A SB FUSE. Protects output stage against overload conditions.
- (3) HV BNC. This connector must be connected to the HV BNC connector on the -PG module via a 6-ft. length of RG58 cable.
- (4) OUT. The gray cable from the -PG output module must be connected to this RS-232 style connector.
- (5) I MON: This is the current monitor output. This output provides a voltage waveform (V_M) that is proportional to the current waveform (I_{LOAD}) on the main output. For a monitor load of $\geq 1K$, the monitor is:

FOR PGA:

$$I_{LOAD} = 50 V_M \text{ (Volts, Amps)}$$

For example, if V_M is 10 Volts, the load current is 500 Amps.

FOR PGB:

$$I_{LOAD} = 20 V_M \text{ (Volts, Amps)}$$

For example, if V_M is 5.0 Volts, the load current is 100 Amps.

The monitor output can also drive a 50Ω load, but the output voltage will be reduced by a factor of two. This output is short-circuit protected. Note that the monitor circuit rise time is 3 us so it will indicate a prolonged rise time when -PGB is connected.

SYSTEM DESCRIPTION AND REPAIR PROCEDURE

The AVO-7-C unit consists of the following basic modules:

- 1) AVO-7-PG pulse generator module
- 2) AVO-7-CL clock module
- 3) +24V and +33V power supply board
- 4) AVO-7-PW pulse width module

The modules are interconnected as shown in Fig. 4.

In the event of an instrument malfunction, it is most likely that the 1.0 A slow blow fuse or the main power fuse on the rear panel has blown. Replace if necessary. If the unit still does not function, it is most likely that some of the output switching elements may have failed due to an output short circuit condition or to a high duty cycle condition. The unit should be returned to Avtech for replacement of the output switching elements. If the switching elements are not defective, then the four Phillips screws on the back panel should be removed. The top cover may then be slid off and the operation of the clock and power supply modules checked. The clock module is functioning properly if:

- a) 0.1 us TTL level outputs are observed at pins 2 and 3.
- b) The PRF of the outputs can be varied over the range of 0.5 Hz to 50 Hz using the PRF controls.
- c) The relative delay between the pin 2 and 3 outputs can be varied by at least 1 us by the DELAY control.

The sealed clock module must be returned to Avtech for repair or replacement if the above conditions are not observed.

FIG. 3: BACK PANEL CONTROLS

