



**AVTECH ELECTROSYSTEMS LTD.**

NANOSECOND WAVEFORM ELECTRONICS  
SINCE 1975

P. O. BOX 265  
OGDENSBURG, NY  
U.S.A. 13669-0265  
TEL: (315) 472-5270  
FAX: (613) 226-2802

TEL: 1-800-265-6681  
FAX: 1-800-561-1970

e-mail: [info@avtechpulse.com](mailto:info@avtechpulse.com)  
<http://www.avtechpulse.com>

P.O. BOX 5120 STN. F  
OTTAWA, ONTARIO  
CANADA K2C 3H4  
TEL: (613) 226-5772  
FAX: (613) 226-2802

## INSTRUCTIONS

**MODEL AVO-7B2-C-SVMB PULSE GENERATOR**

**S.N.:**

### WARRANTY

Avtech Electrosystems Ltd. warrants products of its manufacture to be free from defects in material and workmanship under conditions of normal use. If, within one year after delivery to the original owner, and after prepaid return by the original owner, this Avtech product is found to be defective, Avtech shall at its option repair or replace said defective item. This warranty does not apply to units which have been disassembled, modified or subjected to conditions exceeding the applicable specifications or ratings. This warranty is the extent of the obligation assumed by Avtech with respect to this product and no other warranty or guarantee is either expressed or implied.

### TECHNICAL SUPPORT

Phone: 613-226-5772 or 1-800-265-6681

Fax: 613-226-2802 or 1-800-561-1970

E-mail: [info@avtechpulse.com](mailto:info@avtechpulse.com)

World Wide Web: <http://www.avtechpulse.com>

## TABLE OF CONTENTS

|  |    |
|--|----|
| WARRANTY.....                                  | 2  |
| TABLE OF CONTENTS .....                        | 3  |
| FIG. 1: PULSE GENERATOR TEST ARRANGEMENT ..... | 4  |
| GENERAL OPERATING INSTRUCTIONS .....           | 5  |
| FIG. 2: FRONT PANEL CONTROLS .....             | 7  |
| FRONT PANEL CONTROLS .....                     | 8  |
| FIG. 3: BACK PANEL CONTROLS .....              | 10 |
| BACK PANEL CONTROLS .....                      | 11 |
| SYSTEM DESCRIPTION AND REPAIR PROCEDURE.....   | 12 |
| PERFORMANCE CHECK SHEET .....                  | 13 |

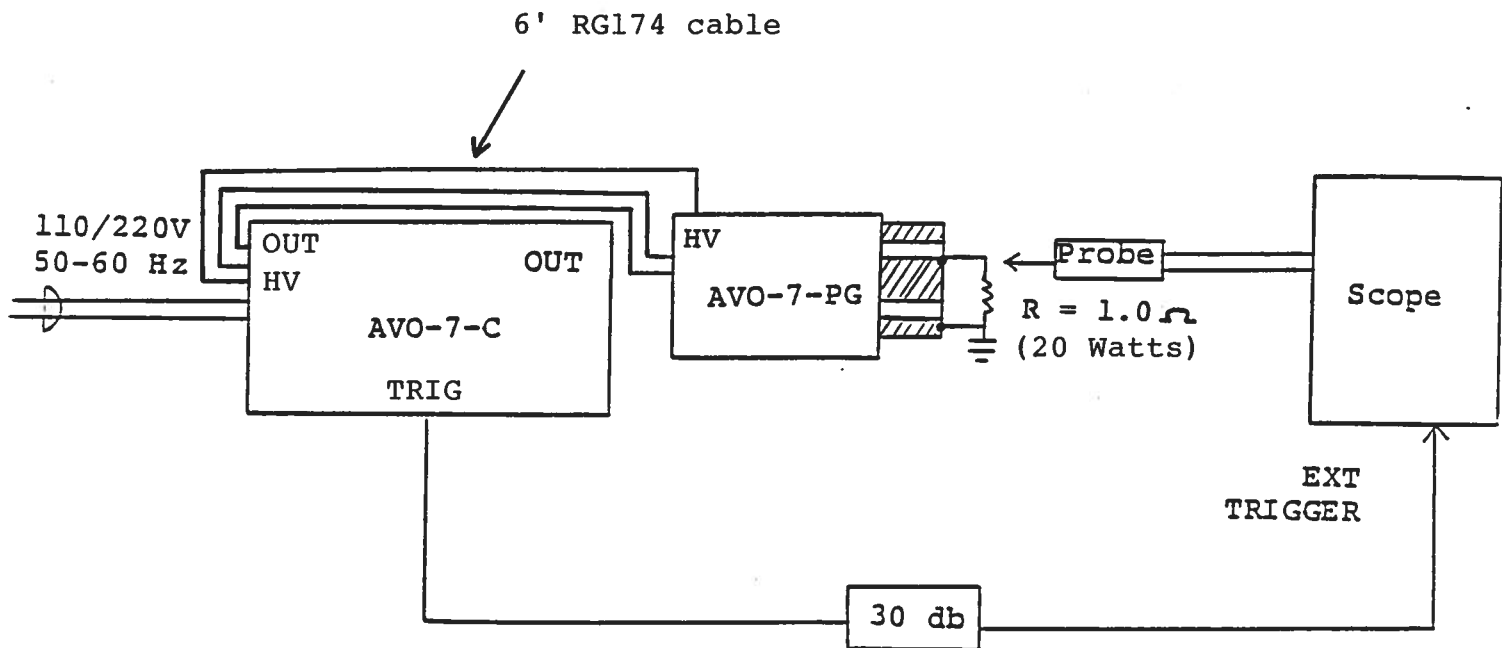
**FIG. 1: PULSE GENERATOR TEST ARRANGEMENT**

## GENERAL OPERATING INSTRUCTIONS

- 1) The equipment should be connected in the general fashion shown above. Since the AVO unit provides an output pulse rise time as low as 0.5 us, a fast oscilloscope (at least 50 MHz) should be used to display the waveform.

Note that the gray cable from the -PG output module must be connected to the rear panel RS-232 style connector and the HV SMA connectors on the output module must be connected to the rear panel HV SMA connector using the black 6-foot RG-174 cable.

**CAUTION:** Potentials as high as + 220 VDC are present on this cable.

- 2) The TRIG output channel provides TTL level signals. To avoid overdriving the TRIG input channel of some scopes, a 30 db attenuator should be placed at the input to the scope trigger channel. The TRIG output precedes the main output when the front panel ADVANCE-DELAY switch is in the ADVANCE position. The TRIG output lags the main output when the switch is in the DELAY position.
- 3) To obtain a stable output display the PW and PRF controls on the front panel should be set mid-range. The front panel TRIG toggle switch should be in the INT position. The DELAY controls and the scope triggering controls are then adjusted to obtain a stable output. The scope may then be used to set the desired PRF by rotating the PRF controls.
- 4) The output terminals of the pulse generator module consists of 10 SMA connectors connected in parallel. The peak current through each connector should not exceed 20 Amps.
- 5) The output pulse width is controlled by the ten turn PW control.
- 6) The output amplitude is controlled by the ten turn AMP control.
- 7) An external clock may be used to control the output PRF of the unit by setting the front panel TRIG toggle switch in the EXT position and applying a 50 us (or wider) TTL level pulse to the TRIG BNC connector input. For operation in this mode, the scope time base must also be triggered by the external clock rather than from the TRIG output.
- 8) The AVO-7 is designed to supply up to 200 amperes to a maximum load voltage of 200 volts. Factory tests are conducted with a 1.0 ohm load capable of dissipating at least 20 watts (ten 10 ohm loads in parallel). Higher load resistance values may be used but the output voltage will be limited to 200 volts.

- 9) **CAUTION:** The AVO-7-C is designed to operate with a maximum duty cycle of 0.05% (e.g. PW = 5 us at PRF = 100 Hz).
- 10) **CAUTION:** The output stage is protected against overload condition by a 1.0 A slow blow fuse on the main frame back panel. However, the output switching elements may fail if the duty cycle rating is exceeded. Heating and subsequent likely failure of the output stage is reduced if the following action is taken where possible:
- 1) PRF is kept to a minimum.
  - 2) Keep the output PW to a minimum.
  - 3) Keep the load resistance as high as possible.
- 11) AVO-7 units with a serial number higher than 5600 are protected by an automatic overload protective circuit which controls the front panel overload light. If the unit is overloaded (by operating at an exceedingly high duty cycle or by operating into a short circuit), the protective circuit will turn the output of the instrument OFF and turn the indicator light ON. The light will stay ON (i.e. output OFF) for about 5 seconds after which the instrument will attempt to turn ON (i.e. light OFF) for about 1 second. If the overload condition persists, the instrument will turn OFF again (i.e. light ON) for another 5 seconds. If the overload condition has been removed, the instrument will turn on and resume normal operation. Overload conditions may be removed by:
- a) Reducing PRF (i.e. switch to a lower range)
  - b) Reducing pulse width (i.e. switch to a lower range)
  - c) Removing output load short circuit (if any)
- 12) If the unit is operated at duty cycles exceeding the maximum, the peak output voltage (into one ohm) will not reach the specified maximum of 200 volts.
- 13) The unit can be converted from 110 to 220V 50-60 Hz operation by adjusting the voltage selector card in the rear panel fused voltage selector cable connector assembly.
- 14) For additional assistance:

Fax: 1-613-226-2802

Call: 1-613-226-5772

**FIG. 2: FRONT PANEL CONTROLS**

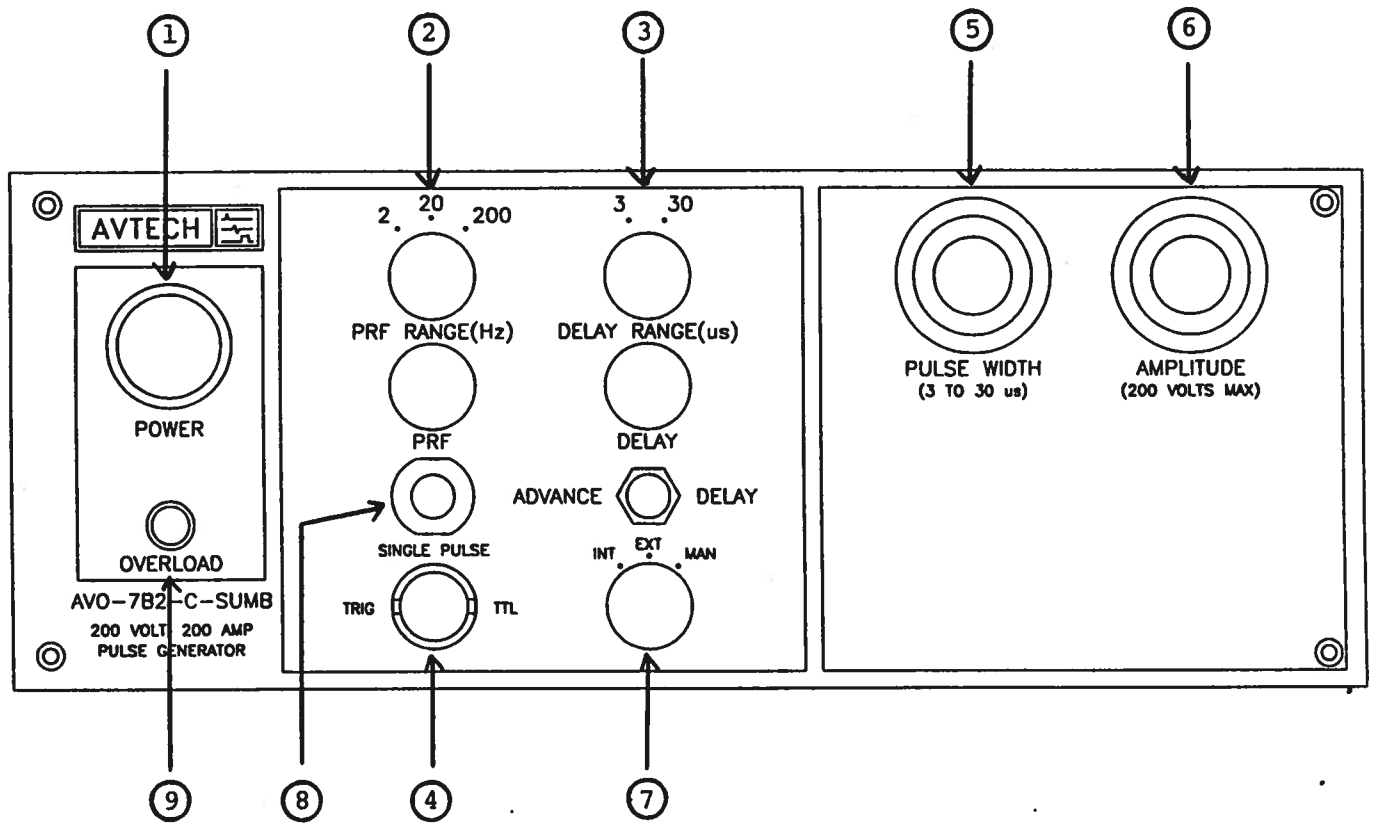

## FRONT PANEL CONTROLS

(1) ON-OFF Switch. Applies basic prime power to all stages.

(2) PRF Control. Varies PRF from 0.2 Hz to 200 Hz as follows:

0.2 Hz to 2 Hz  
2 Hz to 20 Hz  
20 Hz to 200 Hz

(3) DELAY Control. Controls the relative delay between the reference output pulse provided at the TRIG output (4) and the main output (5). This delay is variable over the range of 0.3 to about 30 us. Delay LEADS or LAGS depending on the position of the ADVANCE-DELAY switch.

(4) TRIG Output. This output is used to trigger the scope time base. The output is a TTL level 100 ns (approx) pulse capable of driving a fifty Ohm load. This output precedes the output if the two-position ADVANCE-DELAY switch is in the ADVANCE position. This output follows the output if the switch is in the DELAY position. The delay range is variable from 0.3 us to 30 us. The external trigger signal is applied at this input when the EXT-INT toggle switch is in the EXT position.

(5) PW Control. A one turn control (ten turn for -PWT option) and 3-position range switch which varies the positive output pulse width from 3 us to 30 us. The minimum and maximum PW for each range and the corresponding maximum PRF are as follows. The unit may fail if operated at duty cycles exceed the above (0.05%).

|                |               |
|----------------|---------------|
| PW min         | PW max        |
| 3 us           | 30 us         |
| PRF max 170 Hz | PRF max 17 Hz |

(6) AMP Control. A one turn control (ten turn for -AT option) which varies the output pulse amplitude from 0 to 200 Volts (to  $R_L \geq 1.0$  Ohms, 200 Amps max).



- (7) **INT-EXT-MAN Control.** With this toggle switch in the INT position, the PRF of the AVO unit is controlled via an internal clock which in turn is controlled by the PRF control. With the toggle switch in the EXT position, the AVO unit requires a 50 ns (or wider) TTL level pulse applied at the TRIG input in order to trigger the output stages. In addition, in this mode, the scope time base must be triggered by the external trigger source. When triggered externally, the output pulse width is controlled by the front panel PW controls, provided the MODE A-B switch is in the A position. The MODE A-B switch is accessed by removing the top cover (by removing the four Phillips screws on the cover panel and sliding the top cover back and off). When the MODE A-B switch is in the B position, the output pulse width equals the input trigger pulse width. The unit is shipped with the switch in the A position.
- (8) **SINGLE PULSE.** For single pulse manual operation, set the front panel INT-EXT-MAN switch in the MAN position and push the SINGLE PULSE button.
- (9) **OVERLOAD INDICATOR.** AVO-7B2-C units with a serial number higher than 5600 are protected by an automatic overload protective circuit which controls the front panel overload light. If the unit is overloaded (by operating at an exceedingly high duty cycle or by operating into a short circuit), the protective circuit will turn the output of the instrument OFF and turn the indicator light ON. The light will stay ON (i.e. output OFF) for about 5 seconds after which the instrument will attempt to turn ON (i.e. light OFF) for about 1 second. If the overload condition persists, the instrument will turn OFF again (i.e. light ON) for another 5 seconds. If the overload condition has been removed, the instrument will turn on and resume normal operation. Overload conditions may be removed by:
- 1) Reducing PRF (i.e. switch to a lower range)
  - 2) Reducing pulse width (i.e. switch to a lower range)
  - 3) Removing output load short circuit (if any)

FIG. 3: BACK PANEL CONTROLS

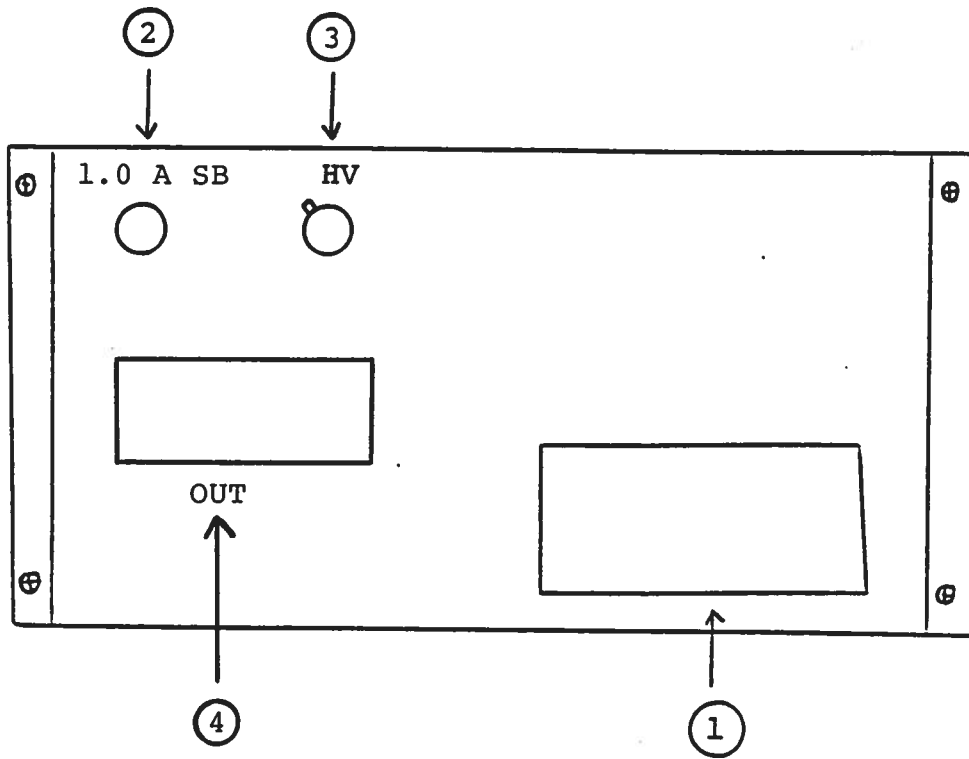

## BACK PANEL CONTROLS

- (1) FUSED CONNECTOR, VOLTAGE SELECTOR. The detachable power cord is connected at this point. In addition, the removable cord is adjusted to select the desired input operating voltage. The unit also contains the main power fuse. (1.5 amp SB)
- (2) 1.0A SB FUSE. Protects output stage against overload conditions.
- (3) HV SMA. This connector must be connected to the HV SMA connector on the -PG module via a 6 foot length of RG174 cable. CAUTION: The center conductor is at a potential as high as 220 volts DC.
- (4) OUT. The gray cable from the -PG output module must be connected to this RS-232 style connector.

## SYSTEM DESCRIPTION AND REPAIR PROCEDURE

The AVO-7-C unit consists of the following basic modules:

- 1) AVO-7-PG pulse generator module
- 2) AVO-7-CL clock module
- 3) +24V and +33V power supply board
- 4) AVO-7-PW pulse width module

The modules are interconnected as shown in Fig. 4.

In the event of an instrument malfunction, it is most likely that the 1.0 A slow blow fuse or the main power fuse on the rear panel has blown. Replace if necessary. If the unit still does not function, it is most likely that some of the output switching elements may have failed due to an output short circuit condition or to a high duty cycle condition. The unit should be returned to Avtech for replacement of the output switching elements. If the switching elements are not defective, then the four Phillips screws on the back panel should be removed. The top cover may then be slid off and the operation of the clock and power supply modules checked. The clock module is functioning properly if:

- a) 0.1  $\mu$ s TTL level outputs are observed at pins 2 and 3.
- b) The PRF of the outputs can be varied over the range of 1 Hz to 100 Hz using the PRF controls.
- c) The relative delay between the pin 2 and 3 outputs can be varied by at least 1  $\mu$ s by the DELAY control.

The sealed clock module must be returned to Avtech for repair or replacement if the above conditions are not observed.

PERFORMANCE CHECK SHEET



AVTECH ELECTROSYSTEMS. LTD.

NANOSECOND WAVEFORM ELECTRONICS  
SINCE 1975

P.O. BOX 265  
OGDENSBURG, NY  
U.S.A. 13669-0265  
TEL: (315) 472-5270  
FAX: (613) 226-2802

TEL: 1-800-265-6681  
FAX: 1-800-561-1970

e-mail: info@avtechpulse.com  
http://www.avtechpulse.com

P.O. BOX 5120 STN. F  
OTTAWA, ONTARIO  
CANADA K2C 3H4  
TEL: (613) 226-5772  
FAX: (613) 226-2802

Fax Ref. No: 3487  
To: SV Microwave, FL  
Attn: Jim Walker  
Phone: 561-840-1800 Ext. 45  
Subject: 200V, 200 Amp pulser

From: Avtech Electrosystems Ltd.  
Our Fax No: (613) 226-2802  
Date: April 1, 1998  
Receivers Fax No: 561-844-8551  
No. of pages: 2  
C.C.

Following our telephone conversation of March 30th, I am pleased to offer a revised price and delivery quotation for a 200 Volt, 200 Amp pulser meeting the following specifications:

Quote No: 8633.  
Model designation: AVO-7B2-C-P-SVMB.  
Output amplitude: 0 to +200 Volts to  $R_L \geq 1$  Ohm (200 Amps max). Ten turn control. The load impedance may lie in the range of 1 to 50 Ohms and the output connection consists of 10 parallel SMA connectors.  
Pulse width: 3 to 30 us (ten turn control).  
Rise, fall time:  $R_L = 50$  Ohms:  $\leq 0.5$  us.  
 $R_L = 1$  Ohm:  $\leq 1.0$  us.  
Output impedance:  $\leq 0.02$  Ohms.  
PRF: 0 to 200 Hz.  
Max duty cycle: 0.1% (eg. PW = 10 us, PRF max = 100 Hz).  
Other: See standard AVO-7B2-C, pages 68 and 69, Cat. No. 9.

Price:

\$4,915.00 US each, FOB destination.

Delivery:

60-90 days ARO.

Thank you for your continuing interest in our products. Please call me again (1-800-265-6681) if you require any additional information.

Regards,

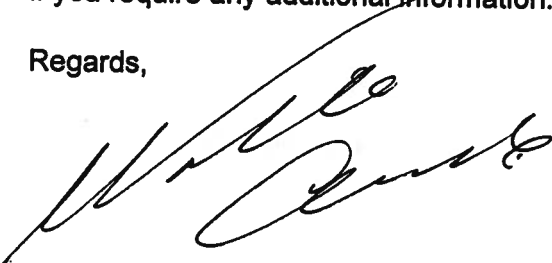
A handwritten signature in black ink, appearing to read 'Walter Chudobiak', written in a cursive style.

Dr. Walter Chudobiak  
Chief Engineer

WC:pr

July 17/98

instructword | avo 7b+c | avo-7b2-c, symb.doc