

AVTECH ELECTROSYSTEMS LTD.

NANOSECOND WAVEFORM ELECTRONICS
ENGINEERING - MANUFACTURING

□ P.O. BOX 265
OGDENSBURG
NEW YORK
13669
(315) 472-5270

☒ BOX 5120, STN. "F"
OTTAWA, ONTARIO
CANADA K2C 3H4
TEL: (613) 226-5772
FAX: (613) 226-2802
TELEX: 053-4591

INSTRUCTIONS

MODEL AVO-7B-C-PN-EA PULSE GENERATOR

S.N. :

WARRANTY

Avtech Electrosystems Ltd. warrants products of its manufacture to be free from defects in material and workmanship under conditions of normal use. If, within one year after delivery to the original owner, and after prepaid return by the original owner, this Avtech product is found to be defective, Avtech shall at its option repair or replace said defective item. This warranty does not apply to units which have been disassembled, modified or subjected to conditions exceeding the applicable specifications or ratings. This warranty is the extent of the obligation or liability assumed by Avtech with respect to this product and no other warranty or guarantee is either expressed or implied.

Fig. 1

PULSE GENERATOR TEST ARRANGEMENT

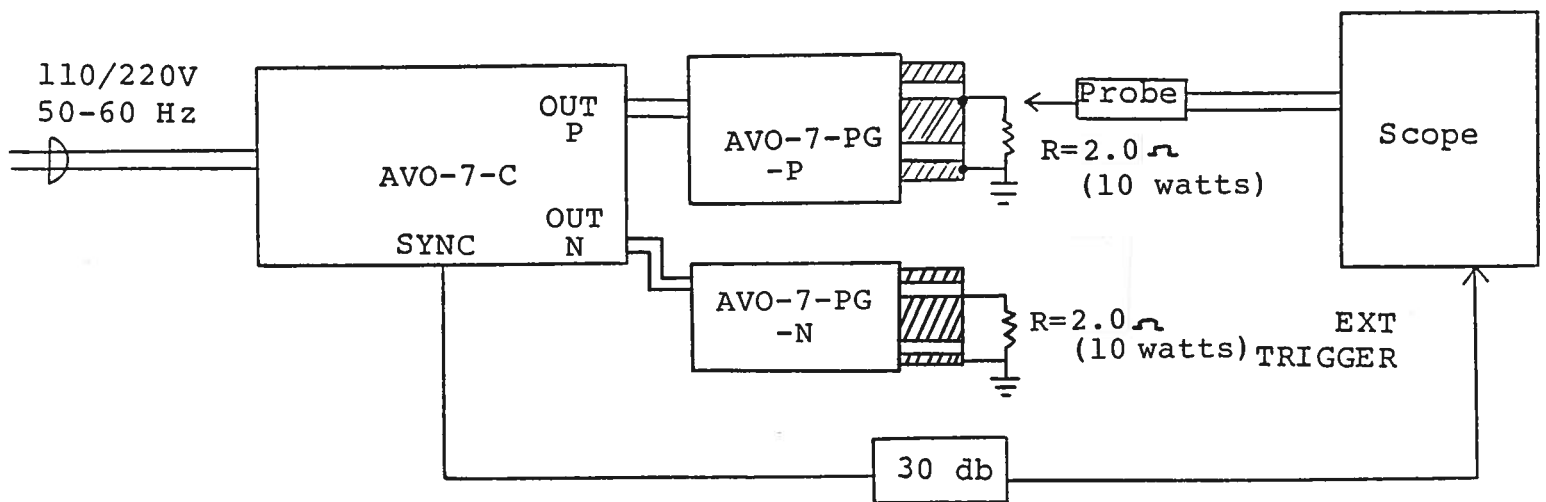

GENERAL OPERATING INSTRUCTIONS

- 1) The equipment should be connected in the general fashion shown above. Since the AVO unit provides an output pulse rise time as low as 100 nsec a fast oscilloscope (at least 50 MHz and preferably 200 MHz) should be used to display the waveform.
- 2) The sync output channel provides TTL level signals. To avoid overdriving the TRIG input channel of some sampling scopes, a 30 db attenuator should be placed at the input to the sampling scope trigger channel.
- 3) The desired output polarity is selected by means of the front panel POLARITY switch. With the POLARITY switch in the P position, the negative output pulse generator is rendered inactive. Likewise, with the POLARITY switch in the N position, the positive pulse generator is rendered inactive.
- 4) To obtain a stable output display the PRF and PRF FINE controls on the front panel should be set mid-range. The front panel TRIG toggle switch should be in the INT position. The front panel DELAY control and the scope triggering controls are then adjusted to obtain a stable output. The scope may then be used to set the desired PRF by rotating the PRF and PRF FINE controls. The main output is delayed with respect to the SYNC output by about 0 to 1 usec depending on the DELAY control setting.
- 5) The output terminals of the pulse generator module consists of a short length of microstrip transmission line protruding from the module chassis. The OUT terminal is the center conductor which is bounded on both sides by the ground plane (see below):

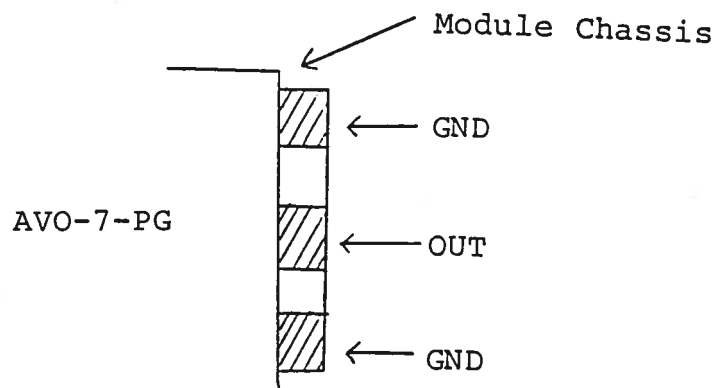

The load should be connected between the OUT and GND terminals using very short leads (≤ 0.5 cm). The voltage across the load may be monitored by connecting a length of 80 mil semi-rigid 50 ohm cable as shown below (or by means of a high impedance scope probe):

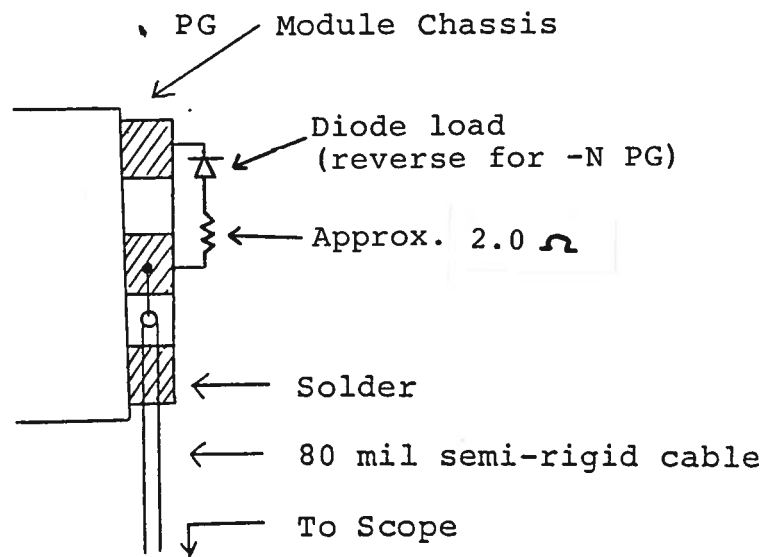

Take care to insure that during soldering the OUT conductor is not shorted to the chassis. Also, use minimal heat when soldering.

- 6) To voltage control the output pulse width, set the rear panel switch in the EXT position and apply 0 to +10V between terminal A and ground ($R_{IN} \gg 10K$). (option).
- 7) To voltage control the output amplitude, set the rear panel switch in the EXT position and apply 0 to +10V between terminal A and ground ($R_{IN} \gg 10K$). (option).
- 8) An external clock may be used to control the output PRF of the unit by setting the front panel TRIG toggle switch in the EXT position and applying a 0.2 usec (approx) TTL level pulse to the TRIG BNC connector input. For operation in this mode, the scope time base must also be triggered by the external clock rather than from the SYNC output.

- 9) The AVO-7 is designed to supply up to 20 amperes to a maximum load voltage of 40 volts. Factory tests are conducted with a 2.0 ohm load capable of dissipating at least 10 watts. Higher load resistance values may be used but the output voltage must be limited to 40 volts or less.
- 10) CAUTION: The AVO-7-C is designed to operate with a maximum duty cycle of 1%. For example at PRF up to 50 Hz, the full 200 usec PW may be employed. At 1 KHz PRF, the maximum allowable PW is reduced to 10 usec.
- 11) CAUTION: The output stage is protected against overload condition by a 0.5 A slow blow fuse on the main frame back panel. However, the output switching elements (SL10T) may fail if the duty cycle rating is exceeded. Heating and subsequent likely failure of the output stage is reduced if the following action is taken where possible:
 - a) PRF is kept to a minimum, ie. operate in the LOW PRF range when possible rather than in the HIGH range.
 - b) Keep the output PW to a minimum.
 - c) Keep the load resistance as high as possible.
- 12) The unit can be converted from 110 to 220V 50-60 Hz operation by adjusting the voltage selector card in the rear panel fused voltage selector cable connector assembly.
- 13) MONITOR Option. The M output connector on the PG module provides a voltage pulse (to 1K or higher) where amplitude is proportional to the output peak load current. An output current of 20 amperes provides a monitor voltage of 2.2 volts.

Fig. 2

FRONT PANEL CONTROLS

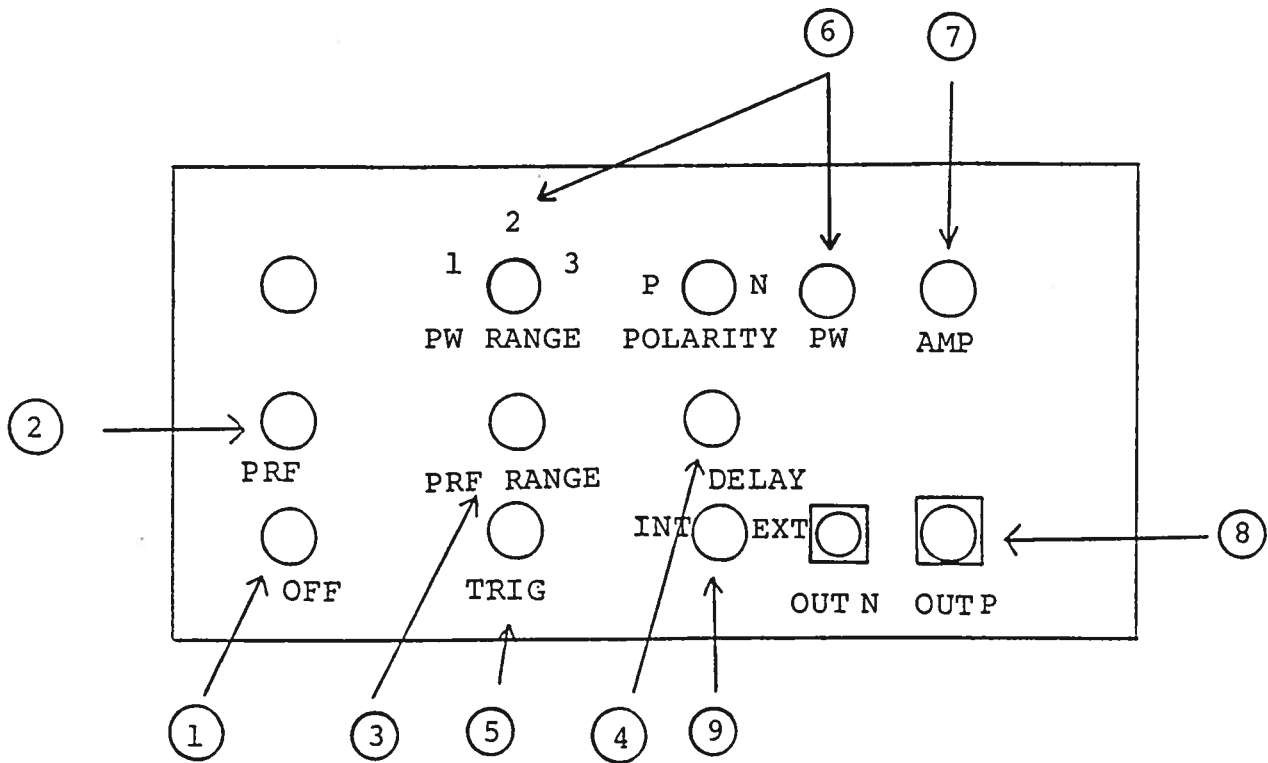

- (1) ON-OFF Switch. Applies basic prime power to all stages.
- (2) PRF Control. Varies PRF from about 2 to about 50 Hz
- (3) (LOW range) and 20 Hz to 1000 Hz (HIGH range). The operating PRF should be set using a scope. Do not exceed duty cycle rating of 1%.
- (4) DELAY Control. Controls the relative delay between the reference output pulse provided at the TRIG output (6) and the main output (8). This delay is variable over the range of 0 to about 1 usec.
- (5) TRIG Output. This output precedes the main output (9) and is used to trigger the sampling scope time base. The output is a TTL level 100 nsec (approx.) pulse capable of driving a fifty ohm load. The external trigger signal is applied at this input when the EXT toggle switch (9) is in the EXT position. The output pulse appears about 60 nsec after the application of the TRIG pulse.
- (6) PW Control. A one turn control and 3 position range switch which varies the output pulse width from 0.2 usec to 200 usec.
- (7) AMP Control. The output pulse amplitude is controlled by means of the one turn potentiometer (AMP).
- (8) OUT Connector. A multi pin connector which attaches the 2 foot cable from the pulse generator module to the main frame.
- (9) EXT-INT Control. With this toggle switch in the INT position, the PRF of the AVO unit is controlled via an internal clock which in turn is controlled by the PRF controls. With the toggle switch in the EXT position, the AVO unit requires a 0.2 usec TTL level pulse applied at the TRIG input in order to trigger the output stages. In addition, in this mode, the scope time base must be triggered by the external trigger source.

Fig. 3

BACK PANEL CONTROLS

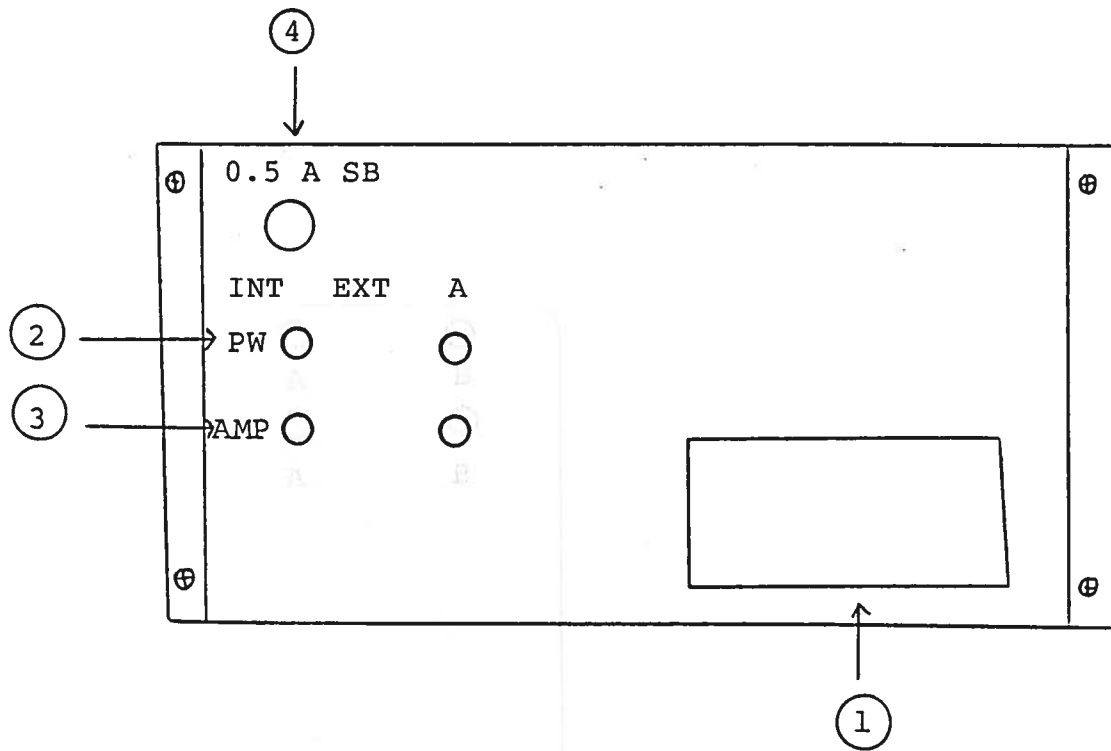

- (1) FUSED CONNECTOR, VOLTAGE SELECTOR. The detachable power cord is connected at this point. In addition, the removable cord is adjusted to select the desired input operating voltage. The unit also contains the main power fuse.
- (2) To voltage control the output pulse width, set the switch in the EXT position and apply 0 to +10V between terminal A and ground ($R_{IN} \gg 10K$). (option).
- (3) To voltage control the output amplitude, set the switch in the EXT position and apply 0 to +10V between terminal A and ground ($R_{IN} \gg 10K$). (option).
- (4) 0.5 A SB FUSE. Protects output stage against overload conditions.

Fig. 4

SYSTEM BLOCK DIAGRAM

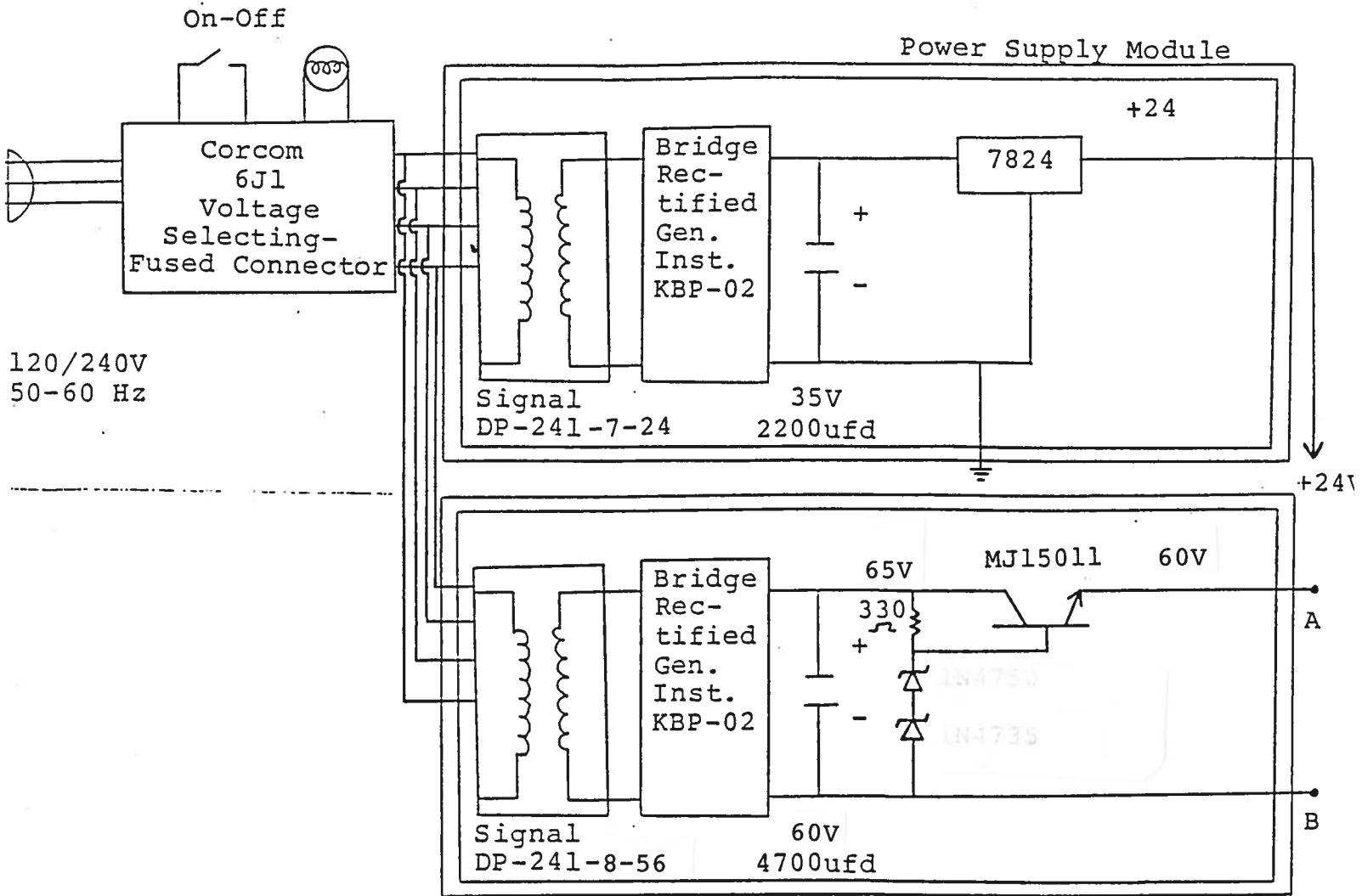

AVO-7-C-PN-EA BLOCK DIAGRAM

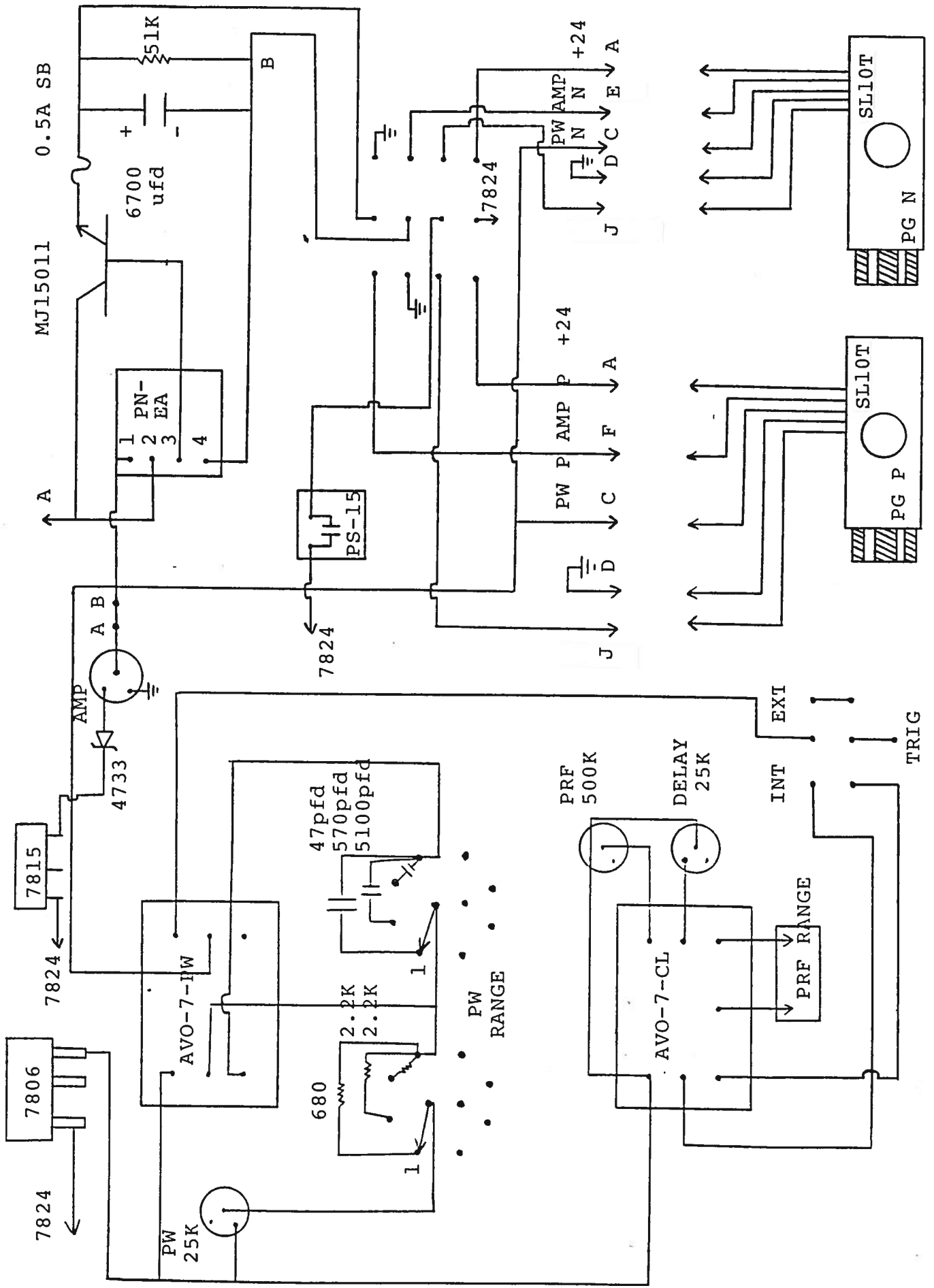

BACK

-P-P6

FRONT

155
HEAT SINK
ADHESIVE*

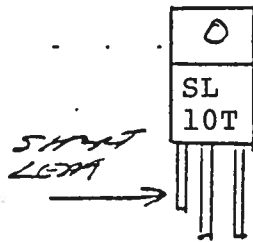
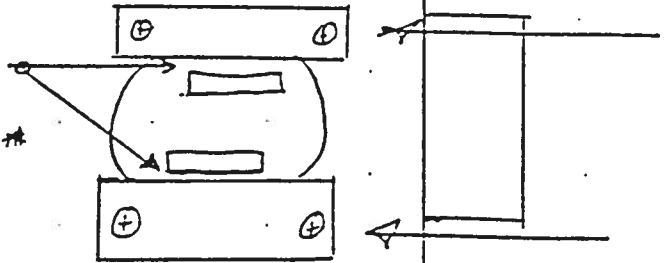

BACK

-N-P6

FRONT

155 HEAT
SINK
ADHESIVE*

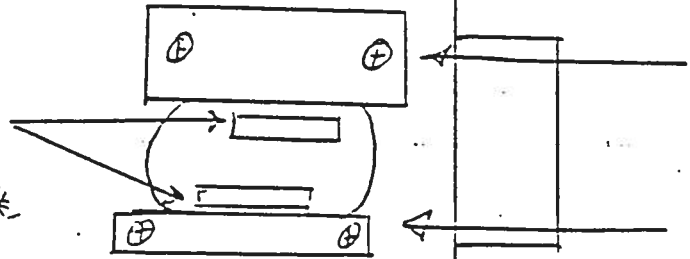

*
CAUTION INSURE THAT
TABS OF SLIT
DO NOT CONTACT
ITS GRIDS.

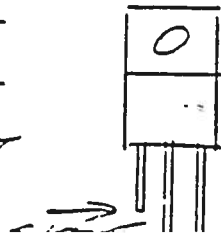

SYSTEM DESCRIPTION AND REPAIR PROCEDURE

The AVO-7-C-PN unit consists of the following basic modules:

- 1) AVO-7-PG pulse generator module
- 2) AVO-7-CL clock module
- 3) +24V and +33V power supply board
- 4) AVO-7-PW pulse width module

The modules are interconnected as shown in Fig. 4.

In the event of an instrument malfunction, it is most likely that the 0.5 A slow blow fuse or the main power fuse on the rear panel has blown. Replace if necessary. If the unit still does not function, it is most likely that some of the output switching elements (SL10T) may have failed due to an output short circuit condition or to a high duty cycle condition. The switching elements may be accessed by removing the cover plate on the bottom side of the -PG module. The cover plate is removed by removing the four counter sunk 6-32 Phillips screws. NOTE: First turn off the prime power. CAUTION: Briefly ground the SL10T tabs to discharge the 60 volts power supply potential. The elements may be removed from their sockets by means of a needle nosed pliers after removing the four counter sunk 2-56 Phillips screws which attach the small aluminum heat sinks to the body of the AVO-7-PG module. The SL10T is a selected VMOS power transistor in a TO 220 package and may be checked on a curve tracer. If defective, replacement units should be ordered directly from Avtech. When replacing the SL10T switching elements, take care to insure that the short lead (of the three leads) is adjacent to the back of the chassis. (See following Fig.). The SL10T elements are electrically isolated from the small aluminum heat sinks but are bonded to the heat sinks using WAKEFIELD TYPE 155 HEAT SINK ADHESIVE. If the switching elements are not defective, then the four Phillips screws on the back panel should be removed. The top cover may then be slid off and the operation of the clock and power supply modules checked. The clock module is functioning properly if:

- a) 0.1 usec TTL level outputs are observed at pins 2 and 3.
- b) The PRF of the outputs can be varied over the range of 2 Hz to 1 KHz using the PRF controls.
- c) The relative delay between the pin 2 and 3 outputs can be varied by at least 1 usec by the DELAY control.

The sealed clock module must be returned to Avtech for repair or replacement if the above conditions are not observed.

Schroff

11.14.89

Edition A

-EW

-M