

# AVTECH ELECTROSYSTEMS LTD.

NANOSECOND WAVEFORM ELECTRONICS  
ENGINEERING - MANUFACTURING

□ P.O. BOX 265  
OGDENSBURG  
NEW YORK  
13669  
(315) 472-5270

✕ BOX 5120, STN. "F"  
OTTAWA, ONTARIO  
CANADA K2C 3H4  
TEL: (613) 226-5772  
FAX: (613) 226-2802  
TELEX: 053-4591

## INSTRUCTIONS

MODEL AVD-7C-C-IITA PULSE GENERATOR

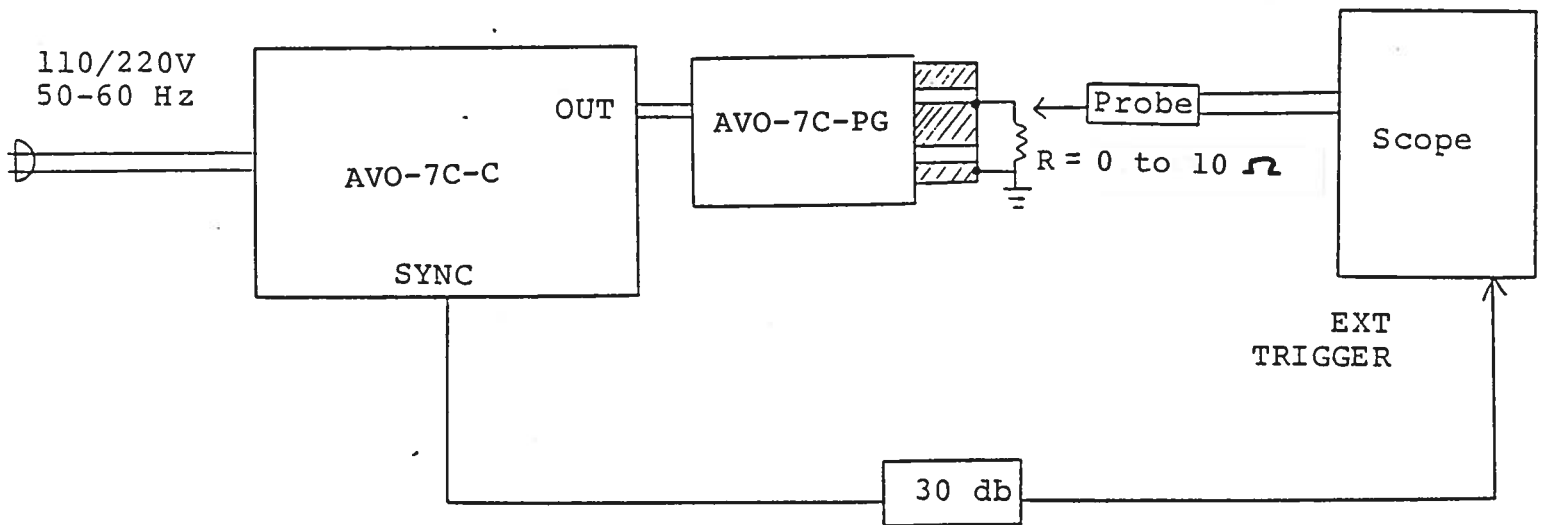
S.N.:

## WARRANTY

Avtech Electrosystems Ltd. warrants products of its manufacture to be free from defects in material and workmanship under conditions of normal use. If, within one year after delivery to the original owner, and after prepaid return by the original owner, this Avtech product is found to be defective, Avtech shall at its option repair or replace said defective item. This warranty does not apply to units which have been disassembled, modified or subjected to conditions exceeding the applicable specifications or ratings. This warranty is the extent of the obligation or liability assumed by Avtech with respect to this product and no other warranty or guarantee is either expressed or implied.

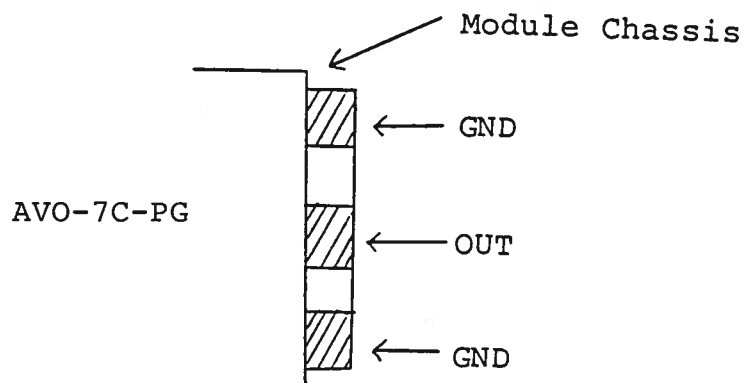
Fig. 1

PULSE GENERATOR TEST ARRANGEMENT

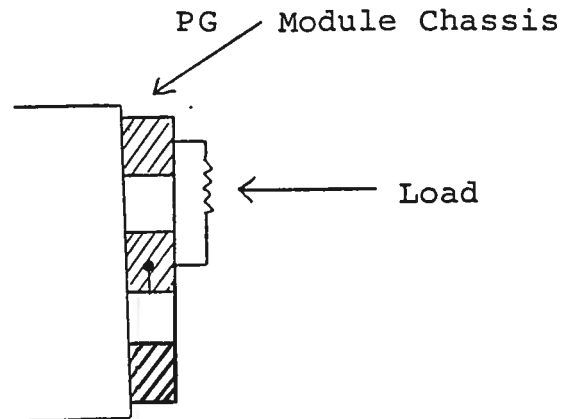


## GENERAL OPERATING INSTRUCTIONS

- 1) The equipment should be connected in the general fashion shown above. Since the AVO unit provides an output pulse rise time as low as 100 nsec a fast oscilloscope (at least 50 MHz and preferably 200 MHz) should be used to display the waveform.
- 2) The sync output channel provides TTL level signals. To avoid overdriving the TRIG input channel of some sampling scopes, a 30 db attenuator should be placed at the input to the sampling scope trigger channel.
- 3) To obtain a stable output display the PRF control on the front panel should be set mid-range. The front panel TRIG toggle switch should be in the INT position. The front panel DELAY control and the scope triggering controls are then adjusted to obtain a stable output. The scope may then be used to set the desired PRF by rotating the PRF control. The main output is delayed with respect to the SYNC output by about 0 to 1 usec depending on the DELAY control setting. **CAUTION:** Do not exceed duty cycle rating of 3%.
- 4) The output terminals of the pulse generator module consists of a short length of microstrip transmission line protruding from the module chassis. The OUT terminal is the center conductor which is bounded on both sides by the ground plane (see below):



The load should be connected between the OUT and GND terminals using short leads ( $\ll 1.0$  inch). The voltage across the load may be monitored by means of a high impedance scope probe.



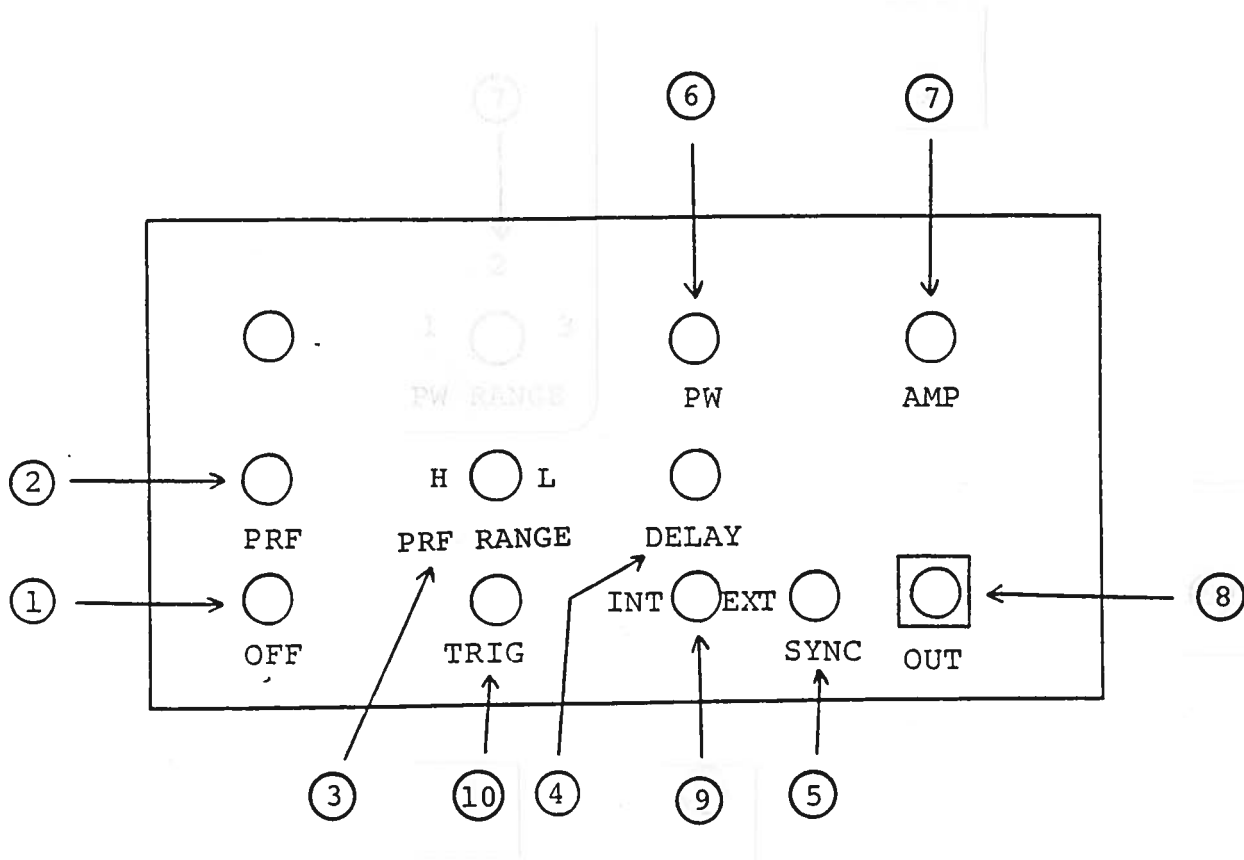
Take care to insure that during soldering the OUT conductor is not shorted to the chassis. Also, use minimal heat when soldering.

- 5) An external clock may be used to control the output PRF of the unit by setting the front panel TRIG toggle switch in the EXT position and applying a 0.2 usec (approx) TTL level pulse to the TRIG BNC connector input. For operation in this mode, the scope time base must also be triggered by the external clock rather than from the SYNC output.
- 6) The AVO-7C is designed to supply up to 3 amperes to a maximum load voltage of 30 volts. Factory tests are conducted with a 10 ohm load capable of dissipating at least 10 watts. Higher load resistance values may be used but the output voltage must be limited to 30 volts or less.

- 7) CAUTION: At max output pulse width and amplitude, the unit will operate at PRF as high as 3 KHz. For pulse width of 10 usec, the unit will operate at PRF as high as 33 KHz. If the above PRF ratings are exceeded the realizable maximum output amplitude will decrease and in severe cases lead to the failure of the output switching elements.
  
- 8) CAUTION: The output stage is protected against overload condition by a 1.0 A slow blow fuse on the main frame back panel. However, the output switching elements may fail if the duty cycle rating is exceeded. Heating and subsequent likely failure of the output stage is reduced if the following action is taken where possible:
  - a) PRF is kept to a minimum, ie. operate in the LOW PRF range when possible rather than in the HIGH range.
  - b) Keep the output PW to a minimum.
  - c) Keep the load resistance as high as possible.
  
- 9) The unit can be converted from 110 to 220V 50-60 Hz operation by adjusting the voltage selector card in the rear panel fused voltage selector cable connector assembly.

Fig. 2

FRONT PANEL CONTROLS

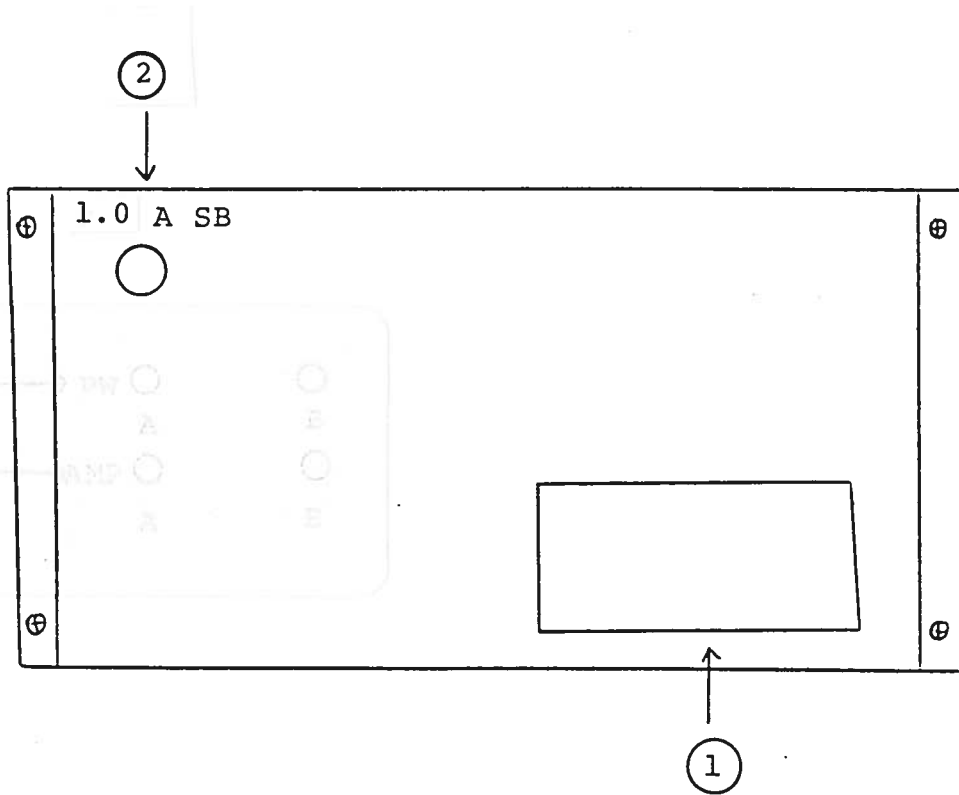


- (1) ON-OFF Switch. Applies basic prime power to all stages.
- (2) PRF Control. Varies PRF from about 2 to about 3 KHz
- (3) (LOW range) and 20 Hz to 33 KHz (HIGH range). The operating PRF should be set using a scope.
- (4) DELAY Control. Controls the relative delay between the reference output pulse provided at the SYNC output (5) and the main output (8). This delay is variable over the range of 0 to about 1 usec.
- (5) SYNC Output. This output precedes the main output (8) and is used to trigger the sampling scope time base. The output is a TTL level 100 nsec (approx.) pulse capable of driving a fifty ohm load.
- (6) PW Control. A one turn control that varies PW from 10 to 100 usec.
- (7) AMP Control. The output pulse amplitude is controlled by means of the one turn potentiometer (AMP).
- (8) OUT Connector. A multi pin connector which attaches the 2 foot cable from the pulse generator module to the main frame.
- (9) EXT-INT Control. With this toggle switch in the INT position, the PRF of the AVO unit is controlled via an internal clock which in turn is controlled by the PRF controls. With the toggle switch in the EXT position, the AVO unit requires a 0.2 usec TTL level pulse applied at the TRIG input in order to trigger the output stages. In addition, in this mode, the scope time base must be triggered by the external trigger source.
- (10) TRIG Input. The external trigger signal is applied at this input when the EXT toggle switch is in the EXT position. The output pulse appears about 100 nsec after the application of the TRIG pulse.

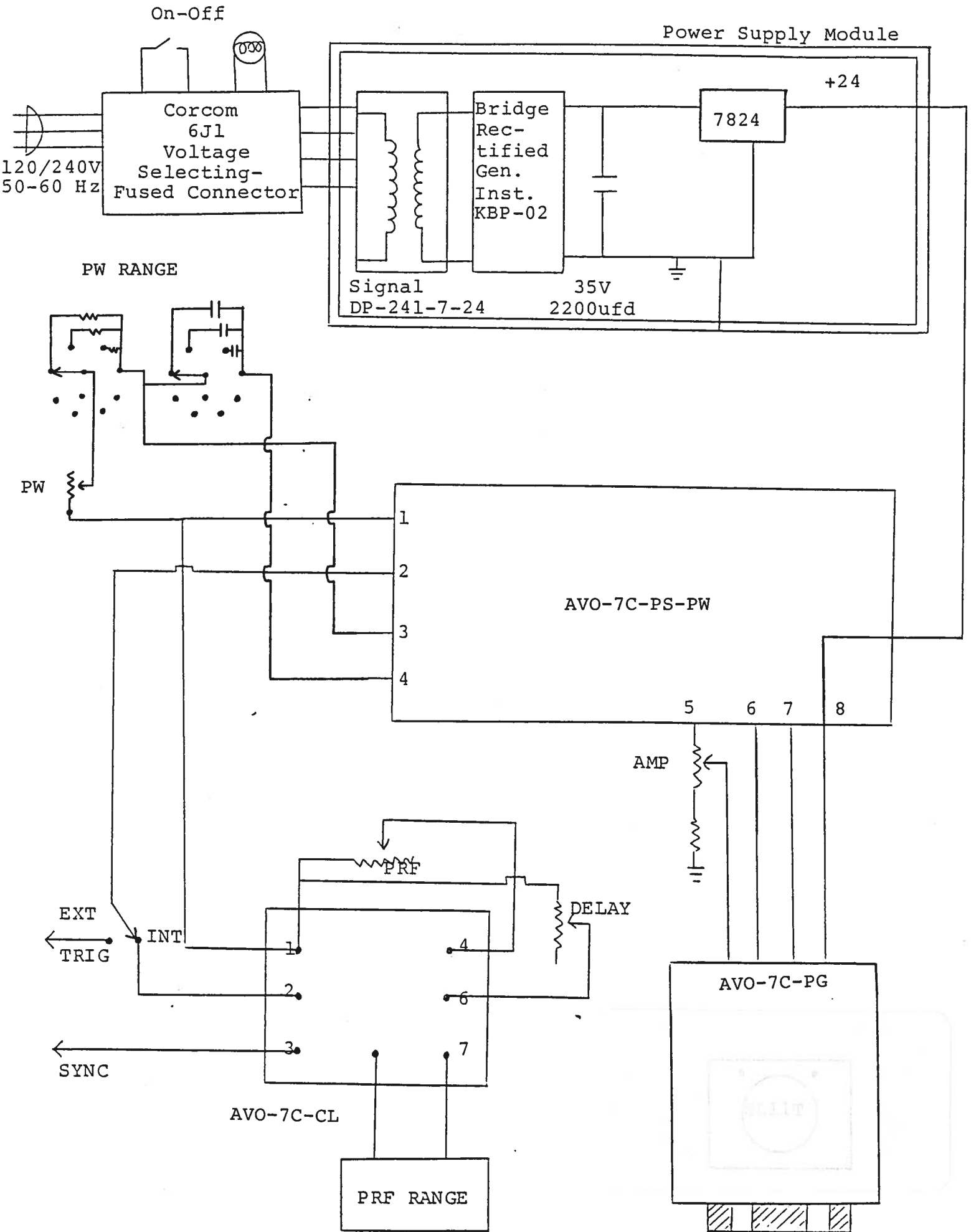


Fig. 3

BACK PANEL CONTROLS



- (1) FUSED CONNECTOR, VOLTAGE SELECTOR. The detachable power cord is connected at this point. In addition, the removable cord is adjusted to select the desired input operating voltage. The unit also contains the main power fuse.
- (2) 1.0 A SB FUSE. Protects output stage against overload conditions.



Schroff 09.25.89

