



**AVTECH ELECTROSYSTEMS LTD.**

NANOSECOND WAVEFORM ELECTRONICS  
SINCE 1975

P.O. BOX 265  
OGDENSBURG, NY  
U.S.A. 13669-0265  
TEL: (315) 472-5270  
FAX: (613) 226-2802

TEL: 1-800-265-6681  
FAX: 1-800-561-1970

e-mail: [info@avtechpulse.com](mailto:info@avtechpulse.com)  
<http://www.avtechpulse.com>

P.O. BOX 5120 STN. F  
OTTAWA, ONTARIO  
CANADA K2C 3H4  
TEL: (613) 226-5772  
FAX: (613) 226-2802

**INSTRUCTIONS**

**MODEL AVO-7D-C-OPA-OP1B-P**

**0 to 140 AMP, 0 to +70 V, 1  $\mu$ s RISE TIME  
LASER DIODE DRIVER  
WITH IEEE 488.2 AND RS-232 CONTROL**

**SERIAL NUMBER: \_\_\_\_\_**

### WARRANTY

Avtech Electrosystems Ltd. warrants products of its manufacture to be free from defects in material and workmanship under conditions of normal use. If, within one year after delivery to the original owner, and after prepaid return by the original owner, this Avtech product is found to be defective, Avtech shall at its option repair or replace said defective item. This warranty does not apply to units which have been disassembled, modified or subjected to conditions exceeding the applicable specifications or ratings. This warranty is the extent of the obligation assumed by Avtech with respect to this product and no other warranty or guarantee is either expressed or implied.

### TECHNICAL SUPPORT

Phone: 613-226-5772 or 1-800-265-6681

Fax: 613-226-2802 or 1-800-561-1970

E-mail: [info@avtechpulse.com](mailto:info@avtechpulse.com)

World Wide Web: <http://www.avtechpulse.com>

## TABLE OF CONTENTS

<b>WARRANTY</b>	<b>2</b>
<b>TECHNICAL SUPPORT</b>	<b>2</b>
<b>TABLE OF CONTENTS</b>	<b>3</b>
<b>INTRODUCTION</b>	<b>4</b>
<b>SPECIFICATIONS</b>	<b>6</b>
<b>INSTALLATION</b>	<b>7</b>
<b>VISUAL CHECK</b>	<b>7</b>
<b>PLUGGING IN THE INSTRUMENT</b>	<b>7</b>
<b>MAINFRAME FRONT PANEL CONTROLS</b>	<b>8</b>
<b>MAINFRAME REAR PANEL CONTROLS</b>	<b>10</b>
<b>OUTPUT MODULE CONTROLS</b>	<b>11</b>
<b>GENERAL INFORMATION</b>	<b>12</b>
<b>BASIC TEST ARRANGEMENT</b>	<b>12</b>
<b>LENZ'S LAW AND INDUCTIVE VOLTAGE SPIKES</b>	<b>13</b>
<b>BASIC PULSE CONTROL</b>	<b>13</b>
<b>MONITOR CIRCUIT</b>	<b>14</b>
<b>TRIGGER MODES</b>	<b>14</b>
<b>PULSE WIDTH MODES</b>	<b>15</b>
<b>GATING MODES</b>	<b>15</b>
<b>PROTECTION AGAINST INCORRECT USAGE</b>	<b>15</b>
<b>WATER COOLING</b>	<b>16</b>
<b>TOP COVER REMOVAL</b>	<b>17</b>
<b>RACK MOUNTING</b>	<b>17</b>
<b>START-UP CHECK-LIST FOR LOCAL CONTROL</b>	<b>18</b>
<b>PROGRAMMING YOUR PULSE GENERATOR</b>	<b>21</b>
<b>KEY PROGRAMMING COMMANDS</b>	<b>21</b>
<b>ALL PROGRAMMING COMMANDS</b>	<b>21</b>
<b>PERFORMANCE CHECK SHEET</b>	<b>23</b>

## INTRODUCTION

The Model AVO-7D-C-OPA-OP1B-P pulse generator is designed for pulsing laser diode and other low impedance loads with rectangular pulses as high as 140 Amperes into load voltages up to 70V, with 1  $\mu$ s rise and fall times. The pulse repetition frequency can vary from 0.1 to 5000 Hz, and pulse widths can vary from 10  $\mu$ s to 100  $\mu$ s. The maximum duty cycle is 5%.

The Model AVO-7D-C-OPA-OP1B-P pulse generator is a current pulser. The current amplitude is largely independent of the load voltage. The load voltage must not exceed 70V.

The AVO-7D-C-OPA-OP1B-P system consists of an instrument mainframe, an output module (the AVO-7D-OPA-P-PG) which connects to the mainframe via a 4 foot long detachable cable and a user-supplied high-current DC lab power supply. The load is connected to two banana connectors. The user-supplied high current DC lab power supply provides the prime power to the output module (see diagram below). The power supply must be set to  $V_{LOAD} + 20V$ , and it must be capable of supplying the average value (i.e.  $I_{DC}$ ) of the peak current supplied to the load ( $I_{LOAD}$ ).  $I_{DC}$ ,  $I_{LOAD}$ , pulse width (PW) and pulse period (T) are related as shown in the diagram. See the "Basic Test Arrangement" section for further details.

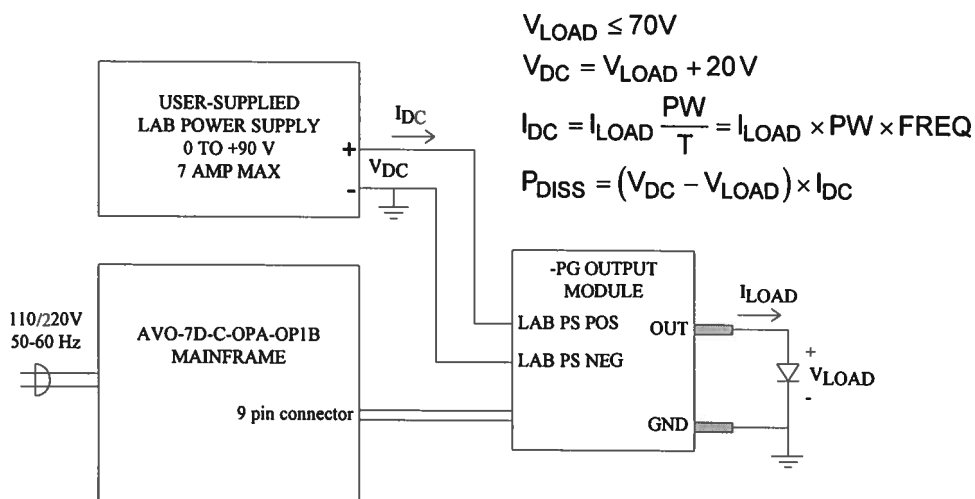

The AVO-7D-C-OPA-OP1B-P includes provision for water-cooling, which should be used when the power dissipated in the output module ( $P_{DISS}$ ) exceeds 30 Watts.

Protective circuits monitor the lab power supply voltage level and the output module temperature and will automatically disable the triggering of the output stage if either the applied voltage or temperature exceed rated values (+95V, +50°C).

A rear-panel BNC monitor output is available which provides an attenuated coincident replica of the main output current pulse. The front-panel display also shows the measured current amplitude, with an accuracy of  $\pm 2\% \pm 1A$ .

### SPECIFICATIONS

Model:	AVO-7D-C-OPA-OP1B-P
Amplitude:	0 to +140 Amperes, for load voltages of 0 to +70 Volts
Pulse width:	10 us to 100 us
Rise time:	≤ 1 us
Fall time:	≤ 1 us
PRF:	0.1 Hz to 5 kHz
Max. duty cycle:	5%
Output impedance:	≥ 10 Ohms
Max. average output current:	7 Amperes
Propagation delay:	≤ 100 ns (Ext trig in to pulse out)
Jitter:	± 500 ps (Ext trig in to pulse out)
Trigger required: (external trigger mode)	Internal PW Mode: +5 Volt, 50 ns or wider (TTL) External PW Mode: +5 Volt, $PW_{IN} = PW_{OUT}$ (TTL)
Monitor output:	Provides an attenuated coincident replica of the main output current pulse. $V_{MON} = I_{LOAD} \times 0.050 \Omega$
Sync delay:	Sync out to pulse out: Variable 0 to ± 200 us
Sync output:	+ 5 Volts, 200 ns, will drive 50 Ohm loads
Connectors:	Out: Two banana connectors Trig, Sync, Monitor: BNC DC Power: SUPERCON connectors (included)
Power, DC:	+20 to +90 V, 7 Amp max
Power, AC:	120/240 Volts (switchable) 50 - 60 Hz
Dimensions: (H x W x D)	Mainframe: 3.9" x 17" x 14.8" Output module: 6.5" x 9" x 8"
Chassis material:	anodized aluminum, with blue plastic trim
Mounting:	Any
Temperature range:	+ 10° to + 40° C
Pipe Thread:	1/4" NPT

## INSTALLATION

### VISUAL CHECK

After unpacking the instrument mainframe and the output module, examine to ensure that they have not been damaged in shipment. Visually inspect all connectors, knobs, liquid crystal displays (LCDs), and the handles. Confirm that a power cord and two instrumentation manuals (this manual and the "OP1B Interface Programming Manual") are with the instrument. If the instrument has been damaged, file a claim immediately with the company that transported the instrument.

### PLUGGING IN THE INSTRUMENT

Examine the rear of the instrument. There will be a male power receptacle, a fuse holder and the edge of the power selector card visible. Confirm that the power selector is in the correct orientation - it should be marked either 120 or 240, indicating whether it expects 120V AC or 240V AC. If it is not set for the proper voltage, remove the fuse and then grasp the card with a pair of pliers and remove it. Rotate horizontally through 180 degrees. Reinstall the card and the correct fuse. In the 120V setting, a 1.0A slow blow fuse is required. In the 240V setting, a 1/2A slow blow fuse is required.

**Note:** For first-time operation, rotate the "Contrast" knob on the front-panel fully clockwise.

## MAINFRAME FRONT PANEL CONTROLS

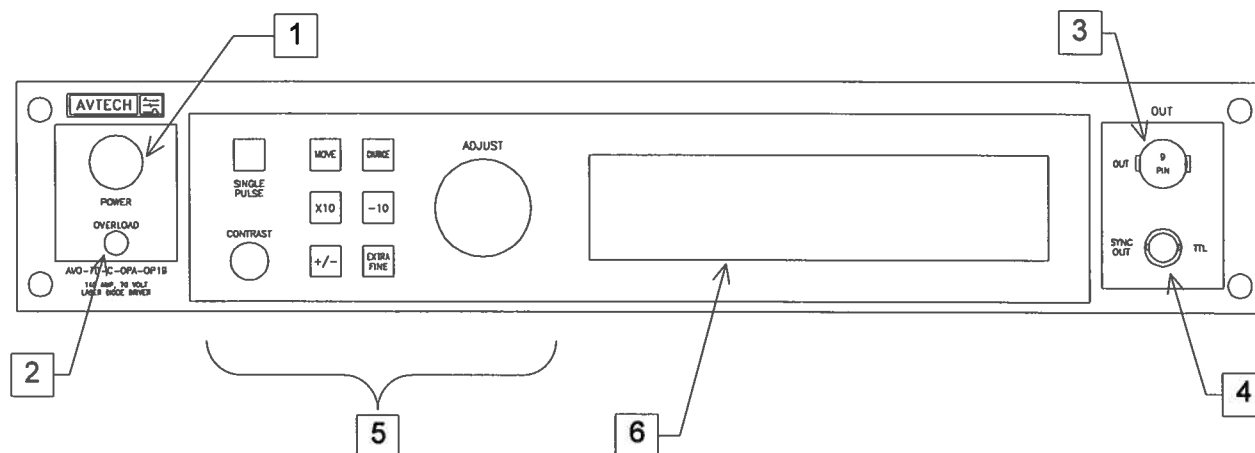

1. **POWER Switch.** The POWER push button switch applies AC prime power to the primaries of the transformer, turning the instrument on. The push button lamp (#382 type) is connected to the +15V DC supply.
2. **OVERLOAD.** An protective circuit controls the front panel overload light. This indicator will light if:
  - The instrument becomes excessively hot ( $\geq 50^{\circ}\text{C}$ )
  - The applied DC voltage exceeds 100V
  - The applied DC voltage is negative

The overload light may illuminate briefly when the AC power is first applied. If this indicator lights at any other time, the instrument should be turned off until the cause of the overload has been identified and corrected.
3. **OUT CONNECTOR.** This is a multi-pin connector which attaches the 4-foot-long, 9-pin cable from the pulse generator module to the mainframe.
4. **SYNC OUT.** This connector supplies a SYNC output that can be used to trigger other equipment, particularly oscilloscopes. This signal leads, or lags, the main output by a duration set by the "DELAY" controls and has an approximate amplitude of +3 Volts to  $R_L > 1\text{K}$  with a pulse width of approximately 200 ns.



5. KEYPAD.

Control Name	Function
MOVE	This moves the arrow pointer on the display.
CHANGE	This is used to enter the submenu, or to select the operating mode, pointed to by the arrow pointer.
×10	If one of the adjustable numeric parameters is displayed, this increases the setting by a factor of ten.
÷10	If one of the adjustable numeric parameters is displayed, this decreases the setting by a factor of ten.
+/-	If one of the adjustable numeric parameters is displayed, and this parameter can be both positive or negative, this changes the sign of the parameter.
EXTRA FINE	This changes the step size of the ADJUST knob. In the extra-fine mode, the step size is twenty times finer than in the normal mode. This button switches between the two step sizes.
ADJUST	This large knob adjusts the value of any displayed numeric adjustable values, such as frequency, pulse width, etc. The adjust step size is set by the "EXTRA FINE" button.  When the main menu is displayed, this knob can be used to move the arrow pointer.
CONTRAST	This adjusts the contrast of the display. Maximum contrast occurs when the knob is rotated fully clockwise.

6. LIQUID CRYSTAL DISPLAY (LCD). This LCD is used in conjunction with the keypad to change the instrument settings. Normally, the main menu is displayed, which lists the key adjustable parameters and their current values. The "OP1B Interface Programming Manual" describes the menus and submenus in detail.

## MAINFRAME REAR PANEL CONTROLS

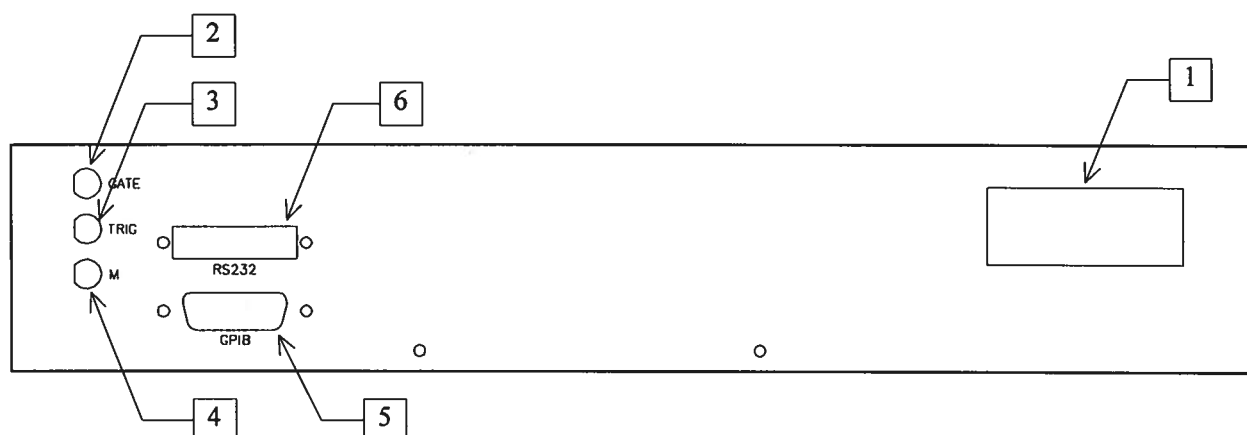

1. **AC POWER INPUT.** A three-pronged recessed male connector is provided on the back panel for AC power connection to the instrument. Also contained in this assembly is a 1.0A slow blow fuse and a removable card that can be removed and repositioned to switch between 120V AC in and 240V AC in.
2. **GATE.** This TTL-level (0 and +5V) logic input can be used to gate the triggering of the instrument. This input can be either active high or active low, depending on the front panel settings or programming commands. (The instrument triggers normally when this input is unconnected).
3. **TRIG.** This TTL-level (0 and +5V) logic input can be used to trigger the instrument, if the instrument is set to triggering externally. The instrument triggers on the rising edge of this input.
4. **M.** This is the current monitor output. This output provides a voltage waveform that is proportional to the current waveform on the main output. The monitor relationship is:  $V_{MON} = 0.05\Omega \times I_{OUT}$ , for a load of  $> 1\text{ k}\Omega$ , with an accuracy of  $\pm 2\% \pm 1\text{A}$ . (The monitor output can also drive a  $50\Omega$  load, but the output voltage will be reduced by a factor of two. This output is short-circuit protected.) The rise and fall times of the monitor output are slower than those of the main output. The monitor output has rise and fall times of approximately  $2\ \mu\text{s}$ .
5. **GPIB Connector.** A standard GPIB cable can be attached to this connector to allow the instrument to be computer-controlled. See the "OP1B Interface Programming Manual" for more details on GPIB control.
6. **RS-232 Connector.** A standard serial cable with a 25-pin male connector can be attached to this connector to allow the instrument to be computer-controlled. See the "OP1B Interface Programming Manual" for more details on RS-232 control.

## OUTPUT MODULE CONTROLS

1. S1 SWITCH. This switch should have three positions, marked 20V, 45V, and 70V. The switch should be set to the value that is closest to the maximum load voltage on the output. This setting is adjusted to reduce the output rise time and to obtain a flat top on the output current pulse.
2. P1, P2 Controls. Two ten-turn potentiometer controls, located above the output terminals, are used to set the accuracy of the output amplitude setting. The P2 pot is set at the factory and should not be changed. Adjustment of P1 should not be necessary provided the output module is dissipating less than 30 Watts or if the cooling water is near +25°C. If the cooling water temperature is substantially less than +25°C (e.g. +10°C) the monitor reading on the front panel LCD display will be higher than the amplitude setting. (This is caused by temperature sensitivity of the amplitude circuitry. The monitor circuit remains accurate.) The amplitude setting and the monitor reading can be brought into agreement by rotating P1 several turns clockwise. Conversely, if the water temperature is higher than +25°C, rotate the P1 pot several turns counterclockwise until the amplitude setting agrees with the monitor reading.

## GENERAL INFORMATION

### BASIC TEST ARRANGEMENT

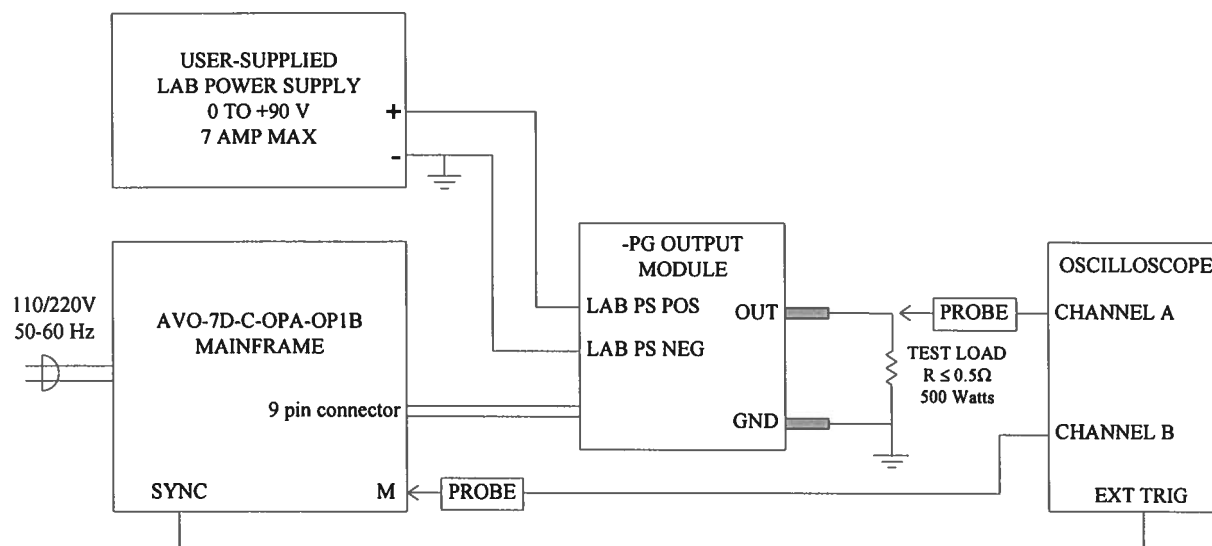

The equipment should be connected in the general fashion shown above.

The output module should always be connected to the mainframe BEFORE power is applied. The current monitor will not work properly otherwise.

The user supplied lab power supply attaches to the -PG output module via the red and black SUPERCON connectors which are supplied. The positive terminal of the power supply is to be connected to the RED SUPERCON connector on the -PG module. The negative terminal on the lab power supply is to be connected to ground and to the BLACK SUPERCON connector on the -PG module.

The output terminals of the pulse generator module are standard banana connectors.

It is essential that the resistive test load be low-inductance. (Wirewound resistors are not acceptable.) The power dissipated in the resistor is given by

$$P = I^2 \times R \times \frac{PW}{T},$$

where "I" is the current, "R" is the resistance, "PW" is the pulse width, and "T" is the pulse period (1/frequency).

The AVO-7D-C-OPA-OP1B-P includes provision for water-cooling, which should be used when the power dissipated in the output module ( $P_{DISS}$ ) exceeds 30 Watts.  $P_{DISS}$  can be calculated using:  $P_{DISS} = (V_{DC} - V_{LOAD}) \times I_{DC}$ .

### LENZ'S LAW AND INDUCTIVE VOLTAGE SPIKES

This instrument is designed to pulse resistive and diode loads and will exhibit a large output spike when used to drive a load with significant inductance (LENZ'S LAW). For this reason the load should be connected to the output using low inductance leads (as short as possible and as heavy a gauge as possible).

The voltage developed across an inductance L (in Henries), when the current is changing at a rate given by  $di_{LOAD}/dt$  (in Amps/sec), is:  $V_{SPIKE} = L \frac{di_{LOAD}}{dt}$ .

### BASIC PULSE CONTROL

This instrument can be triggered by its own internal clock or by an external TTL trigger signal. In either case, three output channels respond to the trigger: OUT, SYNC, and M. The OUT channel is the signal that is applied to the device under test. Its amplitude and pulse width are variable. The SYNC pulse is a fixed-width TTL-level reference pulse used to trigger oscilloscopes or other measurement systems. When the delay is set to a positive value the SYNC pulse precedes the OUT pulse. The M (Monitor) output is a voltage waveform that is proportional to the current waveform on OUT.

$V_{MON} = 0.05\Omega \times I_{OUT}$ , for a monitor load of  $> 1 \text{ k}\Omega$ . (The rise and fall times of the monitor output are slower than those of the main output. The monitor output has rise and fall times of approximately  $2 \mu\text{s}$ .)

These pulses are illustrated below:

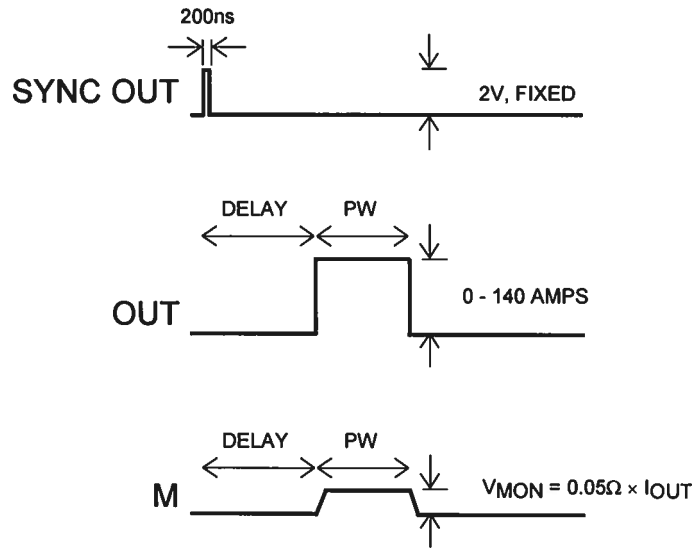

*Basic Output Pulses*

The delay, pulse width, and frequency (when in the internal mode), of the OUT pulse can be varied with front panel controls or via the GPIB or RS-232 computer interfaces.

The amplitude of the OUT pulse is controlled by the amplitude of the DC potential supplied to the SUPERCON connectors on the PG module. **CAUTION!! DO NOT EXCEED 100 VDC.**

### MONITOR CIRCUIT

As noted in the previous section, a current monitor output is available. The current monitor output also measures amplitude of the most recent pulse, in amperes, and displays it on the front panel LCD, with an accuracy of  $\pm 2\% \pm 1A$ . The value can also be read via the computer interface. The rise and fall times of the monitor output are slower than those of the main output. The monitor output has rise and fall times of approximately 2  $\mu s$ .

The output module should always be connected to the mainframe BEFORE power is applied. The current monitor will not work properly otherwise.

### TRIGGER MODES

This instrument has four trigger modes:

- Internal Trigger: the instrument controls the trigger frequency, and generates the clock internally.
- External Trigger: the instrument is triggered by an external TTL-level clock on the back-panel TRIG connector.
- Manual Trigger: the instrument is triggered by the front-panel "SINGLE PULSE" pushbutton.
- Hold Trigger: the instrument is set to not trigger at all.

These modes can be selected using the front panel trigger menu, or by using the appropriate programming commands. (See the "OP1B Interface Programming Manual" for more details.)

### PULSE WIDTH MODES

This instrument has two pulse width modes:

- Normal: the instrument controls the output pulse width.
- $PW_{IN}=PW_{OUT}$ : the output pulse width equals the pulse width of the trigger signal on the "TRIG" connector. The instrument must be in the external trigger mode.

These modes can be selected using the front panel pulse width menu, or by using the appropriate programming commands. (See the "OP1B Interface Programming Manual" for more details.)

### GATING MODES

Triggering can be suppressed by a TTL-level signal on the rear-panel GATE connector. The instrument can be set to stop triggering when this input high or low, using the front-panel gate menu or the appropriate programming commands. This input can also be set to act synchronously or asynchronously. When set to asynchronous mode, the GATE will disable the output immediately. Output pulses may be truncated. When set to synchronous mode, the output will complete the full pulse width if the output is high, and then stop triggering. No pulses are truncated in this mode.

### PROTECTION AGAINST INCORRECT USAGE

To avoid damaging the instrument, observe these rules:

- Never let the lab power supply voltage exceed 100V
- Never let the duty cycle exceed 5%
- Never let the peak output current exceed 140A
- Never let the average output current exceed 7A
- Set the DC power supply at  $V_{LOAD} + 20V$ . Higher voltages will cause extra heating.
- Use water-cooling when  $P_{DISS} = (V_{DC} - V_{LOAD}) \times I_{DC} > 30$  Watts, and maintain the cooling water temperature at  $+25^{\circ}C \pm 5^{\circ}C$ .

This pulse generator incorporates several features to protect against improper use. An protective circuit controls the front panel overload light and an internal buzzer. This indicator will light and the buzzer will sound if:

- The instrument becomes excessively hot
- The applied DC voltage exceeds 100V
- The applied DC voltage is negative

In these situations, triggering will be disabled.

The overload light may illuminate briefly when the AC power is first applied. If this indicator lights at any other time, the instrument should be turned off until the cause of the overload has been identified and corrected.

### WATER COOLING

The output module has provision for water cooling. (Thread size is 1/4" NPT.) This cooling is necessary when the power dissipated in the output module ( $P_{DISS}$ ) exceeds 30 Watts.  $P_{DISS}$  can be calculated using:  $P_{DISS} = (V_{DC} - V_{LOAD}) \times I_{DC}$ . The water requirement is approximately 5 litres/minute. If water cooling is not used, or if the water supply fails, the instrument will heat up until the automatic temperature-protection circuitry trips and disables the output until it has cooled. The cooling water should be maintained at  $+25^{\circ}C \pm 5^{\circ}C$ . If the cooling water temperature is substantially less than  $+25^{\circ}C$  (e.g.  $+10^{\circ}C$ ) the monitor reading on the front panel LCD display will be higher than the amplitude setting. (This is caused by temperature sensitivity of the amplitude circuitry. The monitor circuit remains accurate.) The amplitude setting and the monitor reading can be brought into agreement by rotating P1 several turns clockwise. Conversely, if the water temperature is higher than  $+25^{\circ}C$ , rotate the P1 pot several turns counterclockwise until the amplitude setting agrees with the monitor reading.



### TOP COVER REMOVAL

The top cover of the instrument may be removed by removing the four Phillips screws on the top panel. With these four screws removed, the top panel may be slid off by pulling it towards the rear.

### RACK MOUNTING

A rack mounting kit is available. The -R5 rack mount kit may be installed after first removing the one Phillips screw on the side panel adjacent to the front handle.

### START-UP CHECK-LIST FOR LOCAL CONTROL

- 1) The instruction manual has been studied thoroughly.
- 2) The "Local Control" section of the "OP1B Interface Programming Manual" has been studied thoroughly.
- 3) The -PG module is connected to the mainframe as shown in the "Basic Test Arrangement" section. (The output module should always be connected to the mainframe BEFORE power is applied. The current monitor will not work properly otherwise.)
- 4) If the power dissipated in the output module,  $P_{DISS} = (V_{DC} - V_{LOAD}) \times I_{DC}$ , will exceed 30 W, the water-cooling provisions of the output module should be used. (Thread size is 1/4" NPT.) A flow rate of 5 litres/minutes should be sufficient to cool the module. The cooling water should be maintained at  $+25^{\circ}\text{C} \pm 5^{\circ}\text{C}$ . If the cooling water temperature is substantially less than  $+25^{\circ}\text{C}$  (e.g.  $+10^{\circ}\text{C}$ ) the monitor reading on the front panel LCD display will be higher than the amplitude setting. (This is caused by temperature sensitivity of the amplitude circuitry. The monitor circuit remains accurate.) The amplitude setting and the monitor reading can be brought into agreement by rotating P1 several turns clockwise. Conversely, if the water temperature is higher than  $+25^{\circ}\text{C}$ , rotate the P1 pot several turns counterclockwise until the amplitude setting agrees with the monitor reading.
- 5) The load is connected to the output module. If the load is a diode, the anode of the load is connected to the OUT terminal. For initial testing, it is recommended that a resistive load be used. Factory tests are conducted using a 0.2 and 0.5 Ohm, 500 Watt resistive loads.
- 6) The user-supplied lab power supply is connected with the positive terminal connected to the red SUPERCON on the PG module and the negative terminal connected to the black SUPERCON. The negative terminal is grounded. The power supply potential is set to zero.
- 7) Turn on the prime power to the mainframe. The LCD will briefly display the message, "Nulling Current Monitor ....", and the main menu will appear. (If nothing appears, rotate the CONTRAST knob fully clockwise.)
- 8) The arrow pointer should be pointing at the frequency menu item. If it is not, press the MOVE button until it is.
- 9) Press the CHANGE button. The frequency submenu will appear. Rotate the ADJUST knob until the frequency is set at the desired setting. The arrow pointer

should be pointing at the "Internal" choice. If it is not, press MOVE until it is.

- 10) Press CHANGE to return to the main menu.
- 11) Press the MOVE button to move the arrow pointer to the pulse width menu item. Press CHANGE to bring up the pulse width submenu, and rotate the ADJUST knob until the pulse width is set at the desired setting. The arrow pointer should be pointing at the "Normal" choice. If it is not, press MOVE until it is. Press CHANGE to return to the main menu.
- 12) Connect the rear panel M output to the scope (1 VOLT/DIV) and connect the TRIG out to the scope time base. The scope time base should be triggering.
- 13) Connect a scope probe across the resistive test load and apply prime power to the lab power supply (after first ensuring that the output amplitude is set to zero).
- 14) Increase the lab power supply voltage to the desired value ( $V_{LOAD} + 20V$ ).
- 15) Set the S1 switch on the output module to the 20, 45, or 70 Volt position depending on the estimated peak load voltage.
- 16) Press the MOVE button to move the arrow pointer is pointing at the output item. Press CHANGE to bring up the output submenu. The arrow pointer should be initially be pointing at the "Output Off" choice. Press MOVE so that the arrow pointer is pointing at the "Output On" choice. (The mainframe is now supplying a trigger to the output module.) Press CHANGE to return to the main menu.
- 17) Press the MOVE button to move the arrow pointer to the amplitude menu item. Press CHANGE to bring up the amplitude submenu, and rotate the ADJUST knob until the amplitude is set at the desired setting. Observe the waveforms on the scope and the DC current level on the DC power supply. A rectangular pulse should appear on the scope (for both the load voltage and monitor channels) and the amplitude should increase as the ADJUST knob is rotated. At the same time, the average current supplied by the DC supply will increase.

The current monitor reading on the front panel LCD is accurate to within  $\pm 2\% \pm 1A$ . The current amplitude setting is accurate to within 5% ( $\pm 2A$ ) typically.

- 18) Observe the pulse width and pulse period on the scope and confirm that the duty cycle does not exceed 5% and that the peak current does not exceed 140 Amps (i.e. 7 Volts out from the monitor output).
- 19) Observe the DC current supplied by the DC supply and ensure that the average current does not exceed 7 Amperes.

20) Adjust pulse width, pulse period (i.e. PRF) and amplitude to obtain the desired settings. If necessary adjust pot P1 so that the amplitude setting agrees with the monitor reading.

21) If additional assistance is required:

Tel: (613) 226-5772, Fax: (613) 226-2802

Email: [info@avtechpulse.com](mailto:info@avtechpulse.com)

## PROGRAMMING YOUR PULSE GENERATOR

### KEY PROGRAMMING COMMANDS

The “OP1B Interface Programming Manual” describes in detail how to connect the pulse generator to your computer, and the programming commands themselves. A large number of commands are available; however, normally you will only need a few of these. Here is a basic sample sequence of commands that might be sent to the instrument after power-up:

```
*rst                (resets the instrument)
trigger:source internal (selects internal triggering)
frequency 100 Hz    (sets the frequency to 100 Hz)
pulse:width 100 us (sets the pulse width to 100 us)
pulse:delay 30 us  (sets the delay to 30 us)
output on          (turns on the output)
source:current 50 A (sets the current amplitude to 50 amperes)
measure:amplitude? (this returns the current amplitude, in amperes,
                   as measured by the monitor circuit)
```

These commands will satisfy 90% of your programming needs.

### ALL PROGRAMMING COMMANDS

For more advanced programmers, a complete list of the available commands is given below. These commands are described in detail in the “OP1B Interface Programming Manual”. (Note: this manual also includes some commands that are not implemented in this instrument. They can be ignored.)

<u>Keyword</u>	<u>Parameter</u>	<u>Notes</u>
LOCAL		
MEASure:		
:AMPLitude?		[query only]
OUTPut:		
:[STATe]	<boolean value>	
:PROTection		
:TRIPped?		[query only]
REMOTE		
[SOURce]:		
:FREQuency		
[:CW   FIXed]	<numeric value>	
[SOURce]:		
:CURRent		
[:LEVel]		
[:IMMediate]		
[:AMPLitude]	<numeric value>   EXTeRnal	
:PROTection		

	:TRIPped?	[query only]
[SOURCE]:		
	:PULSe	
	:PERiod	<numeric value>
	:WIDTh	<numeric value>
	:DCYClE	<numeric value>
	:HOLD	WIDTh   DCYClE
	:DELay	<numeric value>
	:GATE	
	:TYPE	ASYNc   SYNc
	:LEVel	HIGH   LOW
STATUS:		
	:OPERation	
	:[EVENt]?	[query only, always returns "0"]
	:CONDition?	[query only, always returns "0"]
	:ENABle	<numeric value> [implemented but not useful]
	:QUESTionable	
	:[EVENt]?	[query only, always returns "0"]
	:CONDition?	[query only, always returns "0"]
	:ENABle	<numeric value> [implemented but not useful]
SYSTEM:		
	:COMMunicate	
	:GPIB	
	:ADDRess	<numeric value>
	:SERial	
	:CONTRol	
	:RTS	ON   IBFull   RFR
	:[RECeive]	
	:BAUD	1200   2400   4800   9600
	:BITS	7   8
	:ECHO	<boolean value>
	:PARity	
	:[TYPE]	EVEN   ODD   NONE
	:SBITS	1   2
	:ERRor	
	:[NEXT]?	[query only]
	:COUNT?	[query only]
	:VERSion?	[query only]
TRIGger:		
	:SOURce	INTernal   EXTernal   MANual   HOLD   IMMEDIATE
*CLS		[no query form]
*ESE	<numeric value>	
*ESR?		[query only]
*IDN?		[query only]
*OPC		
*SAV	0   1   2   3	[no query form]
*RCL	0   1   2   3	[no query form]
*RST		[no query form]
*SRE	<numeric value>	
*STB?		[query only]
*TST?		[query only]
*WAI		[no query form]

PERFORMANCE CHECK SHEET

December 22/97

Michael did this set in Ward.

Edition A