



**AVTECH ELECTROSYSTEMS LTD.**

NANOSECOND WAVEFORM ELECTRONICS  
SINCE 1975

P.O. BOX 265  
OGDENSBURG, NY  
U.S.A. 13669-0265  
TEL: (315) 472-5270  
FAX: (613) 226-2802

TEL: 1-800-265-6681  
FAX: 1-800-561-1970  
U.S.A. & CANADA

e-mail: [info@avtechpulse.com](mailto:info@avtechpulse.com)

BOX 5120 STN. F  
OTTAWA, ONTARIO  
CANADA K2C 3H4  
TEL: (613) 226-5772  
FAX: (613) 226-2802

**INSTRUCTIONS**

**MODEL AVO-7F-C-PN-OP1 PULSE GENERATOR**

**S.N. :**

### WARRANTY

Avtech Electrosystems Ltd. warrants products of its manufacture to be free from defects in material and workmanship under conditions of normal use. If, within one year after delivery to the original owner, and after prepaid return by the original owner, this Avtech product is found to be defective, Avtech shall at its option repair or replace said defective item. This warranty does not apply to units which have been disassembled, modified or subjected to conditions exceeding the applicable specifications or ratings. This warranty is the extent of the obligation or liability assumed by Avtech with respect to this product and no other warranty or guarantee is either expressed or implied.

Fig. 1

PULSE GENERATOR TEST ARRANGEMENT

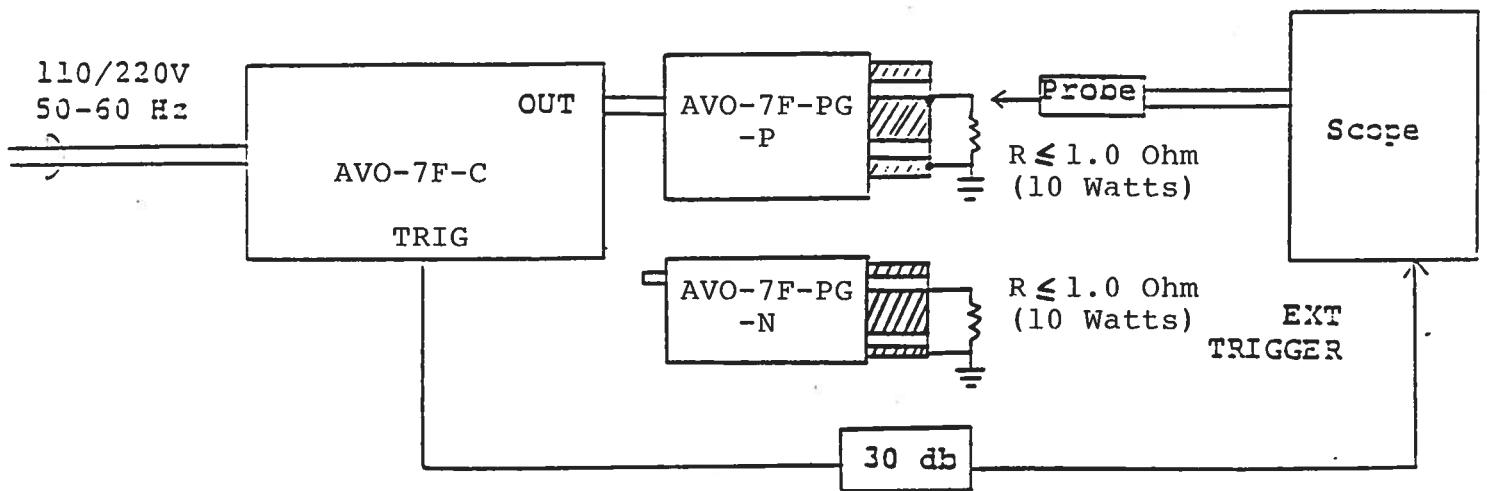

## Notes:

- 1) For front panel manual control of the output parameters, the rear panel LOCAL-REMOTE switch must be in the LOCAL position. For remote control using a personal computer, the switch should be in the REMOTE position. See the AN-101-AVO-7F section (at the end of the manual) for the instructions for this mode of operation. It is strongly recommended that the manual operation of the instrument be mastered before attempting the computer control operation.
- 2) The bandwidth capability of components and instruments used to display the pulse generator output signal (attenuators, cables, connectors, etc.) should exceed 100 MHz.
- 3) The TRIG output channel provides TTL level signals. To avoid overdriving the TRIG input channel of some scopes, a 30 dB attenuator should be placed at the input to the scope trigger channel. The TRIG output precedes the main output when the front panel ADVANCE-DELAY switch is in the ADVANCE position. The TRIG output lags the main output when the switch is in the DELAY position.
- 4) The desired output polarity is selected by means of the front panel POLARITY switch and by connecting the desired output module to the mainframe. The gray multi-pin cable must be plugged into the OUT connector and the black 50 Ohm RG50 cable connected between the HV BNC connector on the -PG module and the rear panel BNC HV connector on the mainframe.
- 5) To obtain a stable output display the PRF control on the front panel should be set mid-range. The front panel TRIG switch should be in the INT position. The DELAY controls and the scope triggering controls are then adjusted to obtain a stable output. The scope may then be used to set the desired PRF by rotating the PRF controls.
- 6) The output pulse width is controlled by means of the front panel one turn PW control (ten turn with -PWT option) and by the PW RANGE control. The minimum and maximum PW for each range and the corresponding maximum PRF are as follows. Note that the unit may fail if operated at duty cycles exceeding 50%.

	PW min	PW max
Range 1	1 us PRF max 1 kHz	10 us PRF max 1 kHz
Range 2	10 us PRF max 1 kHz	100 us PRF max 1 kHz
Range 3	100 us PRF max 1 kHz	1 ms PRF max 500 Hz

- 7) The output pulse amplitude is controlled by means of the front panel one turn AMP control.
- 8) An external clock may be used to control the output PRF of the AVO unit by setting the front panel TRIG toggle switch in the EXT position and applying a 50 ns (or wider) TTL level pulse to the TRIG BNC connector input. For operation in this mode, the scope time base must also be triggered by the external clock rather than from the TRIG output. When triggered externally, the output pulse width is controlled by the front panel PW controls provided the MODE A-B switch is in the A position. The MODE A-B switch is accessed by removing the top cover (by removing the four Phillips screws on the top panel and sliding the top cover back and off). When the MODE A-B switch is in the B position, the output pulse width equals the input trigger pulse width. The unit is shipped with the switch in the A position.
- 9) For single pulse manual operation, set the front panel INT-EXT-MAN switch in the MAN position and push the SINGLE PULSE button.
- 10) The DELAY control controls the relative delay between the reference output pulse provided at the TRIG output and the main output. This delay is variable over the range of 1 us to 1 ms. The TRIG output precedes the main output when the ADVANCE-DELAY switch is in the ADVANCE position and lags when the switch is in the DELAY position.

	MIN	MAX
Range 1	1.0 us	10 us
Range 2	10 us	100 us
Range 3	100 us	1 ms

- 11) The output terminals of the pulse generator module consists of a short length of microstrip transmission line protruding from the module chassis. The OUT terminal is the center conductor which is bounded on both sides by the ground plane (see below):

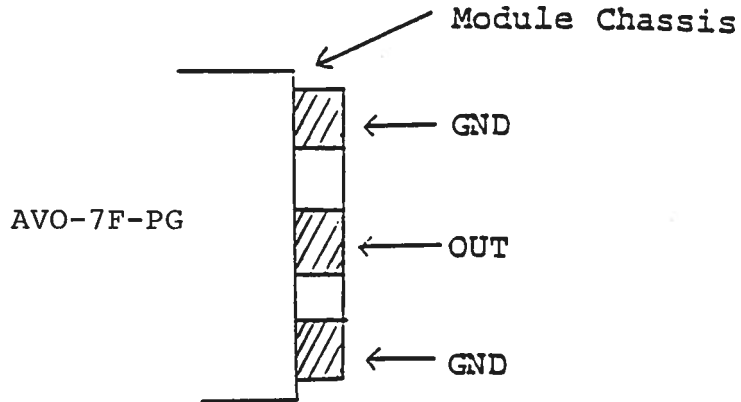

The load should be connected between the OUT and GND terminals using very short leads ( $\leq 1.0$  cm). The diode current may be monitored using a current probe or by placing a fractional Ohm resistor (eg. 0.1 Ohm) in series with the diode to ground and monitoring the voltage across the resistor. A fast diode (eg. 1N5819) should be placed across the laser diode load to protect against reverse potentials.

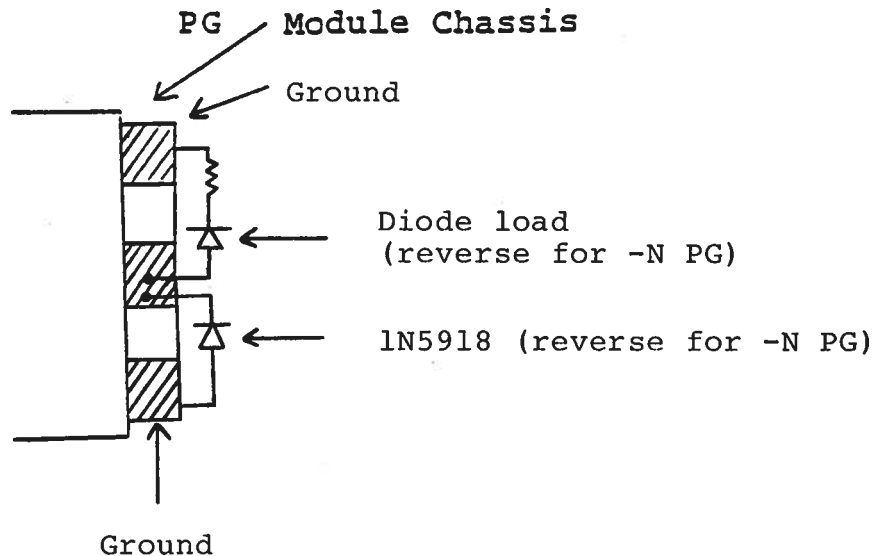

Take care to insure that during soldering the OUT conductor is not shorted to the chassis. Also, use minimal heat when soldering.

- 12) If the load cannot be placed directly on the output terminals of the -PG module, the AV-LZ lines should be used between the -PG module and the load (see AV-LZ data sheet).
- 13) The AVO-7F is designed to supply up to 5 Amperes to a maximum load voltage of 5 Volts. Factory tests are conducted with a 1.0 Ohm load capable of dissipating at least 10 Watts. Higher load resistance values may be used but the output voltage must be limited to 5 Volts or less.
- 14) CAUTION: The output stage is protected against overload condition by a 2.5 A slow blow fuse on the mainframe back panel. However, the output switching elements may fail if the 50% duty cycle rating is exceeded. Heating and subsequent likely failure of the output stage is reduced if the following action is taken where possible:
  - a) PRF is kept to a minimum, i.e. operate in the LOW PRF range when possible rather than in the HIGH range.
  - b) Keep the output PW to a minimum.
  - c) Keep the load resistance as high as possible.
- 15) AVO-7F units with a serial number higher than 5600 are protected by an automatic overload protective circuit which controls the front panel overload light. If the unit is overloaded (by operating at an exceedingly high duty cycle or by operating into a short circuit), the protective circuit will turn the output of the instrument OFF and turn the indicator light ON. The light will stay ON (i.e. output OFF) for about 5 seconds after which the instrument will attempt to turn ON (i.e. light OFF) for about 1 second. If the overload condition persists, the instrument will turn OFF again (i.e. light ON) for another 5 seconds. If the overload condition has been removed, the instrument will turn on and resume normal operation. Overload conditions may be removed by:
  - 1) Reducing PRF (i.e. switch to a lower range)
  - 2) Reducing pulse width (i.e. switch to a lower range)

16) MONITOR Option. The M output connector on the PG module provides a voltage pulse (to 50 Ohm or higher) where amplitude is proportional to the output peak load current. An output current of 5 Amperes provides a monitor voltage of 5.0 Volts.

17) The unit can be converted from 110 to 220V 50-60 Hz operation by adjusting the voltage selector card in the rear panel fused voltage selector cable connector assembly.

18) For additional assistance:

Tel: (613) 226-5772

Fax: (613) 226-2802



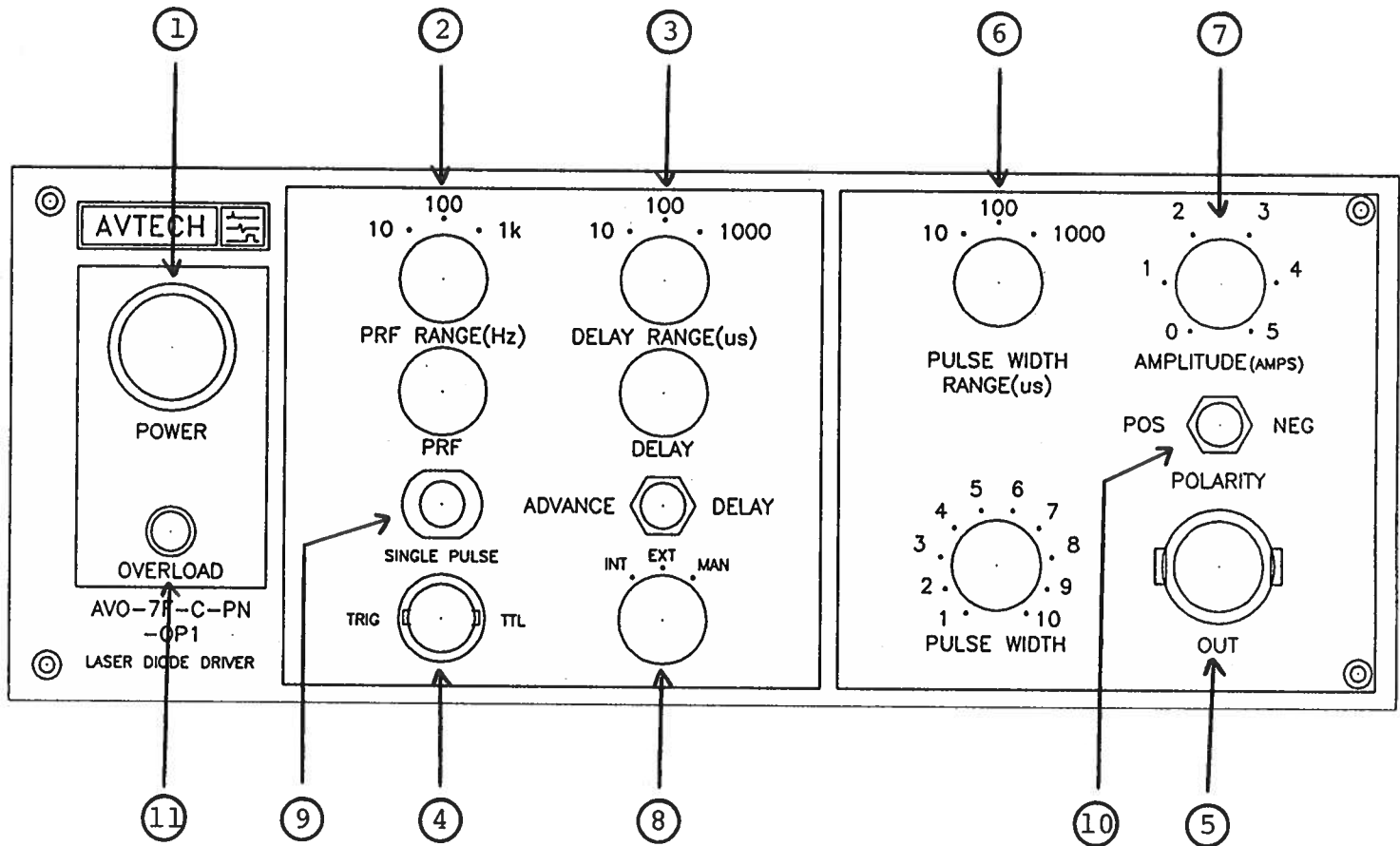

Fig. 2

FRONT PANEL CONTROLS

(1) ON-OFF Switch. Applies basic prime power to all stages.

(2) PRF Control. Varies PRF from 1 Hz to 1 kHz as follows:

1 Hz	to	10 Hz
10 Hz	to	100 Hz
100 Hz	to	1 kHz

(3) DELAY Control. Controls the relative delay between the reference output pulse provided at the TRIG output (4) and the main output (5). This delay is variable over the range of 0.1 to about 50 us. Delay LEADS or LAGS depending on the position of the ADVANCE-DELAY switch.

	MIN	MAX
Range 1	1 us	10 us
Range 2	10 us	100 us
Range 3	100 us	1 ms

(4) TRIG Output. This output is used to trigger the scope time base. The output is a TTL level 100 ns (approx.) pulse capable of driving a fifty Ohm load. This output precedes the output at (5) if the two position ADVANCE-DELAY switch is in the ADVANCE position. This output follows the output at (5) if the switch is in the DELAY position. The delay range is variable from 0.1 us to 50 us. The external trigger signal is applied at this input when the EXT-INT toggle switch is in the EXT position.

(5) OUT Connector. A multi pin connector which attaches the 2 foot gray multi-pin cable from the pulse generator module to the mainframe.

(6) PW Control. A one turn control (ten turn for -PWT option) and 3-position range switch which varies the output pulse width from 1 us to 1 ms. The minimum and maximum PW for each range and the corresponding maximum PRF are as follows. Note that the unit may fail if operated at duty cycles exceeding 50%.

	PW min	PW max
Range 1	1 us PRF max 1 kHz	10 us PRF max 1 kHz
Range 2	10 us PRF max 1 kHz	100 us PRF max 1 kHz
Range 3	100 us PRF max 1 kHz	1 ms PRF max 500 Hz

- (7) AMP Control. A one turn control (ten turn for -AT option) which varies the output pulse amplitude from 0 to 5 Amps (to  $R_L \leq 1 \text{ Ohm}$ ).
- (8) INT-EXT-MAN Control. With this toggle switch in the INT position, the PRF of the AVO unit is controlled via an internal clock which in turn is controlled by the PRF control. With the toggle switch in the EXT position, the AVO unit requires a 0.2 us TTL level pulse applied at the TRIG input in order to trigger the output stages. In addition, in this mode, the scope time base must be triggered by the external trigger source. When triggered externally, the output pulse width is controlled by the front panel PW controls provided the MODE A-B switch is in the A position. The MODE A-B switch is accessed by removing the top cover (by removing the four Phillips screws on the top panel and sliding the top cover back and off). When the MODE A-B switch is in the B position, the output pulse width equals the input trigger pulse width. The unit is shipped with the switch in the A position.
- (9) SINGLE PULSE. For single pulse manual operation, set the front panel INT-EXT-MAN switch in the MAN position and push the SINGLE PULSE button.
- (10) POLARITY. The desired output polarity is selected by means of the front panel POLARITY switch and by applying the desired output module to the OUT connector (5).

(11) OVERLOAD INDICATOR. AVO-7F-C units with a serial number higher than 5600 are protected by an automatic overload protective circuit which controls the front panel overload light. If the unit is overloaded (by operating at an exceedingly high duty cycle or by operating into a short circuit), the protective circuit will turn the output of the instrument OFF and turn the indicator light ON. The light will stay ON (i.e. output OFF) for about 5 seconds after which the instrument will attempt to turn ON (i.e. light OFF) for about 1 second. If the overload condition persists, the instrument will turn OFF again (i.e. light ON) for another 5 seconds. If the overload condition has been removed, the instrument will turn on and resume normal operation. Overload conditions may be removed by:

- 1) Reducing PRF (i.e. switch to a lower range)
- 2) Reducing pulse width (i.e. switch to a lower range)

Fig. 3

BACK PANEL CONTROLS

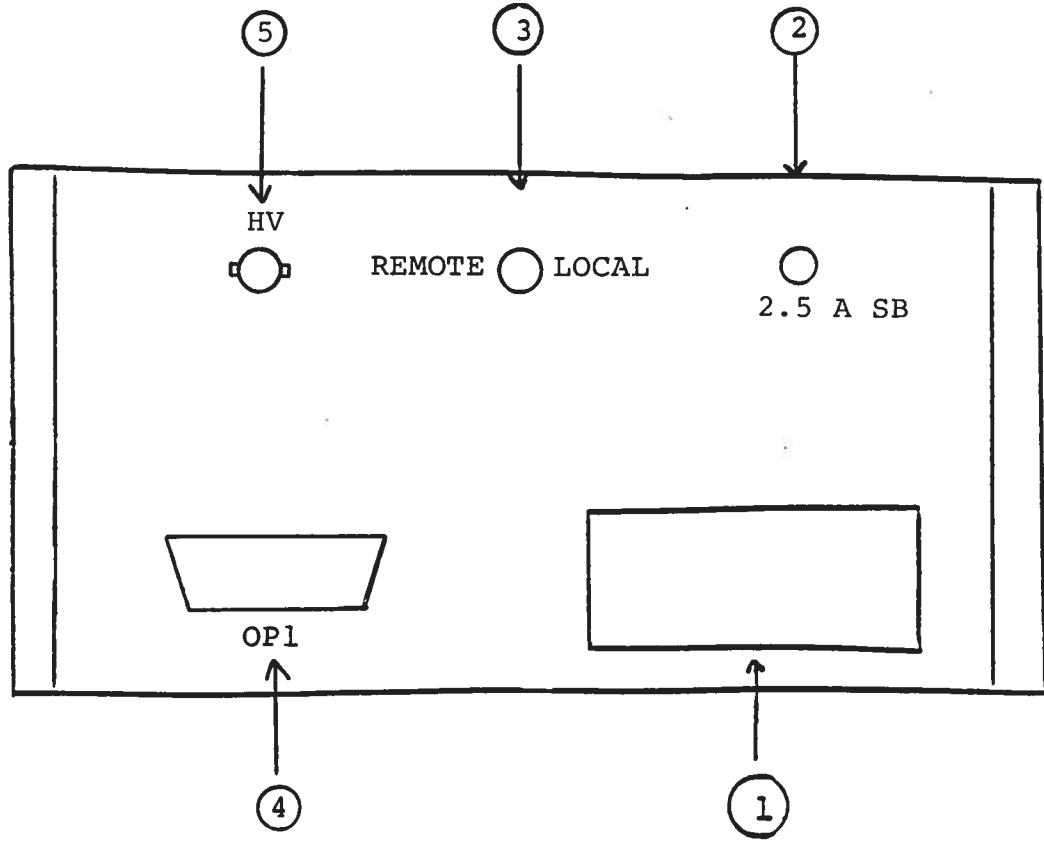

- (1) FUSED CONNECTOR, VOLTAGE SELECTOR. The detachable power cord is connected at this point. In addition, the removable cord is adjusted to select the desired input operating voltage. The unit also contains the main power fuse (0.5A SB).
- (2) 2.5A SB. Fuse which protects the output stage if the output duty cycle rating is exceeded.
- (3) LOCAL REMOTE SWITCH. This two-position switch must be in the LOCAL position to operate the instrument from the front panel controls. To control the instrument using your personal computer, the switch must be in the REMOTE position.
- (4) OP1 CONNECTOR. GPIB cable (supplied) connects between this connector and your personal computer.
- (5) HV BNC CONNECTOR. The black RG58 cable must be connected between this connector and the HV BNC connector on the output module.

## SYSTEM DESCRIPTION AND REPAIR PROCEDURE

The AVO-7F-C-PN-OP1 unit consists of the following basic modules:

- 1) AVO-7F-PG pulse generator module (positive and negative)
- 2) AVO-7F-C mainframe which includes:
  - a) OP12 PCB control board
  - b) AN-101 PCB control board
  - c)  $\pm 20$  Amp +24 Volt power supply PCB
  - d) 7F-OL-471 overload module
  - e) -7F-PS power supply module

The modules are interconnected as shown in Fig. 4.

In the event of an instrument malfunction, it is most likely that the 2.5A slow blow fuse or the main line fuse (0.5 Amp) on the rear panel has blown. Replace if necessary. If the unit still does not function, it is most likely that some of the output switching elements may have failed and the unit should be returned to the factory for repair.

# OP-1 Operating Instructions (AN-101-AVO-7F)

## 1.0 Introduction

This section describes how to use the OP-1 GPIB interface for remote computer control of the Avtech pulse generator, by means of the IEEE 488 General Purpose Interface Bus (GPIB).

The available commands and their structure, a typical command sequence and a sample program are included. In addition, possible methods of incorporating remote duty cycle limit checking and instructions on how to change the GPIB address are provided

## 2.0 Interface to the GPIB

The IEEE 488 compatible Bus functions available to the user for GPIB control are as follows: The listed functions define a listen-only capability:

- SH0, AH1, T0, TE0, L2, LE0, SR0, RL0, PP0, DC1, DT0, C0.

## 2.1 Available Commands

The OP-1 GPIB user interface is designed to be used to remotely program the Avtech pulse generator to control the pulse repetition rate, pulse width, pulse amplitude and delayed (or advanced) trigger output.

The available command acronyms, outputs, units and range of acceptable values for the AVO-7F-C-PN generator are defined in the table below:

Acronym	Output	Units	Range	Decades
I	I (current) amplitude	Amps	0 to 5	
R	Repetition rate	Hertz	1 to 1000	3
W	Width of pulse	micro-sec	1 to 1000	3
D	Delay (trigger)	micro-sec	1 to 1000	3
A	Advance (trigger)	micro-sec	1 to 1000	3



## 2.2 Command Interpretation

The command may utilize the defined single letter acronym, or may be expanded to a longer word to make the control program easier to understand. This is because letters following the defined acronym letter are ignored. For example, a command of "I=4.2" will result in exactly the same result if the command is sent as "I level of output pulse = 4.2". However, it is mandatory that the first letter of each command be one of the five defined acronyms.

Acronyms are case insensitive, for example, "R" or "r" are the same.

The number following the acronym letter may be any number in the range specified, however, the number of significant digits are limited to one part in 255 (for 8 bits of output resolution). For example, amplitude values of 12.82, 12.83 or 12.82145 will all result in the same output. (Note that output resolution and accuracy are not necessarily the same).

Leading or trailing zeros in numbers will be ignored.

Numbers expressed in "exponential" format will NOT be interpreted correctly. For example, 3e+2 will be interpreted as 3, not as 300.

The range of the specified values must be as specified for the equipment. Numbers outside the range will be ignored.

If desired, trailing text may be added to make the control program easier to understand, since it will be ignored. For example, a command of "width =77" will result in the same output as the command "width = 77 microseconds".

The term "Delay" is used to specify the duration of the delay between the trigger output pulse and the occurrence of the actual output pulse. The term "Advance" similarly refers to the amount of time the trigger pulse will occur prior to the output pulse.

If an invalid command is sent, the unit will ignore the command and the previous value will remain unchanged. If an "out-of-range" value is sent, the unit will also ignore the command.

## 2.3 Typical Command Sequence Interpretation

Assume the following commands are sent using the computer, using the appropriate command structure as specified for the user's GPIB controller. Note that the default GPIB address is eight.

```
R=100  
W=30  
I= 3  
A=10
```

## OP-1 Operating Instructions

For example, for a GPIB controller from National Instruments, the following set of commands would be sent:

```
ibwrt "r=100"  
ibwrt "w=30"  
ibwrt "i=3"  
ibwrt "a=10"
```

This command sequence will cause the generator to produce a series of output pulses of width 30 micro-sec and an amplitude of 3 amps peak, repeated at a rate of 100 pulses per second. An oscilloscope attached to the generator output will confirm the result. If the generator output trigger port is used, it will be noted that each output pulse will be delayed 10 micro-sec after the trigger pulse occurs.

### 2.4 Sample Program

To illustrate the remote control process by means of the GPIB, a sample program written in BASIC is provided. While this example is prepared for use with the B&C MicroSystems PC488 circuit card, the general principles of control apply to any IEEE 488 GPIB Controller.

```
'TEST of Pulser Controller  
OPEN "PC488" FOR OUTPUT AS #1  
PRINT #1, "ABORT"  
PRINT #1, "CLEAR"  
PRINT #1, "OUTPUT 8;I", 3  
PRINT #1, "OUTPUT 8;W", 30  
PRINT #1, "OUTPUT 8;R", 100  
PRINT #1, "OUTPUT 8;A", 10  
END
```

### 3.0 Duty Cycle Limits

Typically, Avtech pulse generators are limited to a maximum duty cycle because of thermal constraints, where duty cycle is the ratio of Pulse Width to the reciprocal of the Repetition Rate (i.e.;  $R \times W$ ). Although the generator contains automatic protection against an excessive duty cycle, whenever this protection is activated, the output is inhibited. Therefore, it may be desirable to have the control computer calculate the duty ratio, then generate a warning message to the operator whenever the limits are exceeded (preferably prior to actually sending the command sequence).

This message could caution the user either to reduce the repetition rate or the pulse width, to avoid thermal overload.

While this calculation is not mandatory, it could avoid the annoyance of automatic inhibiting of the generator output.

## OP-1 Operating Instructions

### 4.0 Changing the Unit GPIB Address

Since the GPIB data bus address for the pulse generator has been preset to "8" in the factory, commands are required to be sent to this address. However, the user may wish to change the address to any address in the allowed range of 0 to 30. This address may be easily changed by re-setting the GPIB address switch on the GPIB Interface board located inside the pulse generator chassis.

The address is set by means of a five position "Dipswitch " located on the top of a small circuit card located inside the enclosure near the top rear. The switch may observed to be set to the default address by noting that the Dipswitch position 4 is set in the OFF position, defining a binary address of 8.

The switch setting is calculated as the sum of the switch weights in the OFF position, calculated as follows: (a switch in the ON position it has a weight of zero):

Switch Number	OFF Weight
1	1
2	2
3	4
4	8
5	16

For example, a switch with positions 1, 4 and 5 set to OFF will result in an address setting of 25 (16 plus 8 plus 1 = 25).

### 5.0 Trouble-Shooting Aid

In the event that difficulties are encountered communicating via the GPIB interface, two auxiliary communications status indicators have been included on the GPIB interface circuit card. These status indicators are small LED lamps, one which flashes briefly whenever a properly addressed command is received. The second LED will light whenever an out-of-range value or invalid command is received, and will remain lit until a valid command with a valid in-range value is subsequently received.

OP-1 List

**List of Avtech products which include the OP-1 option.**

The supplied command acronyms, outputs, units and range of values are:

Acronym	Output	Units	Range	Decades
<b>1. AVL-2C (E/D 101 Rev 1)</b>				
V	Voltage amplitude	Volts	0 to 350	
R	Repetition rate	Hertz	5 to 5000	3
W	Width of pulse	micro-sec	5 to 500	2
D	Delay (trigger)	nano-sec	20 to 200	1
A	Advance (trigger)	nano-sec	20 to 200	1
<b>2. AVL-AV-C (E/D 101 Rev 2)</b>				
V	Voltage amplitude	Volts	0 to 250	
R	Repetition rate	Hertz	5 to 5000	3
W	Width of pulse	nano-sec	10 to 100	1
D	Delay (trigger)	nano-sec	25 to 250	1
A	Advance (trigger)	nano-sec	25 to 250	1
<b>3. AVO-5D (E/D 101 Rev 3)</b>				
I	I (current) amplitude	Amps	0 to 30	
R	Repetition rate	Hertz	3 to 300	2
W	Width of pulse	micro-sec	0.05 to 5	2
D	Delay (trigger)	micro-sec	0.05 to 5	2
A	Advance (trigger)	micro-sec	0.05 to 5	2
<b>4. AV-1011-C (E/D 101 Rev 4 and E/D 101 Rev 5, Note: Qty 2 delivered)</b>				
V	Voltage amplitude	Volts	0 to 100	
R	Repetition rate	Hertz	1 to 1000000	4
W	Width of pulse	micro-sec	0.1 to 100	3
D	Delay (trigger)	micro-sec	0.1 to 100	3
A	Advance (trigger)	micro-sec	0.1 to 100	3
P	Polarity		+ or -	
<b>5. AV-6C1-C (E/D 101 Rev 6)</b>				
I	I (current) amplitude	Amps	0 to 5	
R	Repetition rate	Hertz	1 to 10000	4
W	Width of pulse	micro-sec	0.05 to 50	3
D	Delay (trigger)	micro-sec	0.05 to 50	3
A	Advance (trigger)	micro-sec	0.05 to 50	3
<b>7. AVO-7F-C-PN (E/D 101 Rev 7)</b>				
I	I (current) amplitude	Amps	0 to 5	
R	Repetition rate	Hertz	1 to 1000	3
W	Width of pulse	micro-sec	1 to 1000	3
D	Delay (trigger)	micro-sec	1 to 1000	3
A	Advance (trigger)	micro-sec	1 to 1000	3

April 9/96

-PWT

Disk: AVO-7F

-M

Name: 7FCPNOP1.INS