



# AVTECH ELECTROSYSTEMS LTD.

NANOSECOND WAVEFORM ELECTRONICS  
SINCE 1975

□ P.O. BOX 265  
OGDENSBURG, NY  
U.S.A. 13669-0265  
TEL: (315) 472-5270  
FAX: (613) 226-2802

TEL: 1-800-265-6681  
FAX: 1-800-561-1970

e-mail: [info@avtechpulse.com](mailto:info@avtechpulse.com)  
<http://www.avtechpulse.com>

□ P.O. BOX 5120 STN. F  
OTTAWA, ONTARIO  
CANADA K2C 3H4  
TEL: (613) 226-5772  
FAX: (613) 226-2802

## INSTRUCTIONS

### MODEL AVO-8C-C PULSE GENERATOR

S.N.:

### WARRANTY

Avtech Electrosystems Ltd. warrants products of its manufacture to be free from defects in material and workmanship under conditions of normal use. If, within one year after delivery to the original owner, and after prepaid return by the original owner, this Avtech product is found to be defective, Avtech shall at its option repair or replace said defective item. This warranty does not apply to units which have been disassembled, modified or subjected to conditions exceeding the applicable specifications or ratings. This warranty is the extent of the obligation assumed by Avtech with respect to this product and no other warranty or guarantee is either expressed or implied.

### TECHNICAL SUPPORT

Phone: 613-226-5772 or 1-800-265-6681

Fax: 613-226-2802 or 1-800-561-1970

E-mail: [info@avtechpulse.com](mailto:info@avtechpulse.com)

World Wide Web: <http://www.avtechpulse.com>

TABLE OF CONTENTS

WARRANTY .....	2
TABLE OF CONTENTS .....	3
FIG. 1: PULSE GENERATOR TEST ARRANGEMENT .....	4
GENERAL OPERATING INSTRUCTIONS .....	5
Fig. 2: FRONT PANEL CONTROLS .....	9
FRONT PANEL CONTROLS .....	10
FIG 3: BACK PANEL CONTROLS .....	12
BACK PANEL CONTROLS .....	13
AVO-8-C BLOCK DIAGRAM .....	14
SYSTEM BLOCK DIAGRAM .....	15
START-UP CHECK LIST .....	16
PERFORMANCE CHECK .....	18

FIG. 1: PULSE GENERATOR TEST ARRANGEMENT

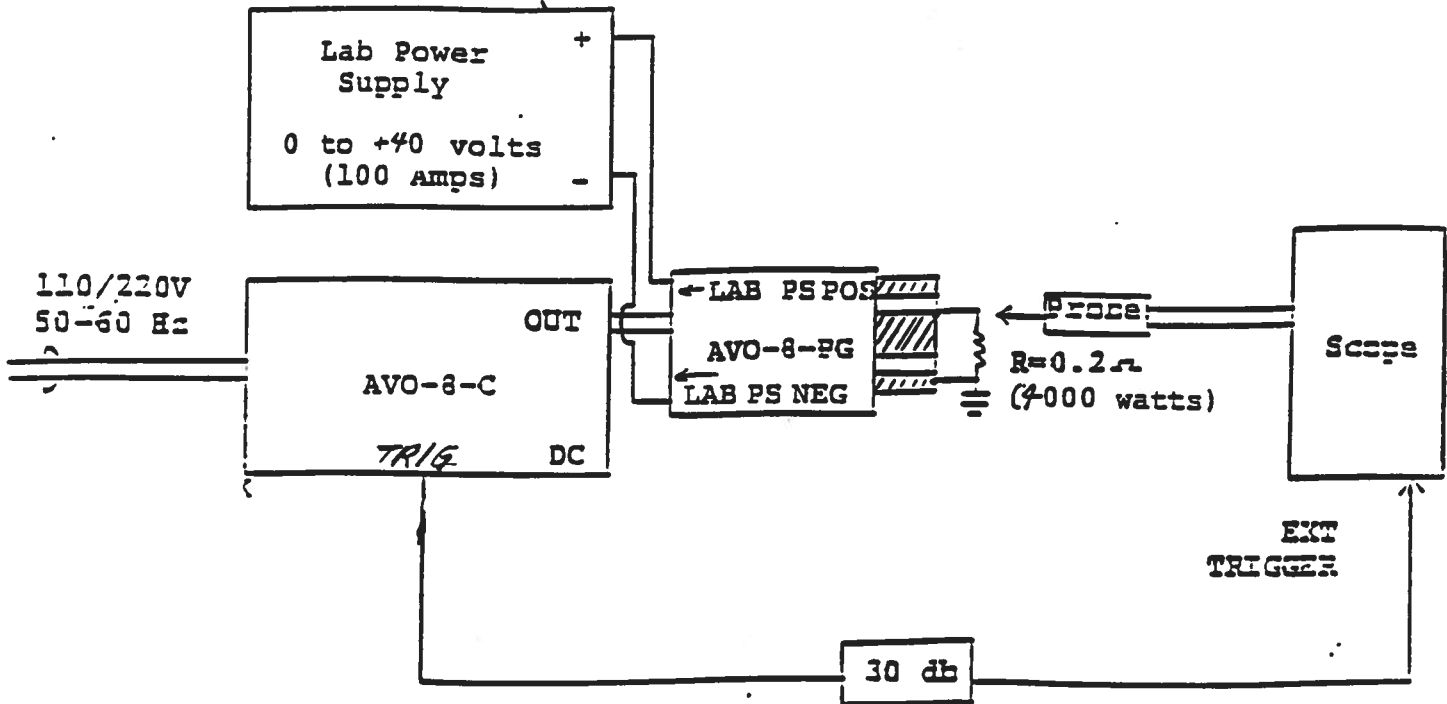

## GENERAL OPERATING INSTRUCTIONS

- 1) The equipment should be connected in the general fashion shown above. Since the AVO unit provides an output pulse rise time as low as 0.1  $\mu$ s a fast oscilloscope (at least 50 MHz) should be used to display the waveform.
- 2) The user supplied lab power supply attaches to the -PG output module via the red and black SUPERCON connectors which are supplied. The positive terminal of the power supply is to be connected to the RED SUPERCON connector on the -PG module. The negative terminal on the lab power supply is to be connected to the BLACK SUPERCON connector on the -PG module. For a -P unit, the negative terminal on the lab power supply must be grounded while for a -N unit the positive terminal must be grounded.
- 3) The output module (-PG) must be connected to the mainframe via the RS232 style gray cable (which mates to the OUT connector on the mainframe rear panel).
- 4) The trig output channel provides TTL level signals. To avoid overdriving the TRIG input channel of some scopes, a 30 db attenuator should be placed at the input to the scope trigger channel. The TRIG output precedes the main output when the front panel ADVANCE-DELAY switch is in the ADVANCE position. The TRIG output lags the main output when the switch is in the DELAY position.
- 5) To obtain a stable output display the PW and PRF controls on the front panel should be set mid-range. The front panel INT-EXT-MAN-DC switch should be in the INT position. The DELAY controls and the scope triggering controls are then adjusted to obtain a stable output. The scope may then be used to set the desired PRF by rotating the PRF controls.
- 6) The output terminals of the pulse generator module consists of a short length of microstrip transmission line protruding from the module chassis. The OUT terminal is the center conductor which is bounded on both sides by the ground plane (see below). Note that the "OUT" red banana terminal is in parallel with the microstrip center conductor and so may also be used as the output terminal.

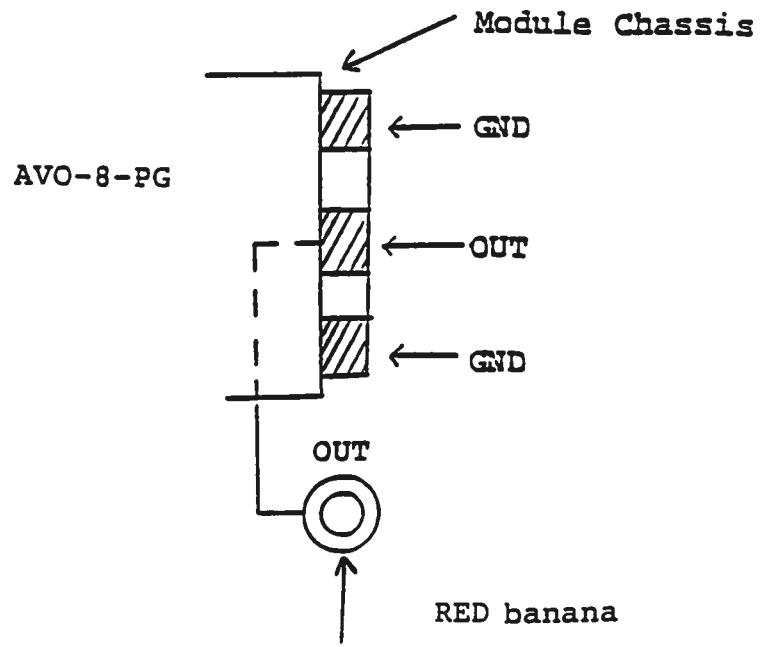

The load should be connected between the OUT and GND terminals using very short leads ( $\leq 2.0$  cm).

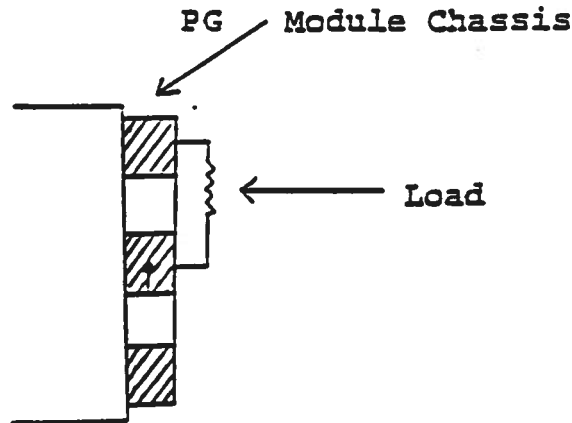

Take care to insure that during soldering the OUT conductor is not shorted to the chassis. Also, use minimal heat when soldering.

- 7) When the PW MODE switch is in the INT position, the output pulse width is controlled by the 4 position range switch and one turn fine control. To voltage control the output pulse width within each range, set the rear panel switch in the EXT position and apply 0 to +10 volts between terminal A and ground ( $R_{IN} \geq 10K$ ). (option). (See (9) for PW control when the PW MODE switch is in the EXT position).
- 8) The output amplitude is controlled by the amplitude of the DC potential supplied to the SUPERCON connectors on the PG module.
- 9) An external clock may be used to control the output PRF of the unit by setting the front panel INT-EXT-MAN-DC switch in the EXT position and applying a 0.2 us (approx) TTL level pulse to the TRIG BNC connector input. The external clock may also be used to control the output pulse width by setting the PW mode switch in the EXT position (in this case,  $PW_{OUT} = PW_{IN}$ ).

- 10) The AVO-8C is designed to supply up to 200 amperes peak to a maximum load voltage of 40 volts. Factory tests are conducted with a 0.2 ohm load capable of dissipating at least 4000 watts. Higher load resistance values may be used but the input voltage must be limited to 40 volts or less. Note that the unit may fail if the average output current exceeds 100 Amp.
- 11) Model AVO-8C will operate with a duty cycle at least as high as 85% when the pulse width is controlled by the front panel Pulse Width and Pulse Width Range controls. A duty cycle of 100% is obtained by setting the pulse width mode switch in the DC position. In this position the PW controls are no longer active. In this position the load voltage will be about 1.5 volts less than the applied DC voltage for a load current of 100 amperes. Note that the average output current must never exceed 100 Amp.
- 12) The unit can be converted from 110 to 220V 50-60 Hz operation by adjusting the voltage selector card in the rear panel fused voltage selector cable connector assembly.
- 13) The rear panel monitor output BNC (M) provides an output voltage (to 50 ohms or higher) which is proportional to the current flowing through the microstrip output terminals ( $500 \text{ mV} \approx 200 \text{ Amps}$ ). Note that the monitor function is not connected to the banana output terminals (option).
- 14) If application assistance is required:

Tel: (613) 226-5772

Fax: (613) 226-2802



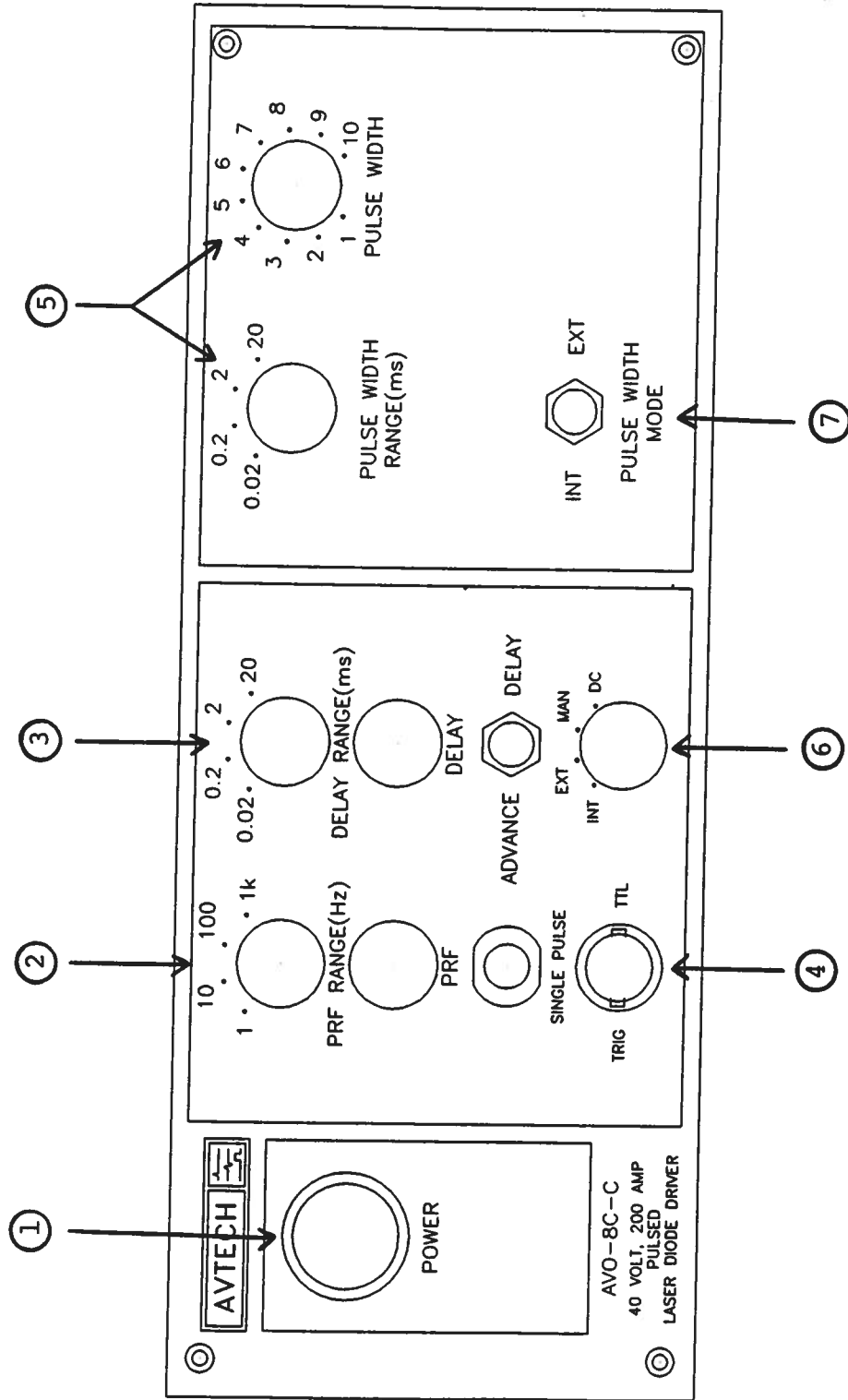

FRONT PANEL CONTROLS

Fig. 2

## FRONT PANEL CONTROLS

- (1) ON-OFF Switch. Applies basic prime power to all stages.
- (2) PRF Control. Varies PRF from 10 Hz to 5 kHz as follows:
- |         |                  |
|---------|------------------|
| Range 1 | 0.1 Hz to 1 Hz   |
| Range 2 | 1 Hz to 10 Hz    |
| Range 3 | 10 Hz to 0.1 kHz |
| Range 4 | 0.1 kHz to 1 kHz |
- (3) DELAY Control. Controls the relative delay between the reference output pulse provided at the TRIG output (4) and the -PG output. This delay is variable as follows:
- |         |                 |
|---------|-----------------|
| Range 1 | 2 us to 20 us   |
| Range 2 | 20 us to 200 us |
| Range 3 | 200 us to 2 ms  |
| Range 4 | 2 ms to 20 ms   |
- The TRIG output precedes the main output when the ADVANCE-DELAY switch is in the ADVANCE position and lags when the switch is in the DELAY position.
- (4) TRIG Output. This output is used to trigger the scope time base. The output is a TTL level 100 ns (approx.) pulse capable of driving a fifty ohm load.
- (5) PW Control. A one turn control and four position range switch which varies the output pulse width as follows (when the PW MODE switch is in the INT mode):
- |         |                 |
|---------|-----------------|
| Range 1 | 2.0 us to 20 us |
| Range 2 | 20 us to 200 us |
| Range 3 | 200 us to 2 ms  |
| Range 4 | 2 ms to 20 ms   |
- (6) EXT-INT Control. With this toggle switch in the INT position, the PRF of the AVO unit is controlled via an internal clock which in turn is controlled by the PRF controls. With the toggle switch in the EXT position, the AVO unit requires a 0.2 us TTL level pulse applied at the TRIG input in order to trigger the output stages. In addition, in this mode, the scope time base must be triggered by the external trigger source. For single pulse operation, place the switch in the MAN position and push the single pulse button. For DC operation

- (ie 100% duty cycle) place the switch in the DC position.
- 7) PW MODE. With the MODE switch in the INT position the PW is controlled by the front panel controls whether the unit is triggered internally or externally. When the switch is in the EXT position, the PW is controlled by the TTL PW applied externally to the TRIG input. Model AVO-8C-C will operate with a duty cycle at least as high as 85% when the PW MODE switch is in the INT position and the pulse is controlled by the front panel Pulse Width and Pulse Width Range controls. A duty cycle of 100% is obtained by setting the INT-EXT-MAN-DC switch in the DC position. In this position the PW controls are no longer active. In this position the load voltage will be about 1.5 volts less than the applied DC voltage for a load current of 100 amperes.

FIG 3: BACK PANEL CONTROLS

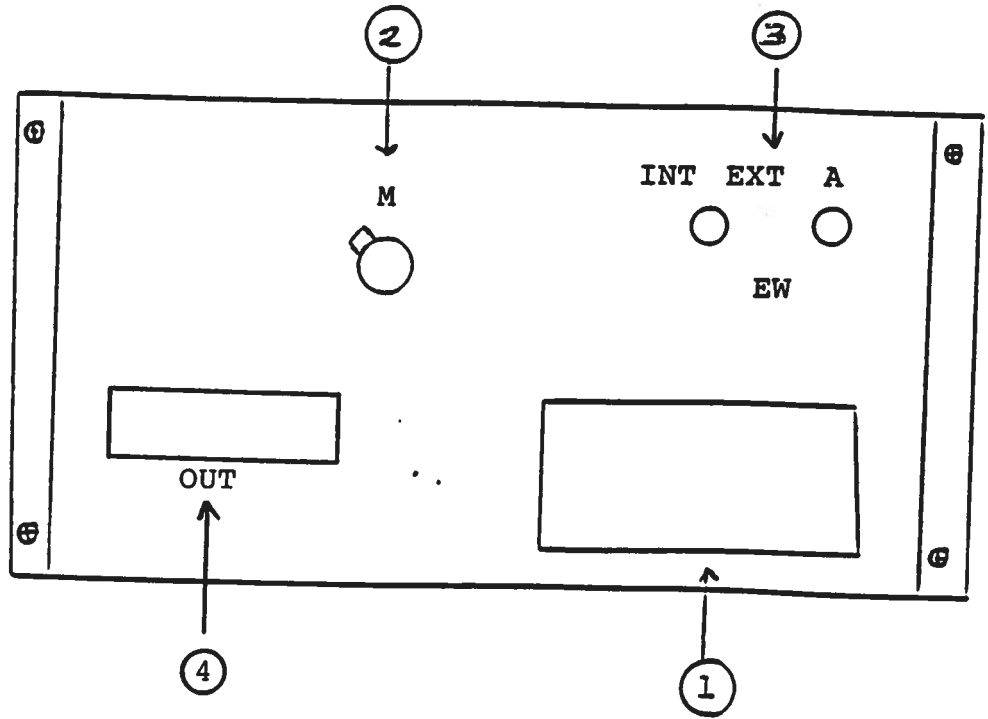

## BACK PANEL CONTROLS

- (1) FUSED CONNECTOR, VOLTAGE SELECTOR. The detachable power cord is connected at this point. In addition, the removable cord is adjusted to select the desired input operating voltage. The unit also contains the main power fuse (0.5 A SB).
- (2) M OUT. BNC connector provides output voltage (to  $R_L \geq 50$  Ohms) which is proportional to load current through the banana output terminals (500 mV  $\approx$  200 Amp). (option).
- (3) EW. To voltage control the output pulse width, set the switch in the EXT position and apply 0 to +10 volts between terminal A and ground ( $R_{IN} > 10K$ ). (option).
- (4) OUT. The gray RS232 style cable from the output module connects to this connector.

AVO-8-C BLOCK DIAGRAM

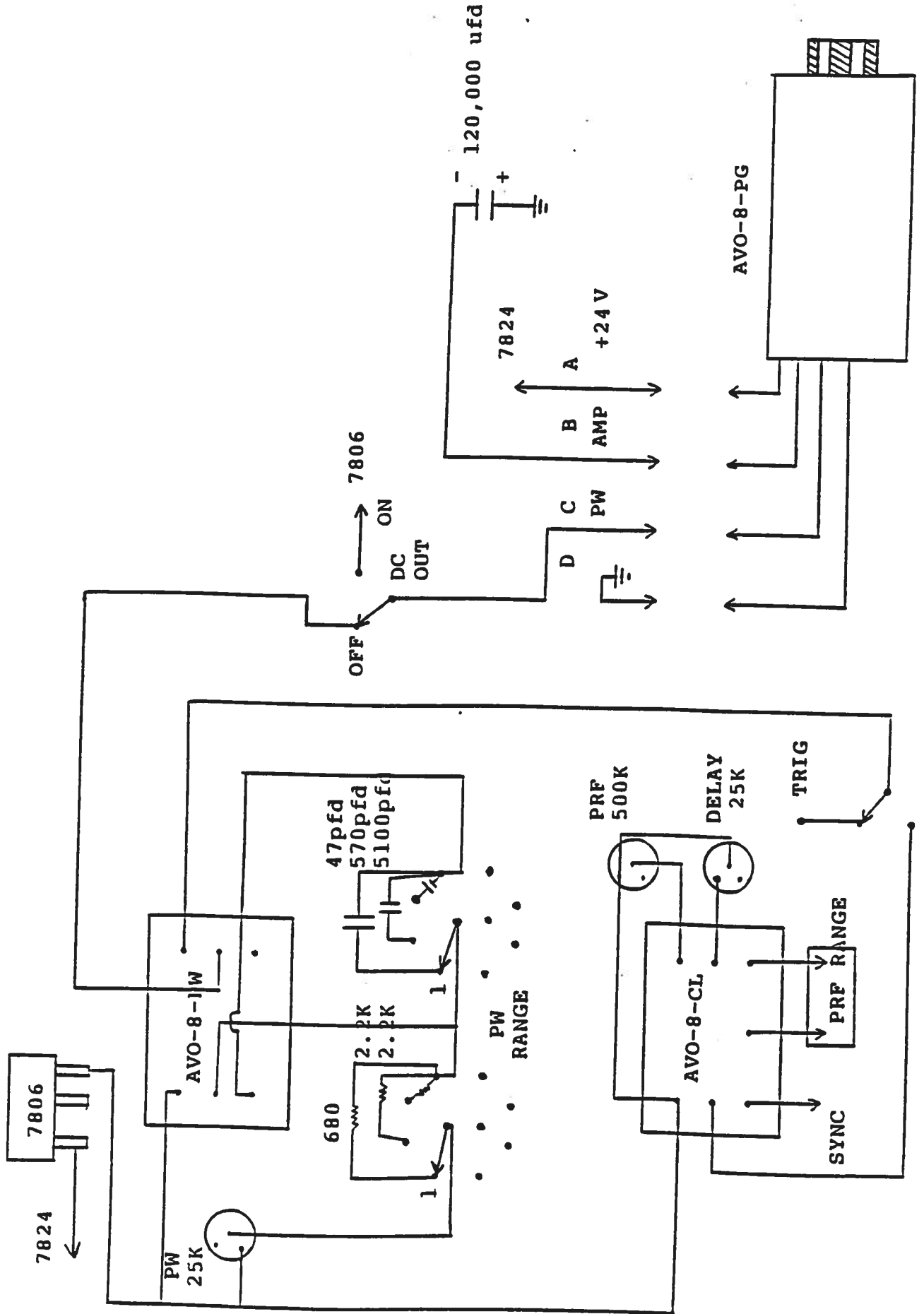

SYSTEM BLOCK DIAGRAM

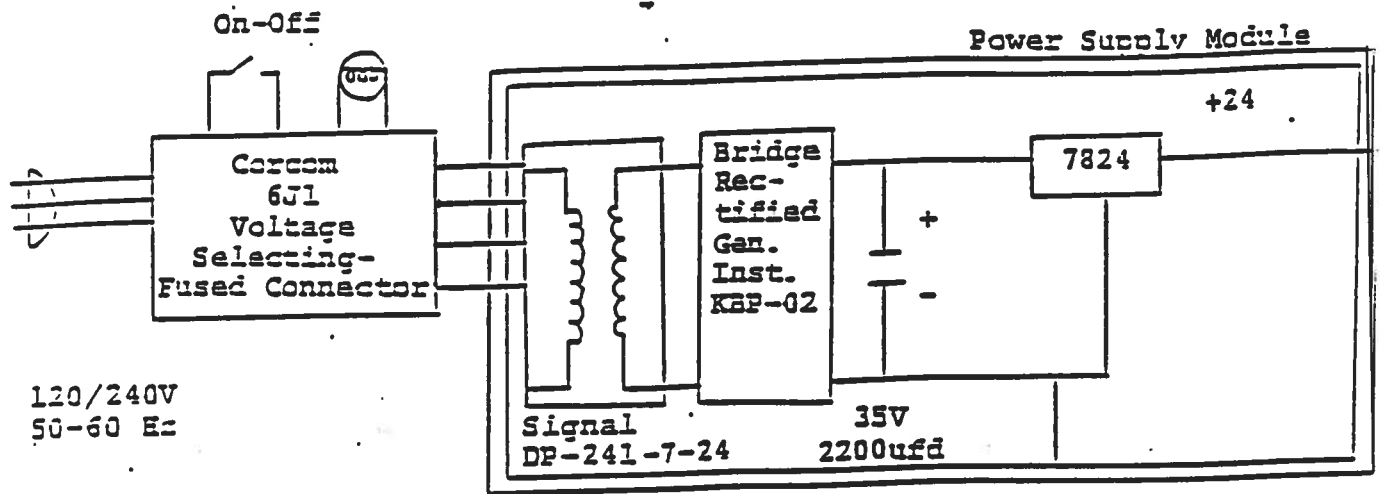

## START-UP CHECK LIST

- 1) The instruction manual has been studied thoroughly.
- 2) The -PG module is connected to the mainframe.
- 3) The load is connected to the output module. If the load is a diode, the anode of the load is connected to the OUT terminal for -P units while for -N units the cathode is connected to the OUT terminal. Note that with a diode load, a current limiting high power resistor must be placed in series with the diode to help limit the peak current. For initial testing, it is recommended that a resistive load be used. Factory tests are conducted using a 0.2 Ohm 4000 Watt resistive load.
- 4) The user-supplied lab power supply is connected with the positive terminal connected to the red SUPERCON on the PG module and the negative terminal connected to the black SUPERCON. The negative terminal is grounded for -P units while the positive terminal is grounded for -N units. The power supply potential is set to zero.
- 5) Set the mainframe pulse width and PRF controls at the approximate desired values (while insuring that the duty cycle is less than 10%).
- 6) Set the INT-EXT switch on INT.
- 7) Connect the rear panel M output to the scope (1 VOLT/DIV) and connect the TRIG out to the scope time base (option).
- 8) Turn on the prime power to the mainframe. The scope time base should be triggering.
- 9) Connect a scope probe across the resistive test load and apply prime power to the lab power supply (after first insuring that the output amplitude is set to zero).
- 10) Gradually increase the output amplitude on the lab power supply and observe the waveforms on the scope and the DC current level on the DC power supply. A rectangular pulse should appear on the scope (for both the load voltage and monitor channels) and the amplitude should increase as the amplitude control on the mainframe is rotated clockwise. At the same time, the average current supplied by the DC supply will increase.



- 11) Observe the pulse width and pulse period on the scope and confirm that the duty cycle does not exceed 10% and that the peak current does not exceed 200 Amps.
- 12) Observe the DC current supplied by the DC supply and insure that the average current does not exceed 100 Amperes.
- 13) Adjust pulse width, pulse period (i.e. PRF) and amplitude to obtain the desired settings.
- 14) If additional assistance is required:

Tel: (613) 226-5772

Fax: (613) 226-2802

In Word

Mar 99

(last 2 pg separate)

not in AVO-8C file