



AVTECH ELECTROSYSTEMS LTD.

NANOSECOND WAVEFORM ELECTRONICS
SINCE 1975

□ P.O. BOX 265
OGDENSBURG, NY
U.S.A. 13669-0265
TEL: (315) 472-5270
FAX: (613) 226-2802

TEL: 1-800-265-6681
FAX: 1-800-561-1970
U.S.A. & CANADA

✠ BOX 5120 STN. F
OTTAWA, ONTARIO
CANADA K2C 3H4
TEL: (613) 226-5772
FAX: (613) 226-2802

INSTRUCTIONS

MODEL AVO-9B-C-EA-XXA PULSE GENERATOR
MODEL AVX-S1-MI-XXA BIAS INSERTION UNIT

S.N.:

WARRANTY

Avtech Electrosystems Ltd. warrants products of its manufacture to be free from defects in material and workmanship under conditions of normal use. If, within one year after delivery to the original owner, and after prepaid return by the original owner, this Avtech product is found to be defective, Avtech shall at its option repair or replace said defective item. This warranty does not apply to units which have been disassembled, modified or subjected to conditions exceeding the applicable specifications or ratings. This warranty is the extent of the obligation or liability assumed by Avtech with respect to this product and no other warranty or guarantee is either expressed or implied.

Fig. 1

PULSE GENERATOR TEST ARRANGEMENT

(AVX-S1 MODULE REMOVED)

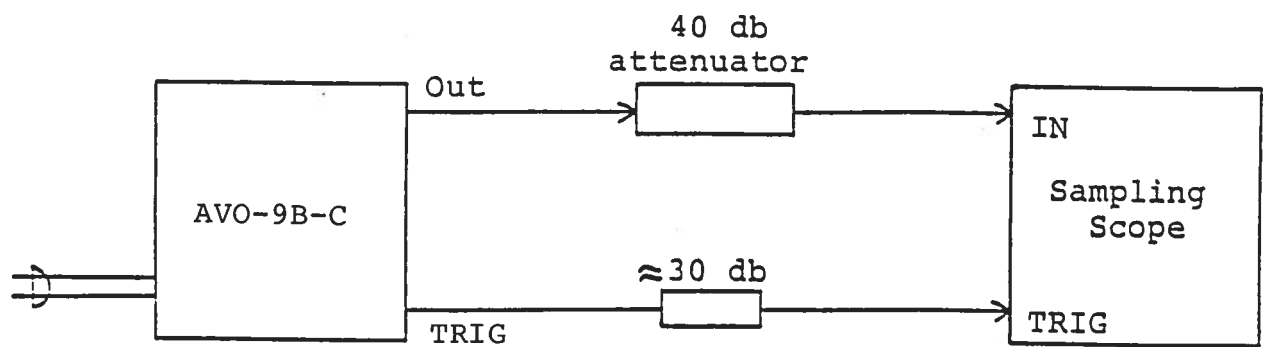

110V/220V
50-60 Hz

Notes:

- 1) The bandwidth capability of components and instruments used to display the pulse generator output signal (attenuators, cables, connectors, etc.) should exceed ten gigahertz.
- 2) The use of 40 db attenuator at the sampling scope vertical input channel will insure a peak input signal to the sampling scope of less than one volt.
- 3) The sync output channel provides TTL level signals. To avoid overdriving the TRIG input channel of some sampling scopes, a 30 db attenuator should be placed at the input to the sampling scope trigger channel.
- 4) To obtain a stable output display the PRF control on the front panel should be set mid-range while the PRF range switch may be in either range. The front panel TRIG toggle switch should be in the INT position. The front panel DELAY controls and the scope triggering controls are then adjusted to obtain a stable output. The scope may then be used to set the desired PRF by rotating the PRF control and by means of the PRF range switch.
- 5) The output pulse width is controlled by means of the front panel one turn PW control. The control should initially be set maximum clockwise and the pulse width adjusted using an oscilloscope.
- 6) The output pulse amplitude is controlled by means of the front panel one turn AMP control. The pulse width may change by several nanoseconds as the output amplitude is reduced from maximum to minimum. Therefore it is convenient to first set the desired amplitude and then set the desired pulse width. Rotation of the FW pot causes the position of the falling edge of the pulse to change.
- 7) Some properties of the output pulse may change as a function of the amplitude pot setting. For some demanding applications, it may be desirable to use a combination of external attenuators and the amplitude pot to achieve the desired output amplitude.
- 8) An external clock may be used to control the output PRF of the AVO unit by setting the front panel TRIG toggle switch in the EXT position and applying a 0.2 usec (approx) TTL level pulse to the TRIG BNC connector input. For operation in this mode, the scope time base must also be triggered by the external clock rather than from the SYNC output.

- 9) To voltage control the output pulse width, set the rear panel switch in the EXT position and apply 0 to +10V to connector A ($R_{IN} \geq 10K$). (EW option).
- 10) To voltage control the output amplitude, set the rear panel switch in the EXT position and apply 0 to +10V to connector B ($R_{IN} \geq 10K$). (EA option).
- 11) The unit can be converted from 110 to 220V 50-60 Hz operation by adjusting the voltage selector card in the rear panel fused voltage selector-cable connector assembly.
- 12) For additional assistance:
Tel: (613) 226-5772
Fax: (613) 226-2802

Fig. 2

PULSE GENERATOR TEST ARRANGEMENT

(AVX-S1 MODULE CONNECTED)

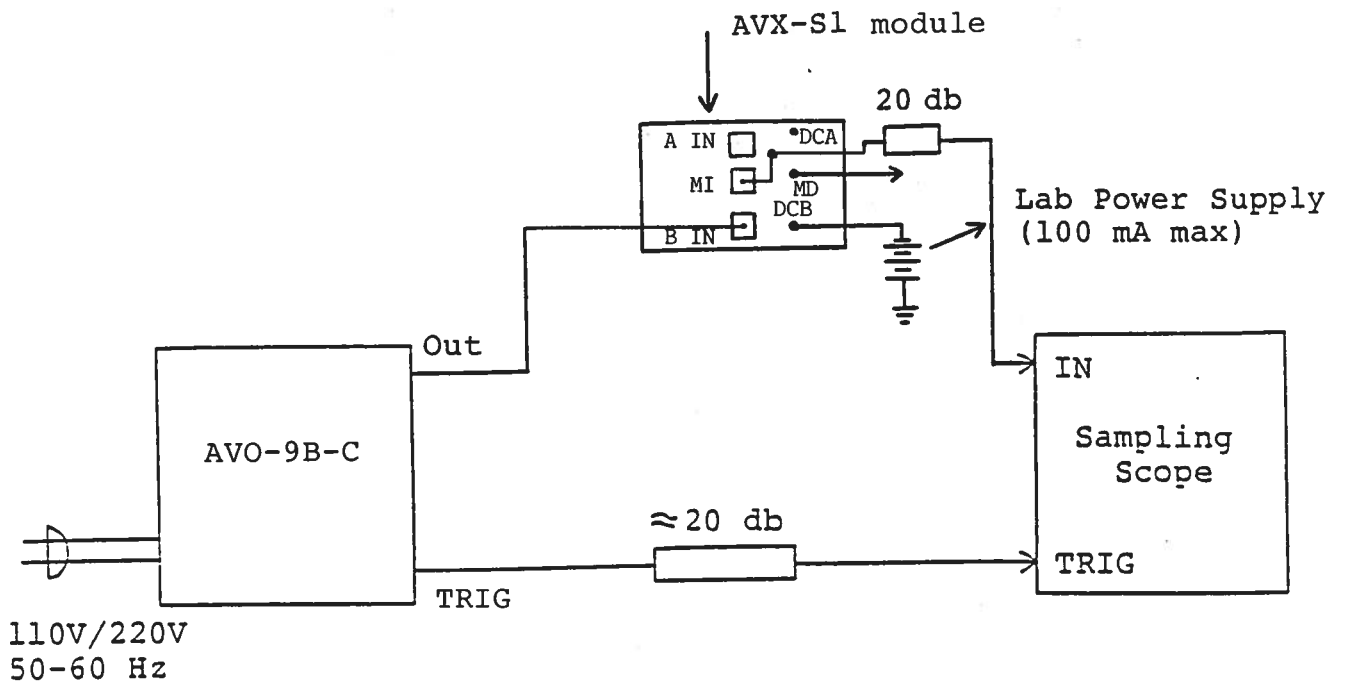

- 1) A general description of the AVX-S1 module is given in the enclosed data sheet.
- 2) The AVX-S1 module should be connected to the AVO-9B-C mainframe via the supplied 24" RG174 cable. The diode current may be monitored by connecting the MI output port to the sampling scope via a 20 db attenuator (MI option units only). The output amplitude (V_{MI} , volts) and diode current (I_D , Amp) are related as follows:

$$I_D = 0.2 V_{MI}$$

- 3) The laser diode plugs directly into the socket on the side of the AVX-S1 module.

CAUTION: A four PIN package can be inserted improperly so it is necessary to check the PIN matings using the drawings on the following page.

- 4) A forward DC bias may be applied to the laser diode by connecting a DC potential of 0 to +5 volts to the DC solder terminal. The application of a small forward bias often yields a more ideal diode current waveform (as observed on the MI port). Note that the DC port must be shorted to ground if a bias is not applied.
- 5) The input pulse and the DC bias should be switched to the A or B inputs as required to operate the A or B laser diode.

MR-51

(SN 6506)

JULY 9:

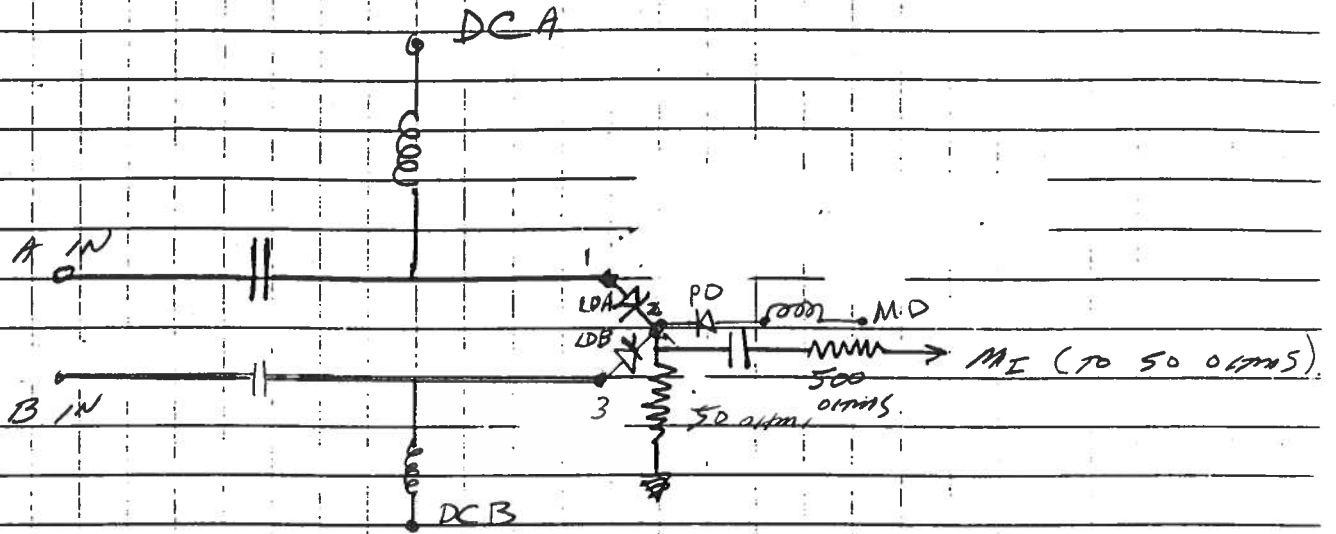

FUNCTIONAL EQUIV. C.T.

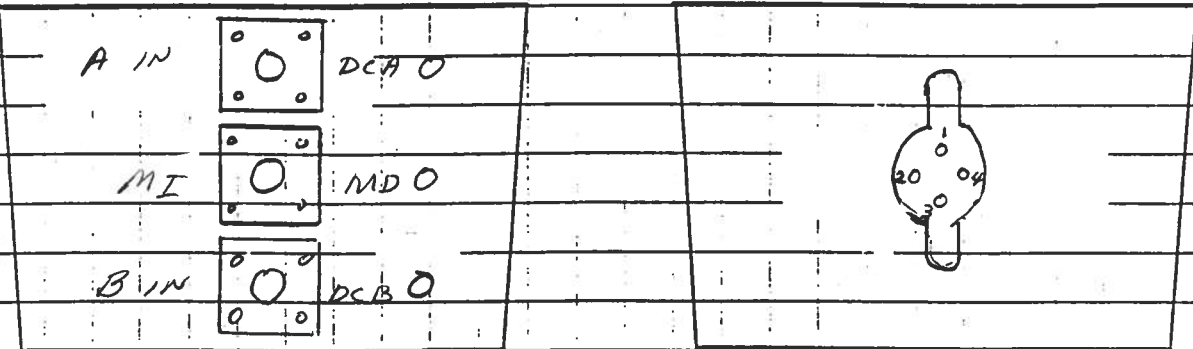

PACKAGE

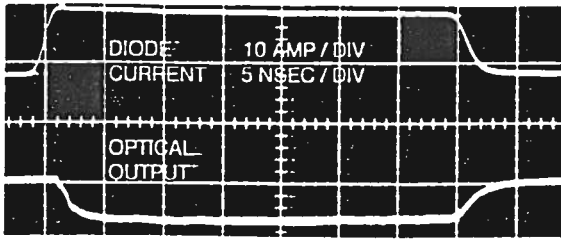

The AVX-S series of bias insertion units is designed for applying pulse or RF CW signals and DC bias to laser diodes which insert into a high quality socket included on the mount. The bias insertion module includes the necessary networks to match the laser diode to the pulse or RF source as well as networks for applying DC bias to the diode. Optional outputs allow for monitoring of the laser diode current, voltage and a photo detector diode output. Readily available socket configurations (TO-18, TO-5, TO-3, OP-3) are shown on the following page. Note that the laser diodes are not supplied with the AVX-S series.

The AVX-S series includes 3 basic models namely the AVX-S1, AVX-S2 and the AVX-S3. The basic functional equivalent circuit for the three models are shown below. Model AVX-S1 is specifically designed for ultra high-speed, low current applications (rise times as low as 200 psec, bandwidths to 1 GHz, $I < 1.0$ ampere). Model AVX-S1 is employed in the AVO-9-C series of diode drivers. Model AVX-S2 is intended for application with rise times greater than 2 nsec and currents above 1 ampere. Model AVX-S3 is specifically designed for use with the AVO-2 and AVO-5 series pulse generators (which provide currents in the range of 5 to 50 amperes).

The input series blocking capacitor in Models AVX-S1 and AVX-S2 presents a low impedance to RF CW signals and to baseband pulses while the shunt indicator presents a high impedance to RF (or pulse) signals but an extremely low impedance to the DC bias. The resistor in series with the laser diode is selected to insure that the impedance at the IN port is 50 ohms. Normally a laser diode resistance of 3 ohms is assumed.

The optional diode current monitor (M_I) provides an output waveform (to 50 ohms) which is an attenuated replica of the laser diode current. The output amplitude (V_{MI} , volts) and diode current (I_D , Amps) are related as follows:

$$\text{-S1: } I_D = 0.2V_{MI} \quad \text{-S2: } I_D = V_{MI}$$

The optional diode voltage monitor (MV) provides an output waveform that may be related to the voltage across the laser diode (V_D , volts) as follows:

$$\text{-S1: } V_D = 10(V_{MV} - V_{MI}) \quad \text{-S2: } V_D = 10V_{MV}$$

- Socket mounting of laser diodes
- Peak currents from 100 mA to 48 Amps
- Pulse widths from 0.4 to 200 nsec
- Rise times from 0.2 to 2.0 nsec
- Pulse or CW RF
- Diode current and voltage monitor options

Model AVX-S3 is available in four different versions (AVX-S3A, AVX-S3B, AVX-S3C and AVX-S3D) all of which include a matching transformer which effectively boosts the laser diode current beyond that provided by the pulse source.

Model AVX-S3A is designed to match 50 ohm pulse generators such as Model AVO-2-C to 12 ohm loads with peak currents of 5 amperes. Consequently, the resistor R_S in the equivalent circuit for this model is 10 ohm. This resistor is accessible in all AVX-S3 models and may be changed by the user (by desoldering). The series resistance of the laser diode and the resistor R_S must equal the pulse generator source impedance divided by N^2 . Consequently, if the series resistance of the laser diode is relatively high, it then may be necessary to reduce the value of R_S . Model AVX-S3B is designed to match 50 ohm pulse generators such as Model AVO-5-C to 3 ohms and will provide peak diode currents up to 28 amperes. Model AVX-S3C is designed to match Models AVO-2W-C and AVO-2-C (25 ohm source impedance) to load resistance of about 5 ohms and will provide peak diode currents as high as 10 amperes. Model AVX-S3D is designed for use with Model AVO-5B-C and will provide up to 48 amperes of diode current.

Two optional SMA output connectors provide attenuated coincident replicas of the diode current (-MI option) and diode voltage (-MV option) as per the following relationships (Amps, Volts):

$$I_D = \frac{10 V_{MI}}{R_S} \quad V_D = 10(V_{MV} - V_{MI})$$

All AVX-S3 units include two foot long input cables with SMA male connectors.

When ordering members of the AVX-S family, the customer must specify the basic model number (eg. AVX-S1) and the following additional information.

- Diode package type (eg. TO-18) and the required pin connections (eg. anode, cathode, ground etc). See the following page for readily available package mounting. Contact Avtech for special or different packages.
- Desired options (eg. -MI, -MV, -MD).

Contact Avtech for your special requirements.

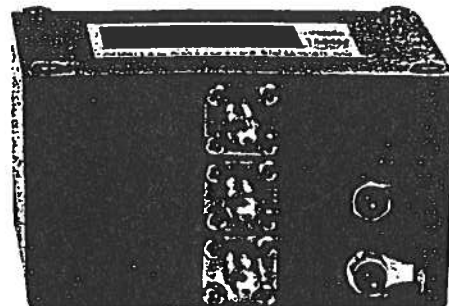
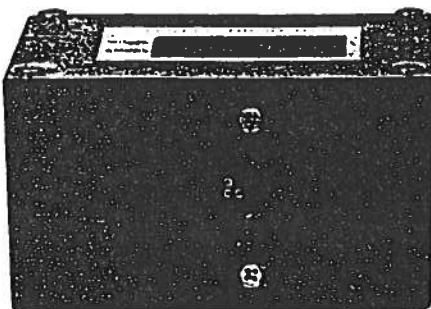

SPECIFICATIONS

AVX-S SERIES

Model:	AVX-S1	AVX-S2	AVX-S3A	AVX-S3B	AVX-S3C	AVX-S3D
Peak diode current:	400 mA	2 Amps	5 Amps	28 Amps	10 Amps	48 Amps
Max. input amplitude:	20 volts	100 volts	150 volts	350 volts	150 volts	150 volts
Pulse width (nsec):	0.4 - 200	1 - 1000	2 - 100	2 - 100	2 - 100	5 - 500
Rise time (nsec):	0.2	0.5	0.5	1.0	0.5	2.0
Pulse PRF range:	DC - 0.5 GHz	DC - 100 MHz	DC - 10 MHz	DC-10 MHz	DC - 10 MHz	DC - 1 MHz
CW frequency range:	10 MHz - 1.0 GHz	1 - 200 MHz	-	-	-	-
Max. bias current:	100 mA	100 mA	100 mA	100 mA	100 mA	100 mA
Max. bias voltage:	50 volts	50 volts	50 volts	50 volts	50 volts	50 volts
Input impedance:	50 ohms	50 ohms	50 ohms	50 ohms	25 ohms	12 ohms
N:	-	-	2	4	2	4
R _s (ohms):	-	-	10	3	5	0.7
IN connector:	SMA					
Monitor connector:	SMA					
Bias connector:	Solder pin					
Size (in):	1.6 x 2.6 x 3.0					
Material:	Cast aluminum, blue enamel					
Mounting:	Any					

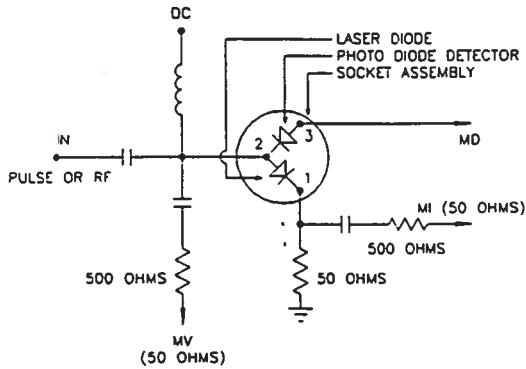

AVX-S1 FUNCTIONAL EQUIVALENT CIRCUIT

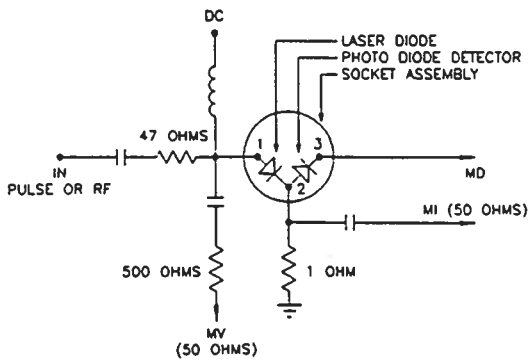

AVX-S2 FUNCTIONAL EQUIVALENT CIRCUIT

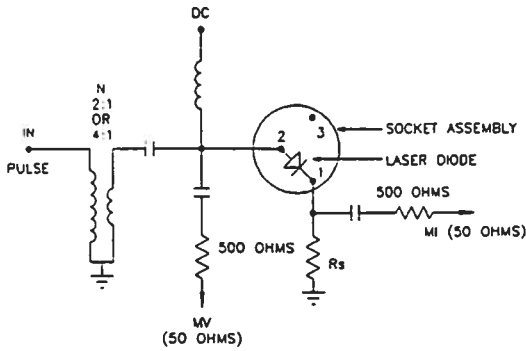

AVX-S3 FUNCTIONAL EQUIVALENT CIRCUIT

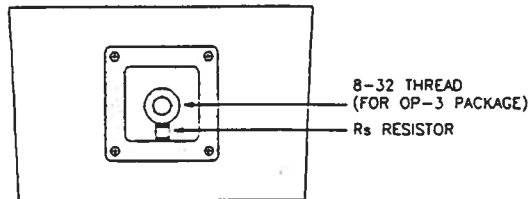

AVX-S3 INPUT ASSEMBLY (FOR OP-3 PACKAGE)

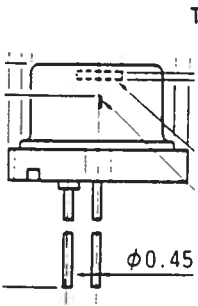

TO-18

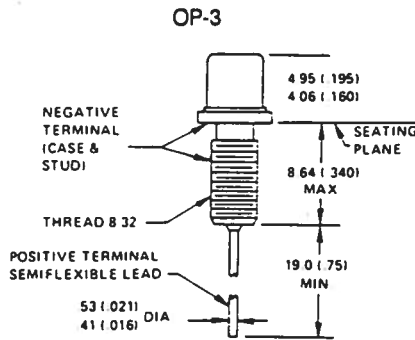

OP-3

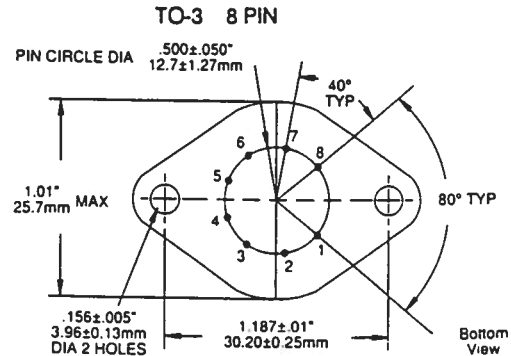

TO-3 8 PIN

TYPICAL PACKAGES

Fig. 3

FRONT PANEL CONTROLS

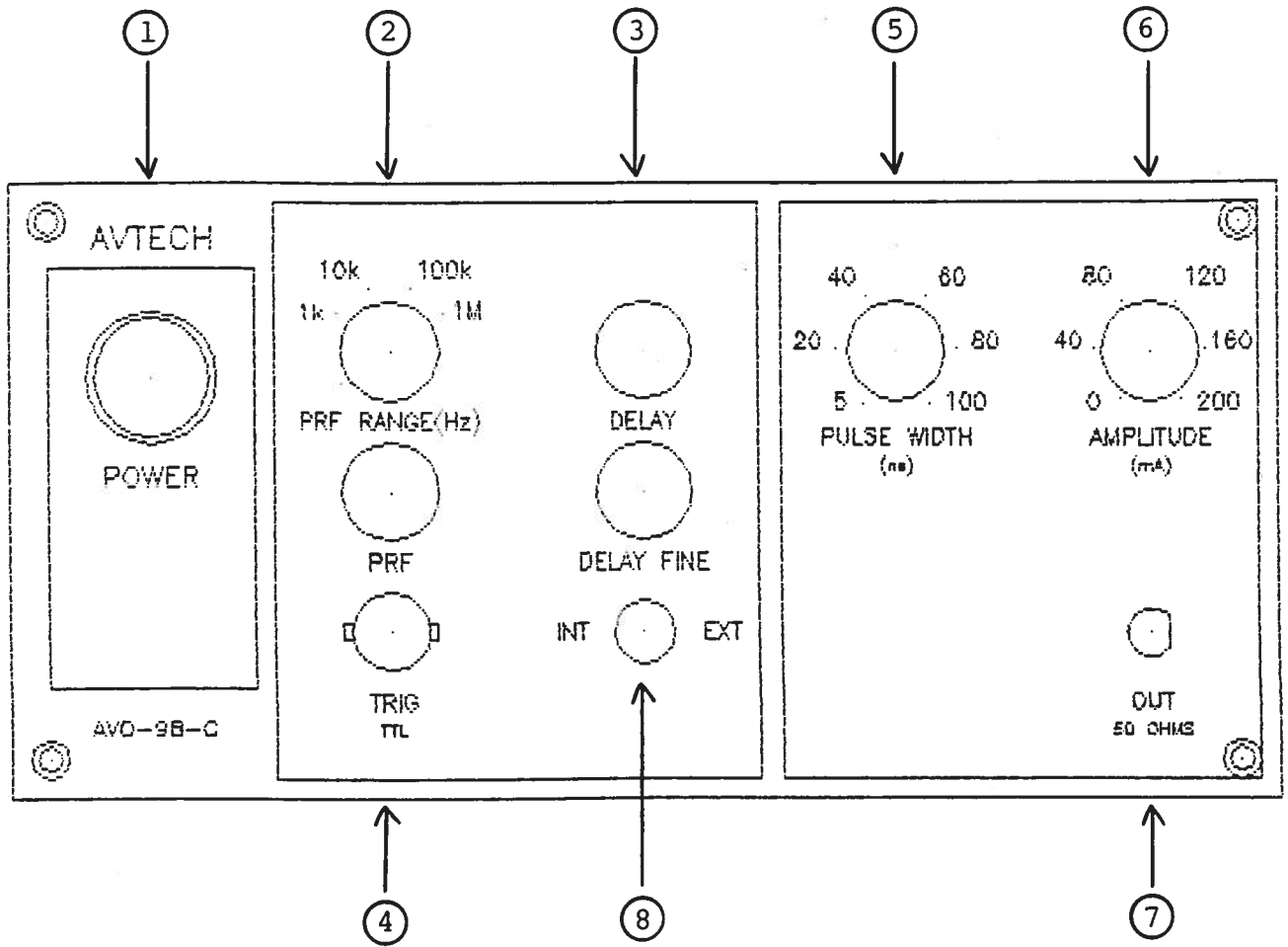

- (1) ON-OFF_Switch. Applies basic prime power to all stages.
- (2) PRF_Control. The PRF RANGE and PRF controls determine output PRF as follows:

	PRF MIN	PRF MAX
Range 1	100 Hz	1 kHz
Range 2	1 kHz	10 kHz
Range 3	10 kHz	100 kHz
Range 4	100 kHz	1 MHz

- (3) DELAY Controls. Controls the relative delay between the reference output pulse provided at the TRIG output (4) and the main output (7). This delay is variable over the range of 0 to at least 500 ns.
- (4) TRIG_Output. This output precedes the main output and is used to trigger the sampling scope time base. The output is a TTL level 100 ns (approx) pulse capable of driving a fifty ohm load.
- (5) PW_Control. A one turn control which varies the output pulse width from 5 to 100 ns.
- (6) AMP_Control. A one turn control which varies the output pulse amplitude.
- (7) OUT. SMA connector provides output to 50 ohm load.
- (8) EXT-INT_Control. With this toggle switch in the INT position, the PRF of the AVO unit is controlled via an internal clock which in turn is controlled by the PRF controls. With the toggle switch in the EXT position, the AVO unit requires a 0.2 us TTL level pulse applied at the TRIG input in order to trigger the output stages. In addition, in this mode, the scope time base must be triggered by the external trigger source.

Fig. 4

BACK PANEL CONTROLS

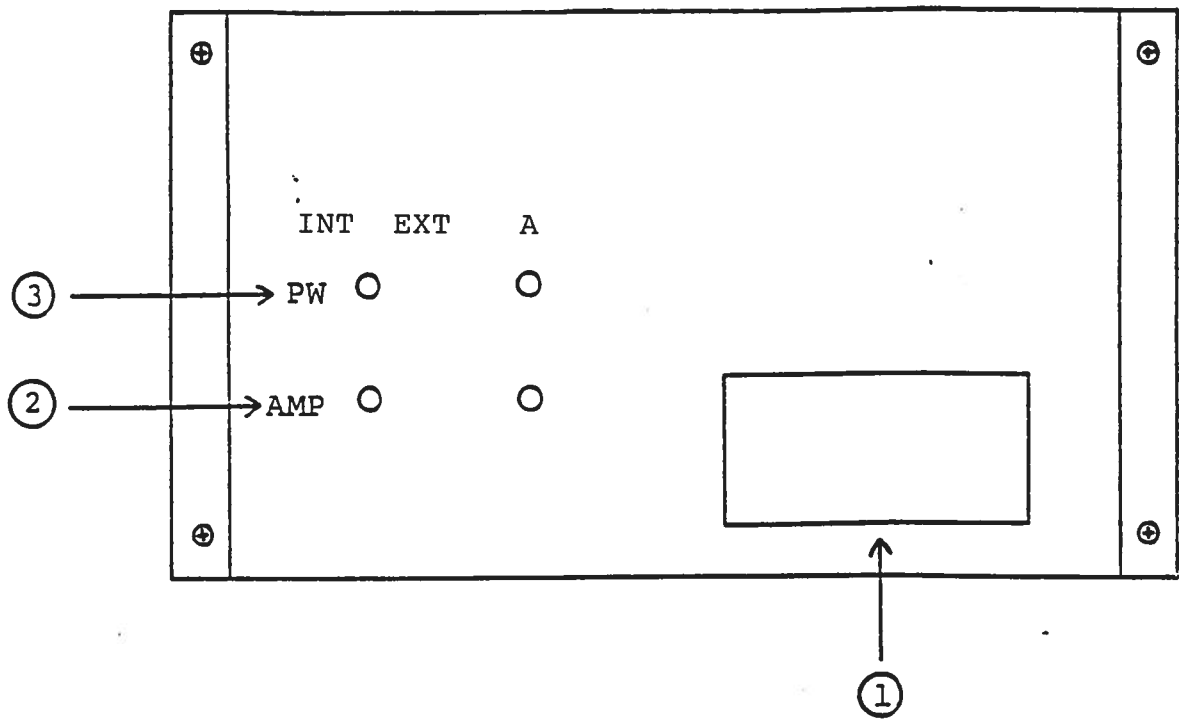

- (1) FUSED CONNECTOR, VOLTAGE SELECTOR. The detachable power cord is connected at this point. In addition, the removable cord is adjusted to select the desired input operating voltage. The unit also contains the main power fuse (0.25 A SB).
- (2) EA. To voltage control the output amplitude, set the switch in the EXT position and apply 0 to +10 volts between terminal A and ground ($R_{IN} \geq 10K$). (option).
- (3) EW. To voltage control the output pulse width, set the switch in the EXT position and apply 0 to +10 volts between terminal A and ground ($R_{IN} \geq 10K$). (option).

Fig. 4

SYSTEM BLOCK DIAGRAM

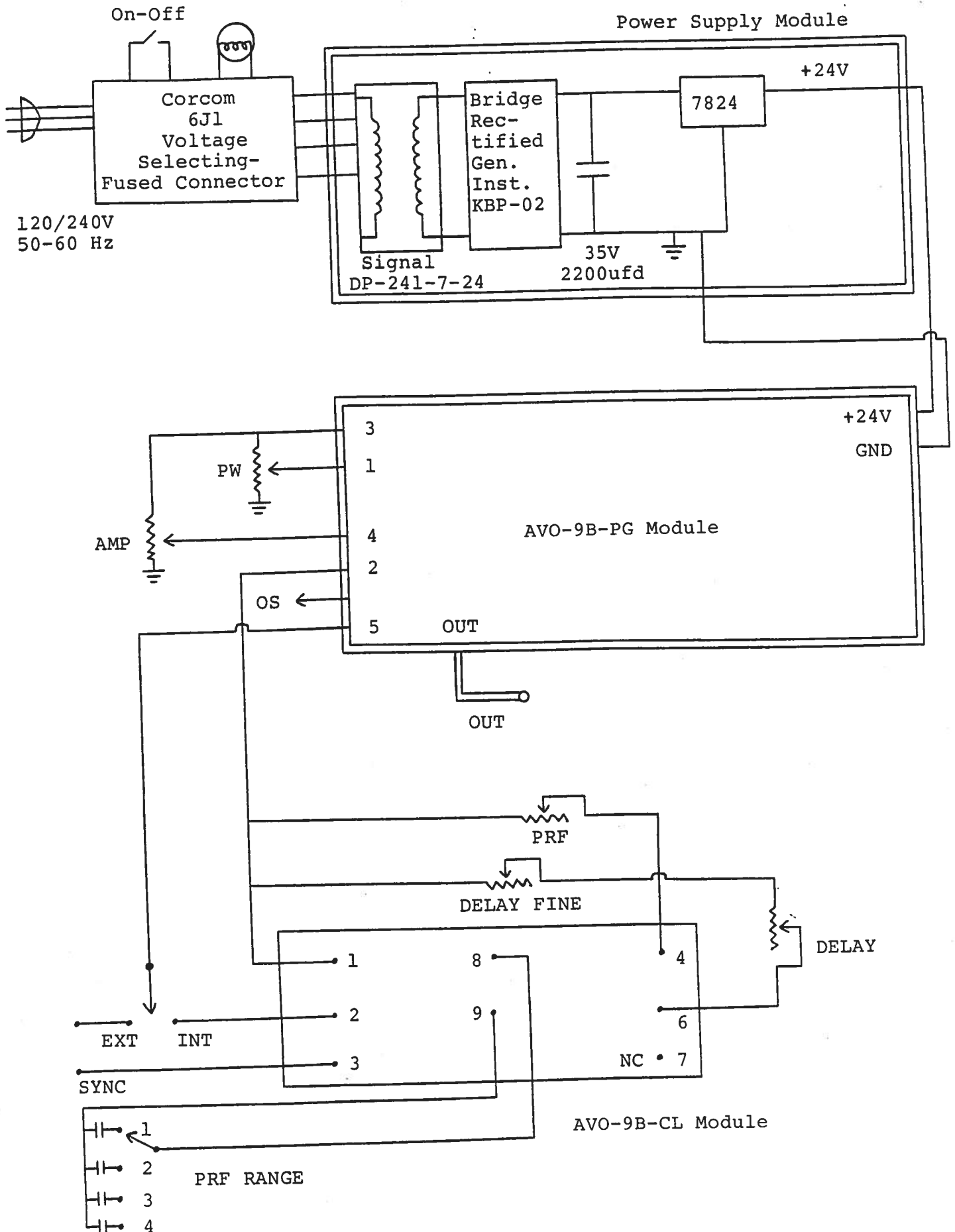

SYSTEM DESCRIPTION AND REPAIR PROCEDURE

The AVO-9B-C consists of a pulse generator module (AVO-9B-PG), a clock module (AVO-9B-CL) and a power supply board which supplies +24 volts (600 mA max) to the pulse generator module. In the event that the unit malfunctions, remove the instrument cover by removing the four Phillips screws on the back panel of the unit. The top cover may then be slid off. Measure the voltage at the +24V pin of the PG module. If this voltage is substantially less than +24 volts, unsolder the line connecting the power supply and PG modules and connect 100 ohm 10 W load to the PS output. The voltage across this load should be about +24 V DC. If this voltage is substantially less than 24 volts the PS module is defective and should be repaired or replaced. If the voltage across the resistor is near 24 volts, then the PG module should be replaced or repaired. The sealed PG module must be returned to Avtech for repair (or replacement). The clock module provides a 0.1 usec TTL level trigger pulse at pin 2 to trigger the PG module and a 0.1 usec TTL level sync pulse at pin 3 to trigger the sampling scope display device. The output at pin 3 precedes the output at pin 2 by almost 0 to 100 nsec depending on the DELAY control setting. The clock module is powered by +5.8 V supplied by the PG module (from pin 2 to pin 1). With the INT-EXT switch in the EXT position, the clock module is disconnected from the PG module. The clock module is functioning properly if:

- a) 0.1 usec TTL level outputs are observed at pins 2 and 3.
- b) The PRF of the outputs can be varied over the range of 1 KHz to 1 MHz using the PRF and PRF RANGE controls.
- c) The relative delay between the pin 2 and 3 outputs can be varied by at least 500 nsec by the DELAY controls.

The sealed clock module must be returned to Avtech for repair or replacement if the above conditions are not observed.

July 20/93

-EW

-EA