

AVTECH ELECTROSYSTEMS LTD.

NANOSECOND WAVEFORM ELECTRONICS
ENGINEERING - MANUFACTURING

□ P.O. BOX 265
OGDENSBURG
NEW YORK
13669
(315) 472-5270

BOX 5120, STN. "F"
OTTAWA, ONTARIO
CANADA K2C 3H4
TEL: (613) 226-5772
FAX: (613) 226-2802

INSTRUCTIONS

MODEL AVQ-9E-C-P-MI-POL1 PULSE GENERATOR

S.N. :

WARRANTY

Avtech Electrosystems Ltd. warrants products of its manufacture to be free from defects in material and workmanship under conditions of normal use. If, within one year after delivery to the original owner, and after prepaid return by the original owner, this Avtech product is found to be defective, Avtech shall at its option repair or replace said defective item. This warranty does not apply to units which have been disassembled, modified or subjected to conditions exceeding the applicable specifications or ratings. This warranty is the extent of the obligation or liability assumed by Avtech with respect to this product and no other warranty or guarantee is either expressed or implied.

Fig. 1

PULSE GENERATOR TEST ARRANGEMENT

(AVX-S3 MODULE DISCONNECTED)

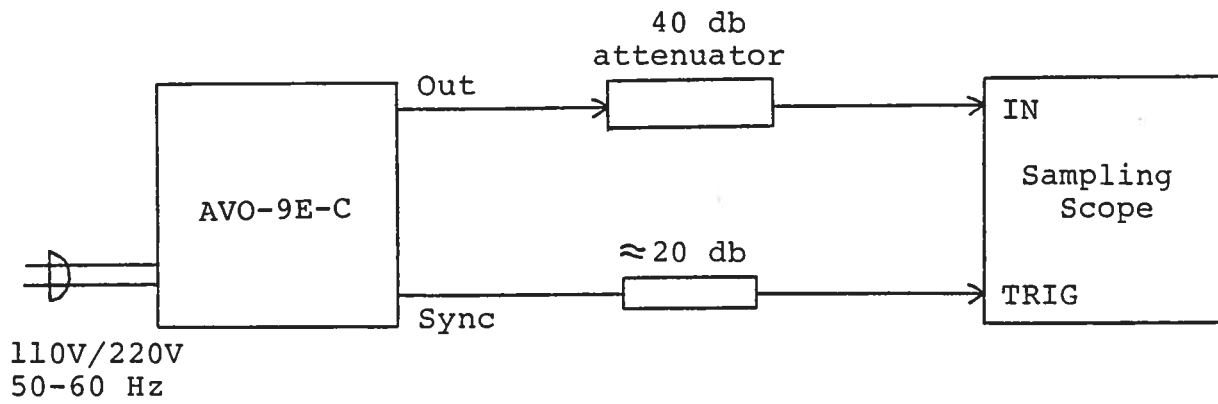

Notes:

- 1) The bandwidth capability of components and instruments used to display the pulse generator output signal (attenuators, cables, connectors, etc.) should exceed one gigahertz.
- 2) The use of 40 db attenuator at the sampling scope vertical input channel will insure a peak input signal to the sampling scope of less than one volt.
- 3) The sync output channel provides a +0.5 V pulse. To avoid overdriving the TRIG input channel of some sampling scopes, a 20 db attenuator should be placed at the input to the sampling scope trigger channel.
- 4) To obtain a stable output display the PRF and PRF FINE controls on the front panel should be set mid-range while the PRF range switch may be in either range. The front panel TRIG toggle switch should be in the INT position. The front panel DELAY control and the scope triggering controls are then adjusted to obtain a stable output. It is recommended that the DELAY control first be set max counter clockwise and then turned clockwise until a stable display is obtained. The scope may then be used to set the desired PRF by rotating the PRF and PRF FINE controls and by means of the PRF range switch.
- 5) The output pulse width is controlled by means of the front panel one turn PW control. The control should initially be set maximum counter clockwise and the pulse width adjusted using an oscilloscope.
- 6) To voltage control the output pulse width, remove the jumper wire between banana plugs A and B on the back panel and apply 0 to +10V to connector B ($R_{IN} \geq 10K$). (EW option).
- 7) The output pulse amplitude is controlled by means of the front panel one turn AMP control.
- 8) To voltage control the output amplitude, remove the jumper wire between banana plugs A and B on the back panel and apply 0 to +10V to connector B ($R_{IN} \geq 10K$). (EA option).
- 9) An external clock may be used to control the output PRF of the AVO-9E unit by setting the front panel TRIG toggle switch in the EXT position and applying a 50 nsec, or under, TTL level pulse to the TRIG BNC connector input. For operation in this mode, the scope time base must also be triggered by the external clock rather than from the SYNC output.

- 10) WARNING: Model AVO-9E-C may fail if triggered at a PRF greater than 10.0 MHz or at a duty cycle exceeding 20%.
- 11) AVO-9E units with a serial number higher than 5600 are protected by an automatic overload protective circuit which controls the front panel overload light. If the unit is overloaded (by operating at an exceedingly high duty cycle or by operating into a short circuit), the protective circuit will turn the output of the instrument OFF and turn the indicator light ON. The light will stay ON (i.e. output OFF) for about 5 seconds after which the instrument will attempt to turn ON (i.e. light OFF) for about 1 second. If the overload condition persists, the instrument will turn OFF again (i.e. light ON) for another 5 seconds. If the overload condition has been removed, the instrument will turn on and resume normal operation. Overload conditions may be removed by:
 - 1) Reducing PRF (i.e. switch to a lower range)
 - 2) Reducing pulse width (i.e. switch to a lower range)
 - 3) Removing output load short circuit (if any)
- 12) Dual Polarity Option. To invert the output of the AVO-9E unit, connect the IN PORT of an AVX-3 unit to the OUT port of the AVO-9E mainframe. An inverted pulse is then obtained at the OUT port of the AVX-3 unit.
- 13) The AVO-9E-C unit can be converted from 110 to 220V 50-60 Hz operation by adjusting the voltage selector card in the rear panel fused voltage selector-cable connector assembly.

Fig. 2

PULSE GENERATOR TEST ARRANGEMENT

(AVX-S3 MODULE CONNECTED)

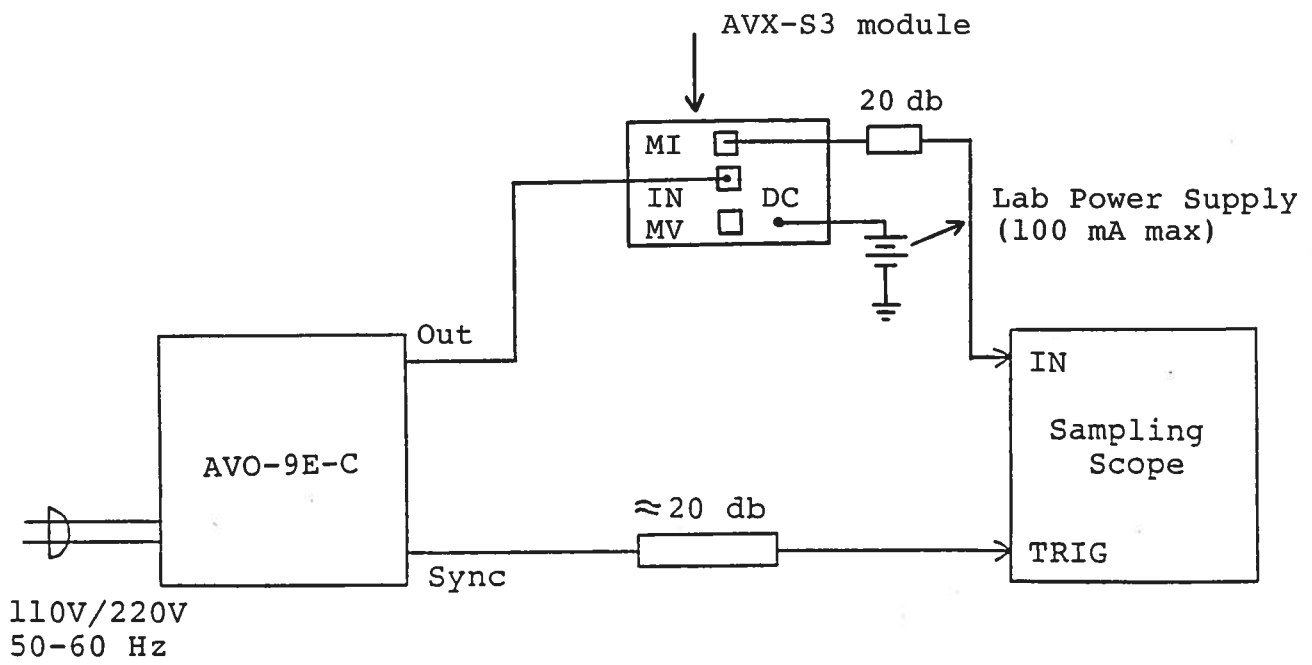

MX-53-ME-POL1

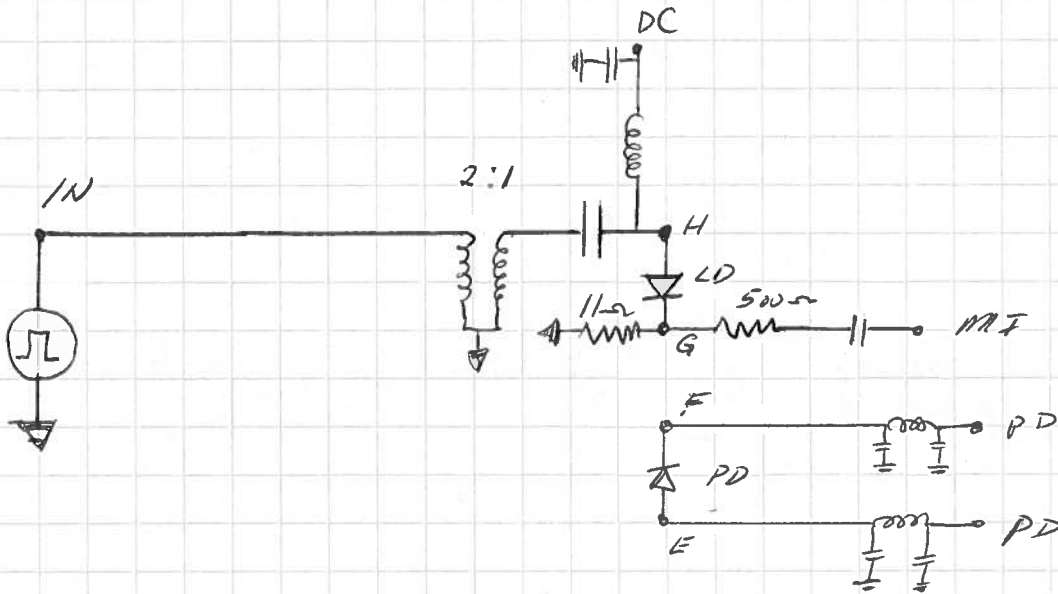

FUNCTIONAL EQUIVALENT CIRCUIT

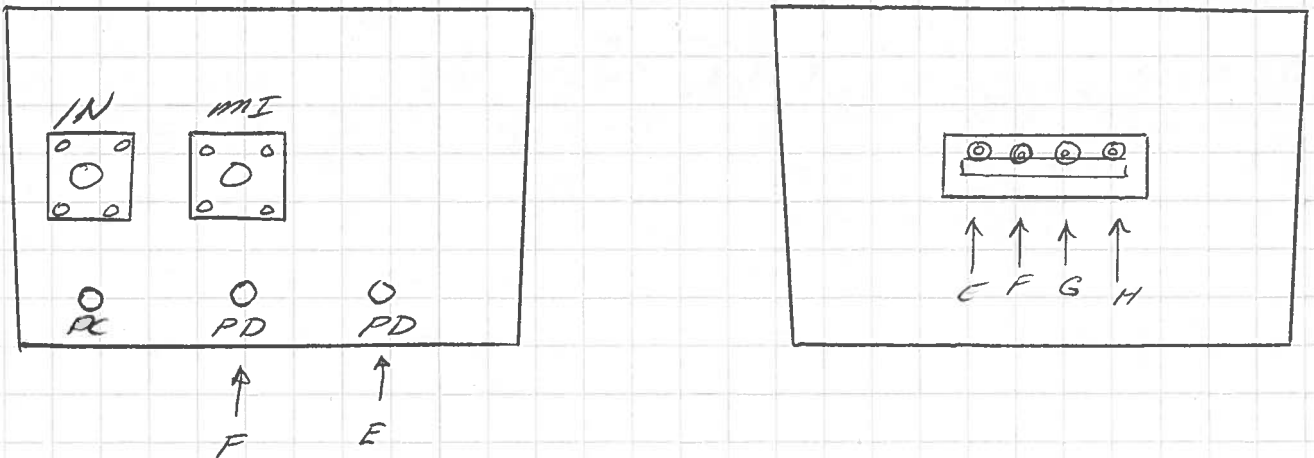
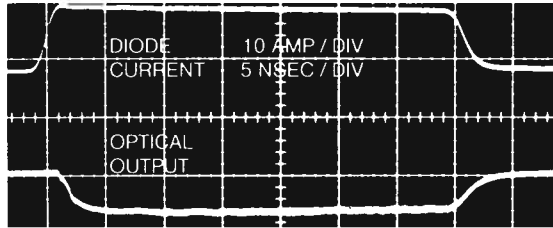

PHOTO AID



The AVX-S series of bias insertion units is designed for applying pulse or RF CW signals and DC bias to laser diodes which insert into a high quality socket included on the mount. The bias insertion module includes the necessary networks to match the laser diode to the pulse or RF source as well as networks for applying DC bias to the diode. Optional outputs allow for monitoring of the laser diode current, voltage and a photo detector diode output. Readily available socket configurations (TO-18, TO-5, TO-3, OP-3) are shown on the following page. Note that the laser diodes are not supplied with the AVX-S series.

The AVX-S series includes 3 basic models namely the AVX-S1, AVX-S2 and the AVX-S3. The basic functional equivalent circuit for the three models are shown below. Model AVX-S1 is specifically designed for ultra high-speed, low current applications (rise times as low as 200 psec, bandwidths to 1 GHz, $I < 1.0$ ampere). Model AVX-S1 is employed in the AVO-9-C series of diode drivers. Model AVX-S2 is intended for application with rise times greater than 2 nsec and currents above 1 ampere. Model AVX-S3 is specifically designed for use with the AVO-2 and AVO-5 series pulse generators (which provide currents in the range of 5 to 50 amperes).

The input series blocking capacitor in Models AVX-S1 and AVX-S2 presents a low impedance to RF CW signals and to baseband pulses while the shunt inductor presents a high impedance to RF (or pulse) signals but an extremely low impedance to the DC bias. The resistor in series with the laser diode is selected to insure that the impedance at the IN port is 50 ohms. Normally a laser diode resistance of 3 ohms is assumed.

The optional diode current monitor (M_I) provides an output waveform (to 50 ohms) which is an attenuated replica of the laser diode current. The output amplitude (V_{MI} , volts) and diode current (I_D , Amps) are related as follows:

$$\text{-S1: } I_D = 0.2V_{MI} \quad \text{-S2: } I_D = V_{MI}$$

The optional diode voltage monitor (MV) provides an output waveform that may be related to the voltage across the laser diode (V_D , volts) as follows:

$$\text{-S1: } V_D = 10(V_{MV} - V_{MI}) \quad \text{-S2: } V_D = 10V_{MV}$$

- Socket mounting of laser diodes
- Peak currents from 100 mA to 48 Amps
- Pulse widths from 0.4 to 200 nsec
- Rise times from 0.2 to 2.0 nsec
- Pulse or CW RF
- Diode current and voltage monitor options

Model AVX-S3 is available in four different versions (AVX-S3A, AVX-S3B, AVX-S3C and AVX-S3D) all of which include a matching transformer which effectively boosts the laser diode current beyond that provided by the pulse source.

Model AVX-S3A is designed to match 50 ohm pulse generators such as Model AVO-2-C to 12 ohm loads with peak currents of 5 amperes. Consequently, the resistor R_S in the equivalent circuit for this model is 10 ohm. This resistor is accessible in all AVX-S3 models and may be changed by the user (by desoldering). The series resistance of the laser diode and the resistor R_S must equal the pulse generator source impedance divided by N^2 . Consequently, if the series resistance of the laser diode is relatively high, it then may be necessary to reduce the value of R_S . Model AVX-S3B is designed to match 50 ohm pulse generators such as Model AVO-5-C to 3 ohms and will provide peak diode currents up to 28 amperes. Model AVX-S3C is designed to match Models AVO-2W-C and AVO-2-C (25 ohm source impedance) to load resistance of about 5 ohms and will provide peak diode currents as high as 10 amperes. Model AVX-S3D is designed for use with Model AVO-5B-C and will provide up to 48 amperes of diode current.

Two optional SMA output connectors provide attenuated coincident replicas of the diode current (-MI option) and diode voltage (-MV option) as per the following relationships (Amps, Volts):

$$I_D = \frac{10 V_{MI}}{R_S} \quad V_D = 10(V_{MV} - V_{MI})$$

All AVX-S3 units include two foot long input cables with SMA male connectors.

When ordering members of the AVX-S family, the customer must specify the basic model number (eg. AVX-S1) and the following additional information.

- Diode package type (eg. TO-18) and the required pin connections (eg. anode, cathode, ground etc). See the following page for readily available package mounting. Contact Avtech for special or different packages.
- Desired options (eg. -MI, -MV, -MD).

Contact Avtech for your special requirements.

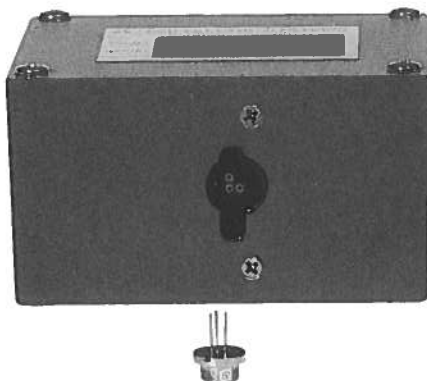

SPECIFICATIONS

AVX-S SERIES

Model:	AVX-S1	AVX-S2	AVX-S3A	AVX-S3B	AVX-S3C	AVX-S3D
Peak diode current:	400 mA	2 Amps	5 Amps	28 Amps	10 Amps	48 Amps
Max. input amplitude:	20 volts	100 volts	150 volts	350 volts	150 volts	150 volts
Pulse width (nsec):	0.4 - 200	1 - 1000	2 - 100	2 - 100	2 - 100	5 - 500
Rise time (nsec):	0.2	0.5	0.5	1.0	0.5	2.0
Pulse PRF range:	DC - 0.5 GHz	DC - 100 MHz	DC - 10 MHz	DC-10 MHz	DC - 10 MHz	DC - 1 MHz
CW frequency range:	10 MHz - 1.0 GHz	1 - 200 MHz	-	-	-	-
Max. bias current:	100 mA	100 mA	100 mA	100 mA	100 mA	100 mA
Max. bias voltage:	50 volts	50 volts	50 volts	50 volts	50 volts	50 volts
Input impedance:	50 ohms	50 ohms	50 ohms	50 ohms	25 ohms	12 ohms
N:	-	-	2	4	2	4
R _s (ohms):	-	-	10	3	5	0.7
IN connector:	SMA					
Monitor connector:	SMA					
Bias connector:	Solder pin					
Size (in):	1.6 x 2.6 x 3.0					
Material:	Cast aluminum, blue enamel					
Mounting:	Any					

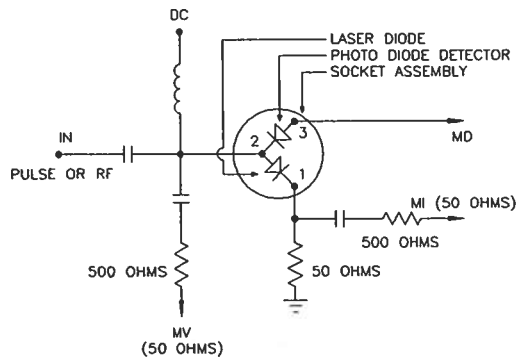

AVX-S1 FUNCTIONAL EQUIVALENT CIRCUIT

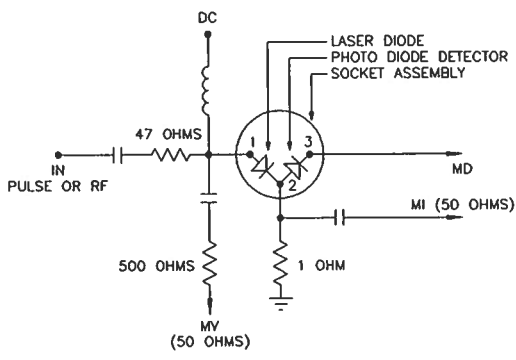

AVX-S2 FUNCTIONAL EQUIVALENT CIRCUIT

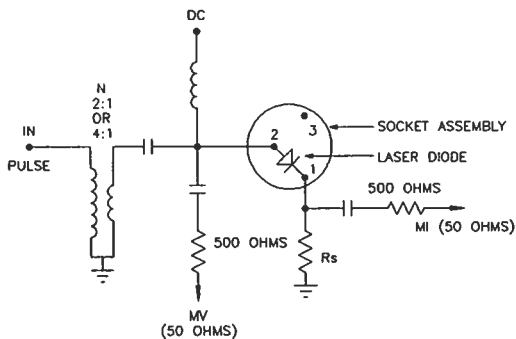

AVX-S3 FUNCTIONAL EQUIVALENT CIRCUIT

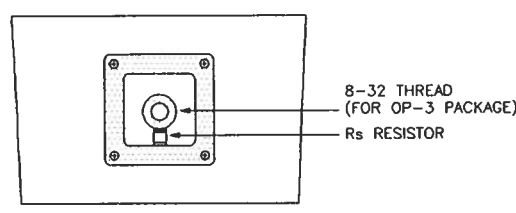

AVX-S3 INPUT ASSEMBLY (FOR OP-3 PACKAGE)

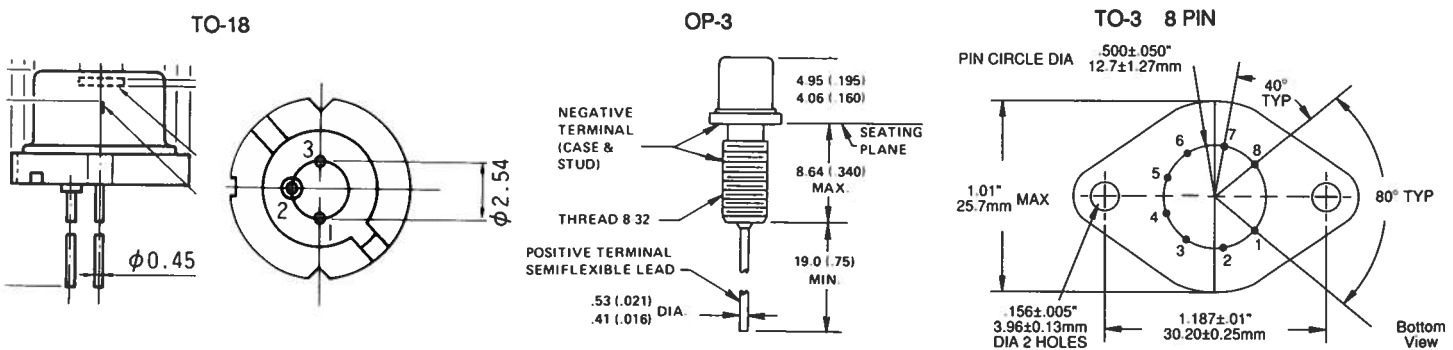

TYPICAL PACKAGES

- 1) The AVX-S3 module should be connected to the AVO-9E-C mainframe via the supplied 24" RG174 cable. The diode current may be monitored by connecting the MI output port to the sampling scope via a 20 db attenuator.
- 2) The laser diode butterfly package plugs directly into the socket on the side of the AVX-S3 module.
- 3) A forward DC bias may be applied to the laser diode by connecting a DC potential of 0 to +5 volts to the DC solder terminal. The application of a small forward bias often yields a more ideal diode current waveform (as observed on the MI port). Note that the DC port must be shorted to ground if a bias is not applied.
- 4) The diode current I_D (AMPS) and the M_x output voltage (VOLTS) are related as follows:

$$I_D = 0.91 M_x$$

- 5) A general description of the AVX-S3 module is given in the enclosed data sheet.

Fig. 3

FRONT PANEL CONTROLS

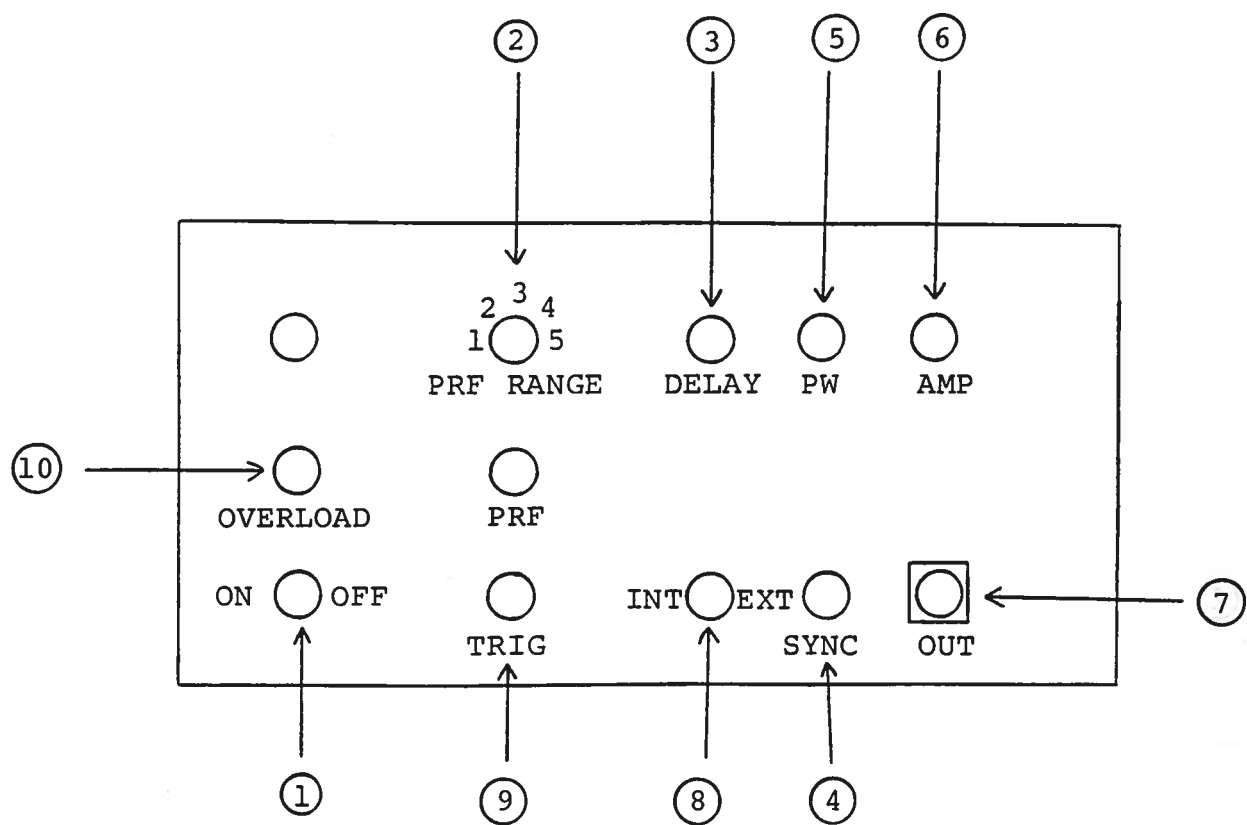

Fig. 4

BACK PANEL CONTROLS

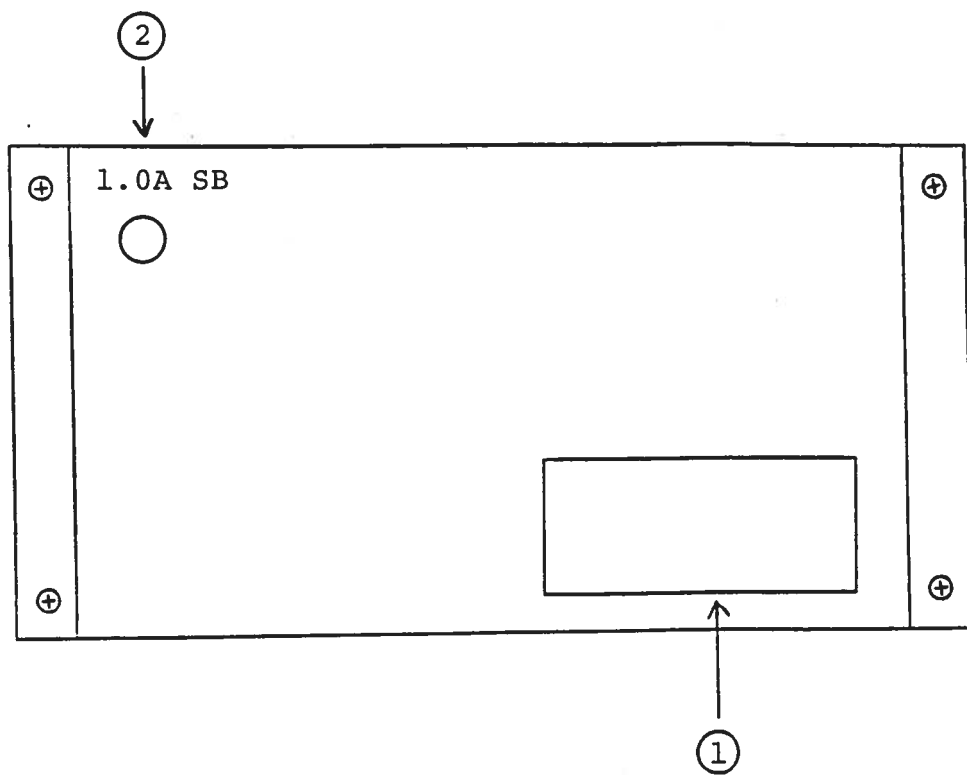
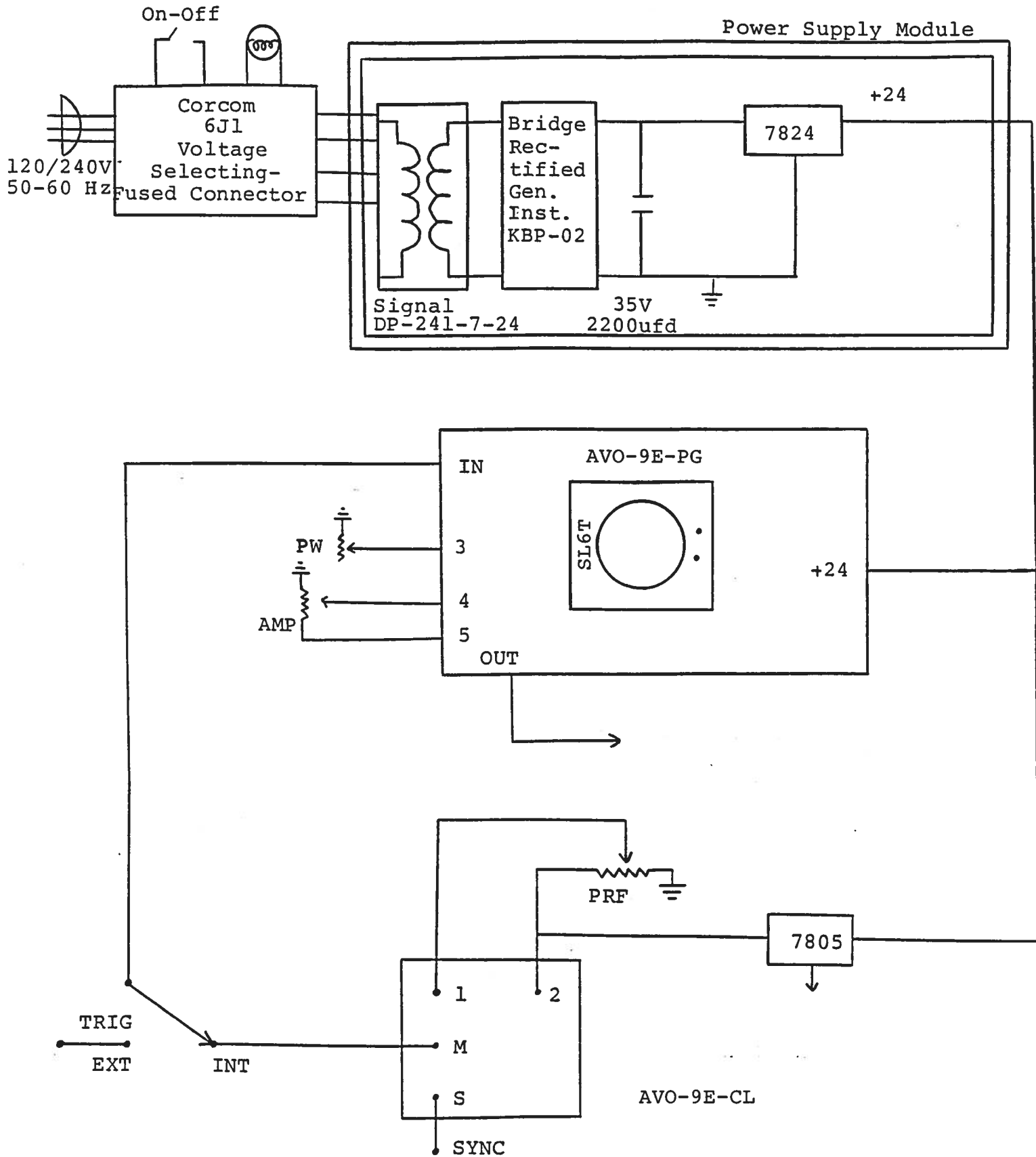

Fig. 4

SYSTEM BLOCK DIAGRAM



SYSTEM DESCRIPTION AND REPAIR PROCEDURE

The AV0-9E-C consists of the following basic modules:

- 1) AV0-9E-PG pulse generator module
- 2) AV0-9E-CL clock module
- 3) +24V power supply board

The modules are interconnected as shown in Fig. 4.

The clock module controls the output PRF and the relative delay between the main output and the SYNC outputs. The PG pulse generator modules generate the output pulse. In the event of an instrument malfunction, it is most likely that the rear panel 1.0 A SB fuse or some of the output switching elements (SL6T) may have failed due to an output short circuit condition or to a high duty cycle condition. The switching elements may be accessed by removing the cover plate on the bottom side of the chassis. NOTE: First turn off the prime power. CAUTION: Briefly ground the SL6T tabs to discharge the 36 volts power supply potential. The elements may be removed from their sockets by means of a needle nosed pliers after removing the four 2-56 Phillips screws which attach the small copper heat sink to the body of the chassis. The SL6T is a selected VMOS power transistor in a TO 220 package and may be checked on a curve tracer. If defective, replacement units should be ordered directly from Avtech. When replacing the SL6T switching elements, take care to insure that the short lead (of the three leads) is adjacent to the black dot on the chassis. The SL6T elements are electrically isolated from the small copper heat sink but are bonded to the heat sinks using WAKEFIELD TYPE 155 HEAT SINK ADHESIVE. If the switching elements are not defective, then the four Phillips screws on the back panel should be removed. The top cover may then be slid off and the operation of the clock and power supply modules checked. The clock module is functioning properly if:

- a) 20 nsec outputs are observed at pins 2 and 3.
- b) The PRF of the outputs can be varied over the range of 0.1 KHz to 10 MHz using the PRF controls.
- c) The relative delay between the pin 2 and 3 outputs can be varied by at least 500 nsec by the DELAY control.

The sealed clock module must be returned to Avtech for repair or replacement if the above conditions are not observed. The power supply board generates +24V DC to power the other modules. If the voltage is less than +24V, turn off the prime power and unsolder the lead from the 7824 regulator chip on the power supply board. Solder a 100 ohm 5 watt resistor to the 7824 output to ground and turn on the prime power. A voltage of +24 volts should be read. If the voltage is less then the power supply board is defective and should be repaired or replaced.

Schroff

06.13.91

-EW

-ER

-PN