



AVTECH ELECTROSYSTEMS LTD.

NANOSECOND WAVEFORM ELECTRONICS
SINCE 1975

P.O. BOX 265
OGDENSBURG, NY
U.S.A. 13669-0265
TEL: (315) 472-5270
FAX: (613) 226-2802

TEL: 1-800-265-6681
FAX: 1-800-561-1970
U.S.A. & CANADA

e-mail: info@avtechpulse.com

BOX 5120 STN. F
OTTAWA, ONTARIO
CANADA K2C 3H4
TEL: (613) 226-5772
FAX: (613) 226-2802

INSTRUCTIONS

MODEL AVO-9F-C PULSE GENERATOR

S.N. :

WARRANTY

Avtech Electrosystems Ltd. warrants products of its manufacture to be free from defects in material and workmanship under conditions of normal use. If, within one year after delivery to the original owner, and after prepaid return by the original owner, this Avtech product is found to be defective, Avtech shall at its option repair or replace said defective item. This warranty does not apply to units which have been disassembled, modified or subjected to conditions exceeding the applicable specifications or ratings. This warranty is the extent of the obligation or liability assumed by Avtech with respect to this product and no other warranty or guarantee is either expressed or implied.

Fig. 1

PULSE GENERATOR TEST ARRANGEMENT

(AVX-S1 MODULE REMOVED)

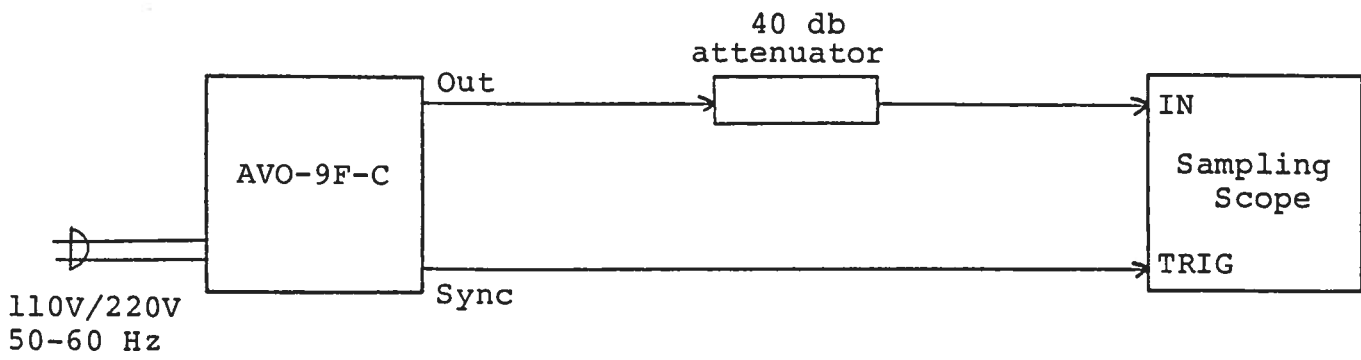

Notes:

- 1) The bandwidth capability of components and instruments used to display the pulse generator output signal (attenuators, cables, connectors, etc.) should exceed ten gigahertz.
- 2) The use of 40 dB attenuator at the sampling scope vertical input channel will insure a peak input signal to the sampling scope of less than one Volt.
- 3) The SYNC output provides a 50 mV sine wave (to 50 Ohms).
- 4) To obtain a stable output display the PRF RANGE and PRF controls on the front panel should be set mid-range while the FREQUENCY RANGE switch may be in either range. The front panel TRIG toggle switch should be in the INT position. The pulse width control should be set mid-range while the amplitude and TR-TF controls should be set maximum clockwise. The prime power should be turned on and the scope triggering controls adjusted to obtain a stable display. The PRF range switch and PRF control may then be adjusted to obtain the desired output PRF.
- 5) For operation below 100 MHz the frequency range should be in the LOW position while for operation above 100 MHz the switch should be in the HIGH position. However, position of this switch is not critical.
- 6) Clockwise rotation of the PW control increases the output duty cycle. Adjust for desired output pulse width (30 to 70% duty cycle).
- 7) The desired output amplitude is controlled primarily by the AMP control and partially by the TR-TF control. The TR-TF control also serves to sharpen the rise and fall times and to flatten the pulse top. Several iterative adjustments of the AMP and TR-TF controls may be necessary to simultaneously obtain the desired output amplitude while maintaining excellent pulse rise-fall times and flatness.
- 8) To trigger externally, set the INT-EXT switch to EXT and connect a sine wave generator to the TRIG connector. The output PRF will equal the sine wave PRF. The sine wave amplitude should be set at 0.3 VRMS.

- 9) The AVO-9F-C unit can be converted from 120 to 240V 50-60 Hz operation by adjusting the voltage selector card in the rear panel fused voltage selector-cable connector assembly.
- 10) For additional assistance:
Tel: (613) 226-5772
Fax: (613) 226-2802

Fig. 2

PULSE GENERATOR TEST ARRANGEMENT

(AVX-S1 MODULE CONNECTED)

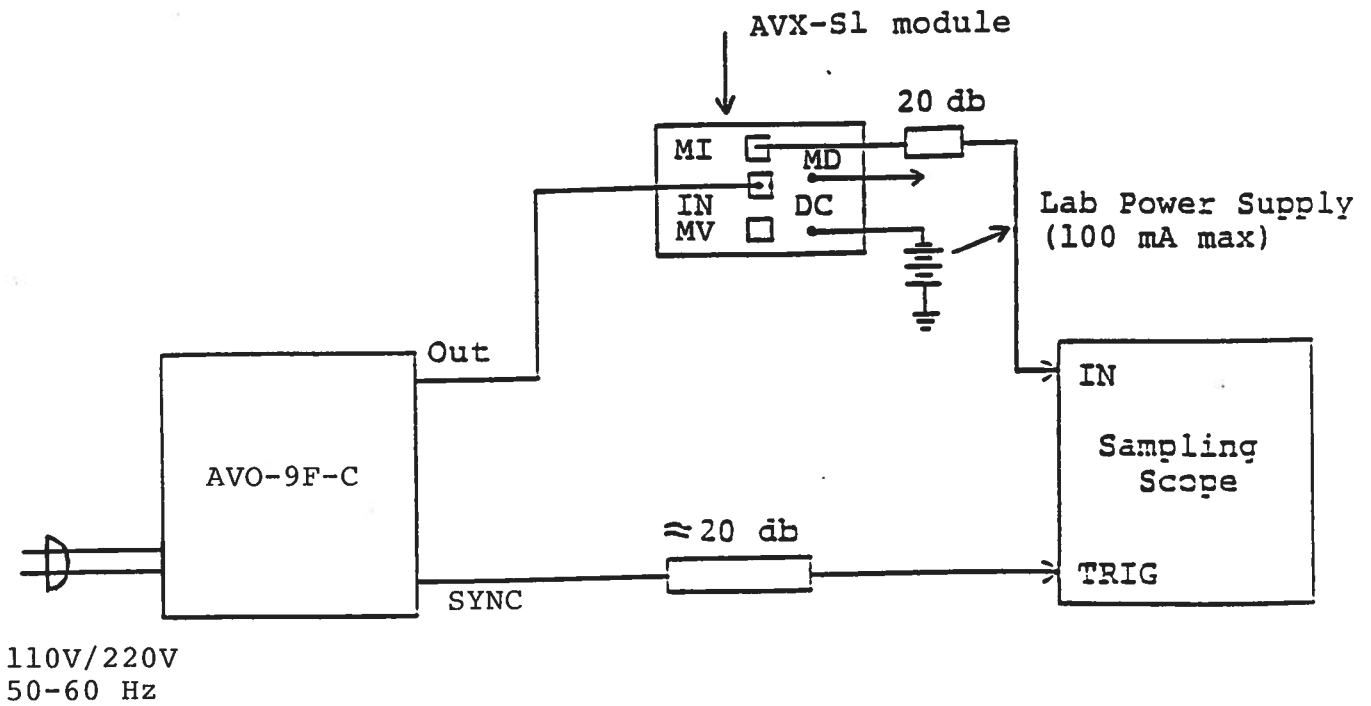

Notes:

- 1) A general description of the AVX-S1 module is given in the enclosed data sheet.
- 2) The AVX-S1 module should be connected to the AVO-9F-C mainframe via the supplied 24" RG174 cable. The diode current may be monitored by connecting the MI and MV output ports to the sampling scope via 20 dB attenuators.
- 3) CAUTION: It is important to note that the AVO-9F-C mainframe is AC-coupled and will operate with high duty cycles (eg. 30-70%). As a consequence, significant reverse voltages may be applied to the diode. This condition can be partially alleviated by the application of a negative DC bias to the diode (but do not exceed 100 mA). The DC offset (or bias) should be applied before the pulse signal is applied. A low-level pulse is then applied and the amplitude slowly increased while monitoring the MV output (see 6 below) to insure that the diode does not become reversed biased (see Fig. 3). Note that the mainframe may provide a peak to peak output voltage as high as 10 Volts and this will aggravate the reverse voltage problem and cause the forward peak current to exceed 100 mA. It may therefore be necessary to place a 6 dB attenuator on the line connecting the mainframe and the AVX-S1 module to limit the peak to peak voltage to less than 5 Volts.
- 4) The DC terminal of the bias insertion must either be shorted to ground (if a DC offset is not required) or a DC power supply must be applied. The laser diode will not function if the DC terminal is open circuited. Note that the DC current must not exceed -100 mA.
CAUTION: See 2) above.
- 5) The MI port must be terminated into 50 Ohms. Note that a 20 dB attenuator should be placed between the AVX-S MI output and the scope input in order to limit the maximum input amplitude to less than 500 mV.
- 6) The diode current I_D (Amps) and the MI and MV output voltages are related as follows:

$$I_D = 0.2 (V_{MI} - V_{MV})$$

- 7) The laser diode voltage is given by the following:

$$V_D = 10 V_{MV}$$

PR-51 --- 51

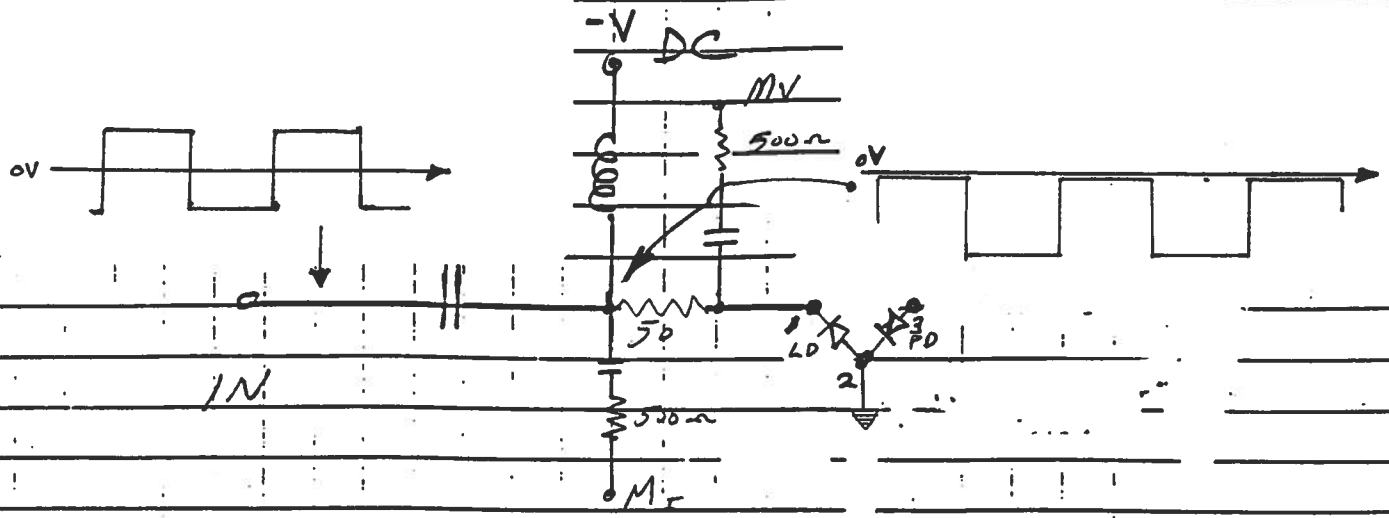
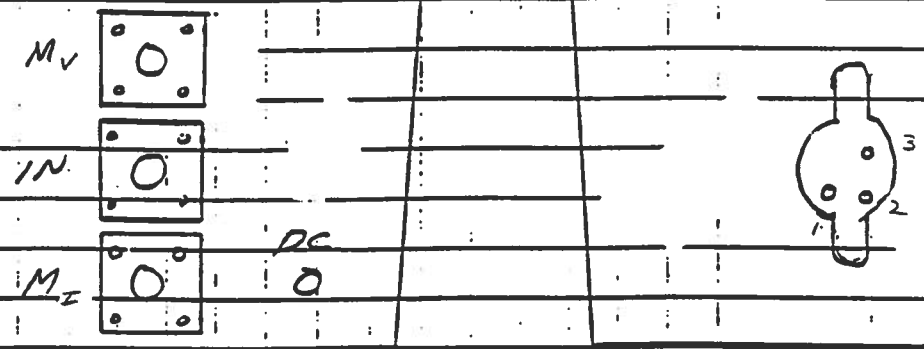

FIG. 3. FUNCTIONAL EQUIV. Ckt.



PR-51

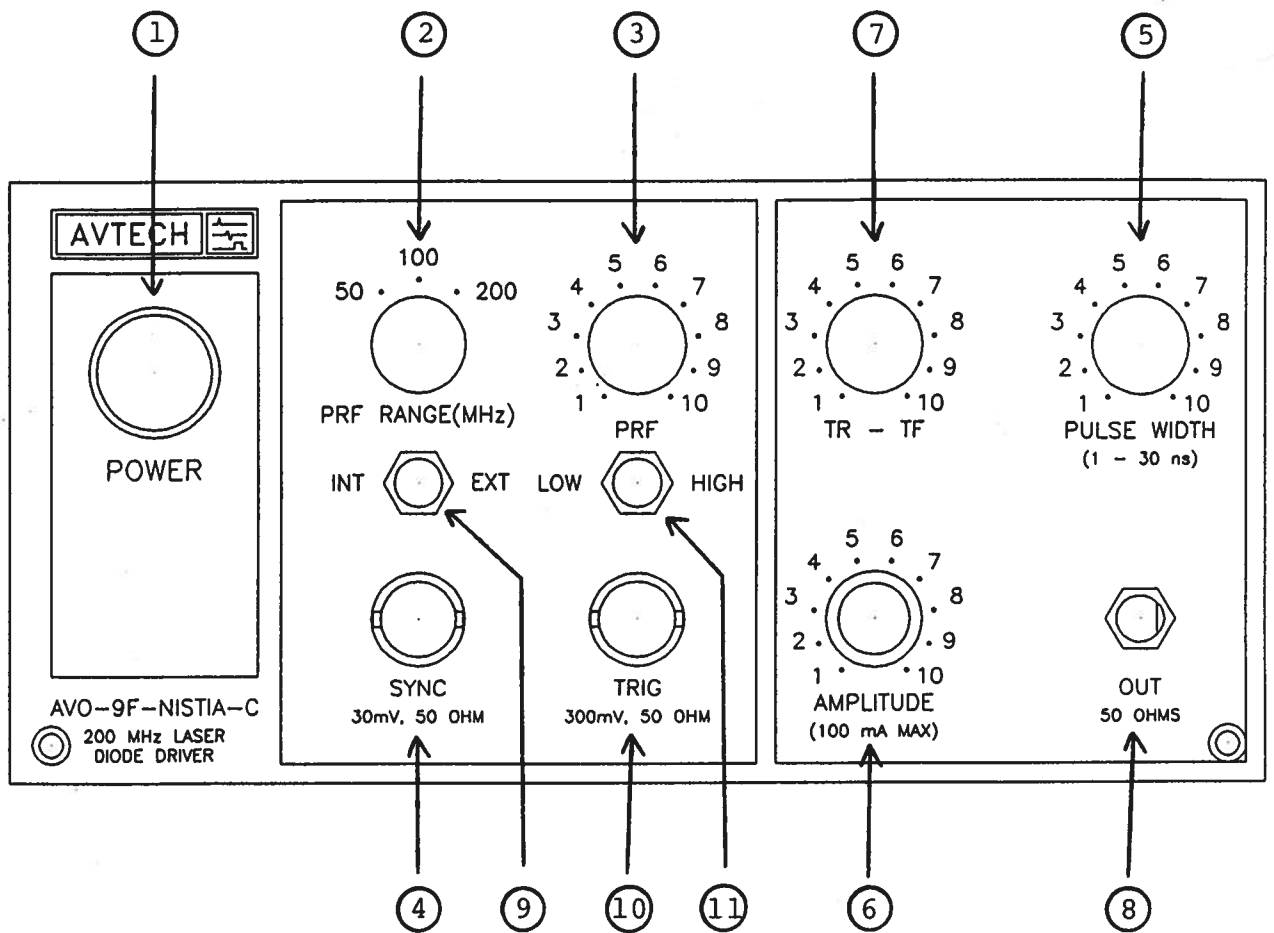

Fig. 4

FRONT PANEL CONTROLS

- (1) ON-OFF Switch. Applies basic prime power to all stages.
- (2) PRF Control. PRF RANGE and PRF controls determine
- (3) output PRF as follows:

	PRF MIN	PRF MAX
Range 1	25 MHz	75
Range 2	50	125
Range 3	100	200

- (4) SYNC Output. This output is approximately coincident with the main output (8) and is used to trigger the sampling scope time base. The output is a 50 mV sine wave capable of driving a fifty Ohm load.
- (5) PW Control. One turn controls which vary the output pulse width (or duty cycle from about 30 to 70%).
- (6) AMP Control. A one turn control which varies the output pulse amplitude from 0 to max output to a fifty Ohm load.
- (7) TR-TF. Controls flatness of pulse top and rise and fall time. Turn counter clockwise to smooth top and to decrease rise, fall time.
- (8) OUT Connector. SMA connector provides output to a fifty Ohm load.
- (9) EXT-INT Control. With this toggle switch in the INT position, the PRF of the unit is controlled via an internal clock which in turn is controlled by the PRF RANGE and PRF controls. With the toggle switch in the EXT position, the unit requires a 0.3 V RMS sine wave applied at the TRIG input in order to trigger the output stages. In addition, in this mode, the scope time base must be triggered by the external trigger source.
- (10) TRIG Input. The external trigger signal is applied at this input when the EXT-INT toggle switch is in the EXT position.
- (11) FREQUENCY (LOW-HIGH). For operation below 100 MHz switch should be in the LOW position. For operation above 100 MHz switch should be in the HIGH position (in order to obtain fastest rise time and smoothest pulse shape).

Fig. 5

BACK PANEL CONTROLS

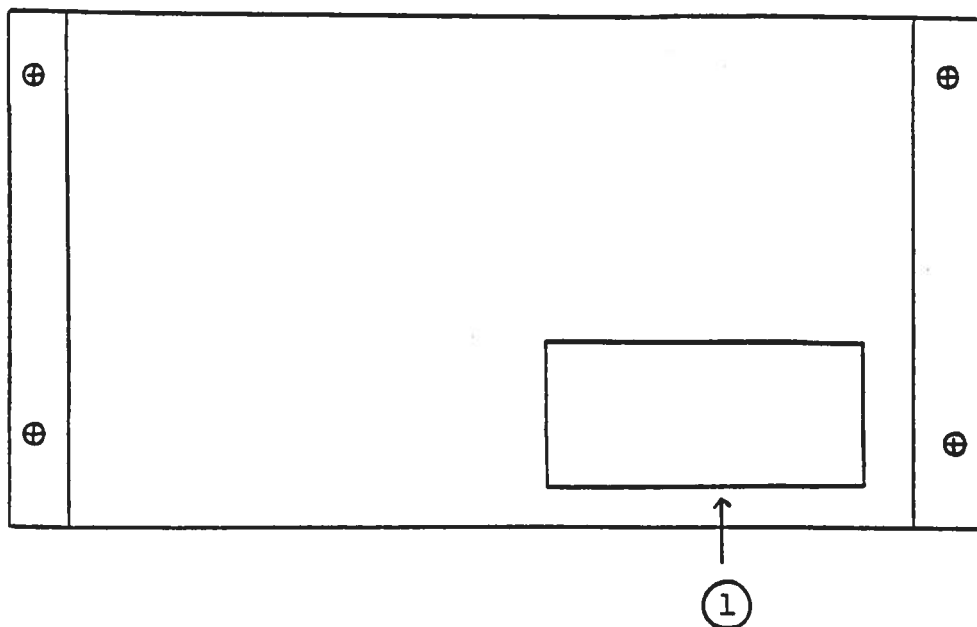

- (1) FUSED CONNECTOR, VOLTAGE SELECTOR. The detachable power cord is connected at this point. In addition, the removable cord is adjusted to select the desired input operating voltage. The unit also contains the main power fuse (0.5 Amp SB).

Fig. 6

SYSTEM BLOCK DIAGRAM

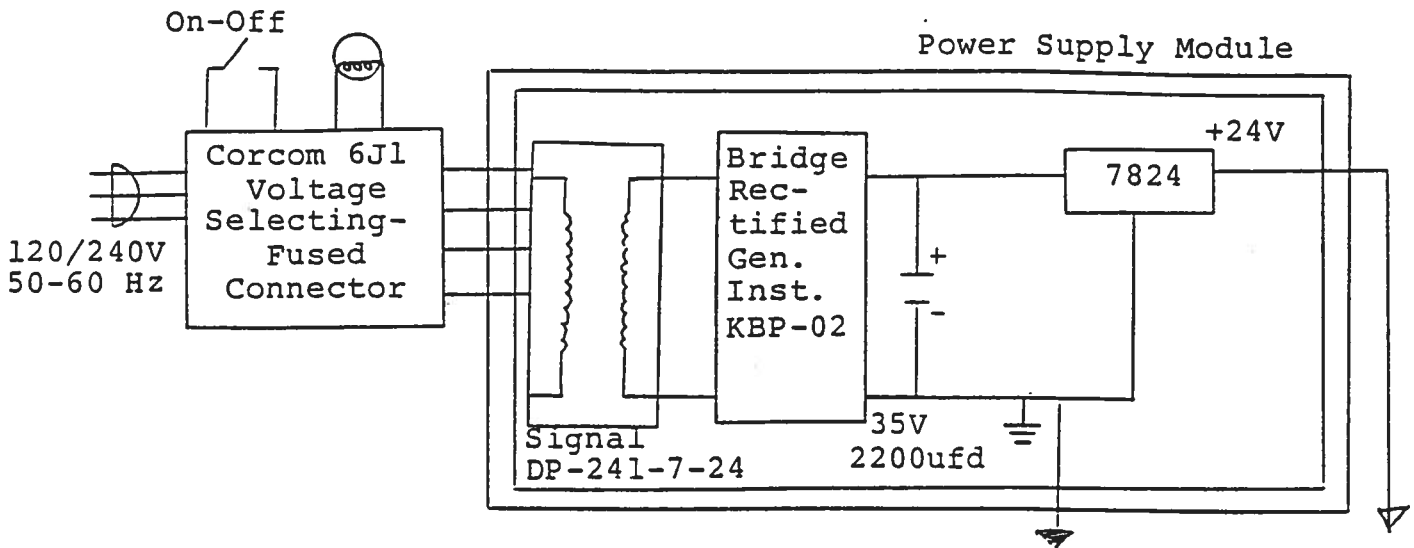

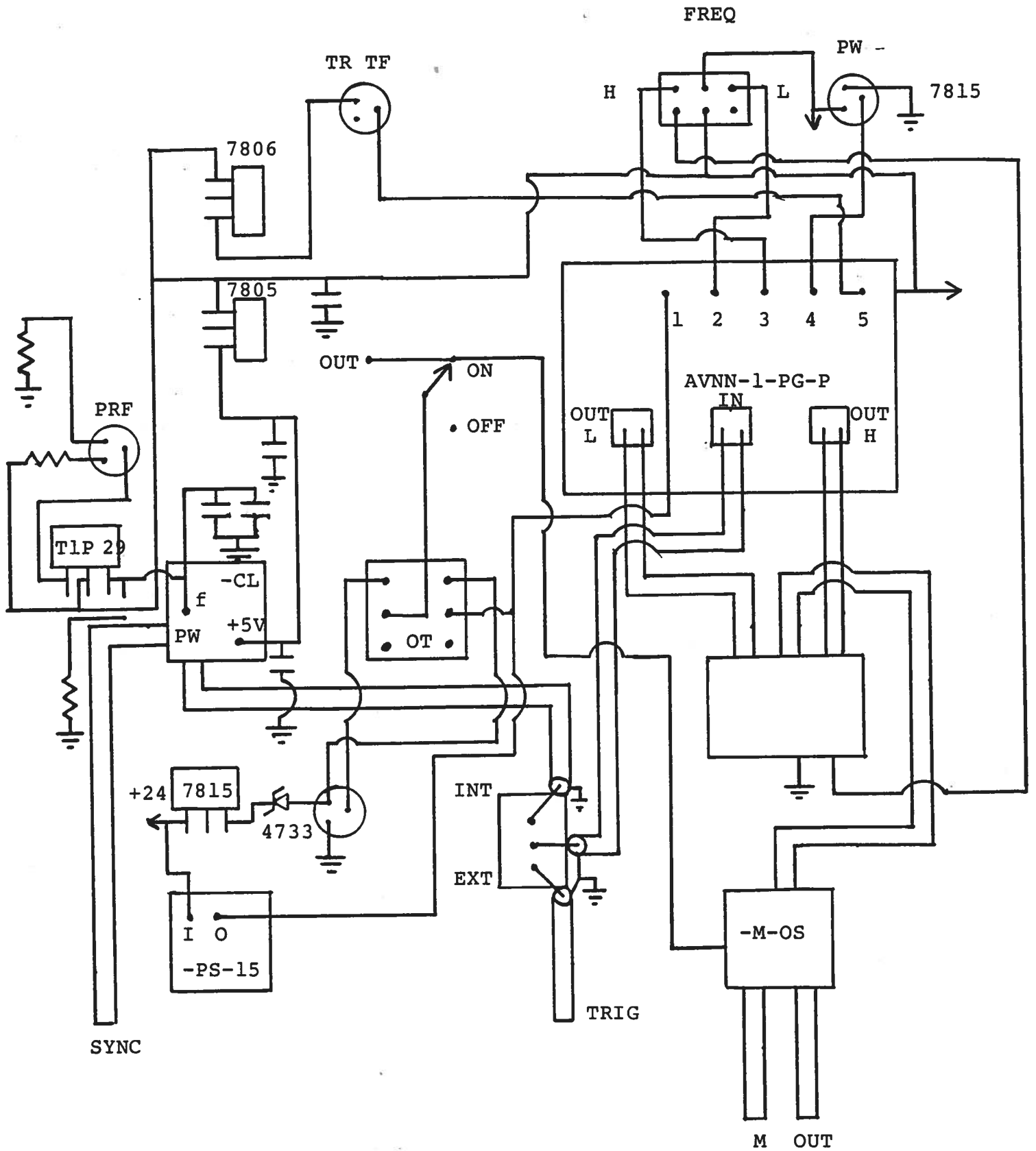

AVNN-1-C-M-OT BLOCK DIAGRAM

SYSTEM DESCRIPTION AND REPAIR PROCEDURE

The AVO-9F-C consists of a pulse generator module (AVO-9F-PG), a clock module (-CL), a -15V power supply module (-PS-15), a coaxial switch (RSM20) and a power supply board which supplies +24 Volts (800 mA max) to the pulse generator modules. In the event that the unit malfunctions, remove the instrument cover by removing the four Phillips screws on the back of the unit. The top may then be slid off. Measure the voltage at the +24V pin of the PG module. If this voltage is substantially less than +24 Volts, unsolder the line connecting the power supply and PG modules and connect 50 Ohm 10 W load to the PS output. The voltage across this load should be about +24 V DC. If this voltage is substantially less than 24 Volts the PS module is defective and should be repaired or replaced. If the voltage across the resistor is near 24 Volts, then the PG module should be replaced or repaired. The sealed PG module must be returned to Avtech for repair (or replacement). The clock module provides a 0.3 V RMS sine wave to trigger the PG module and a 30 mV sine wave to trigger the sampling scope display device. The clock module is powered by +5.0V supplied by the PG module. With the INT-EXT switch in the EXT position, the clock module is disconnected from the PG module.

The sealed clock module must be returned to Avtech for repair or replacement if the above conditions are not observed.

May 3/96

Ed. a.

Disk: AVO-9

Name: 9FC.INS