



AVTECH ELECTROSYSTEMS LTD.

NANOSECOND WAVEFORM ELECTRONICS
SINCE 1975

□ P.O. BOX 265
OGDENSBURG, NY
U.S.A. 13669-0265
TEL: (315) 472-5270
FAX: (613) 226-2802

TEL: 1-800-265-6681
FAX: 1-800-561-1970

e-mail: info@avtechpulse.com
<http://www.avtechpulse.com>

□ P.O. BOX 5120 STN. F
OTTAWA, ONTARIO
CANADA K2C 3H4
TEL: (613) 226-5772
FAX: (613) 226-2802

INSTRUCTIONS

MODEL AVOZ-B2-C PULSE GENERATOR

S.N.:

WARRANTY

Avtech Electrosystems Ltd. warrants products of its manufacture to be free from defects in material and workmanship under conditions of normal use. If, within one year after delivery to the original owner, and after prepaid return by the original owner, this Avtech product is found to be defective, Avtech shall at its option repair or replace said defective item. This warranty does not apply to units which have been disassembled, modified or subjected to conditions exceeding the applicable specifications or ratings. This warranty is the extent of the obligation assumed by Avtech with respect to this product and no other warranty or guarantee is either expressed or implied.

TECHNICAL SUPPORT

Phone: 613-226-5772 or 1-800-265-6681

Fax: 613-226-2802 or 1-800-561-1970

E-mail: info@avtechpulse.com

World Wide Web: <http://www.avtechpulse.com>

TABLE OF CONTENTS

WARRANTY.....	2
TABLE OF CONTENTS	3
FIG. 1: PULSE GENERATOR TEST ARRANGEMENT.....	4
GENERAL OPERATING INSTRUCTIONS	5
FIG. 2: FRONT PANEL CONTROLS	7
FRONT PANEL CONTROLS	8
FIG. 3: BACK PANEL CONTROLS.....	10
BACK PANEL CONTROLS.....	11
SYSTEM DESCRIPTION AND REPAIR PROCEDURE	12
POWER SUPPLY AND FUSE REPLACEMENT.....	13
PERFORMANCE CHECK SHEET	15

FIG. 1: PULSE GENERATOR TEST ARRANGEMENT

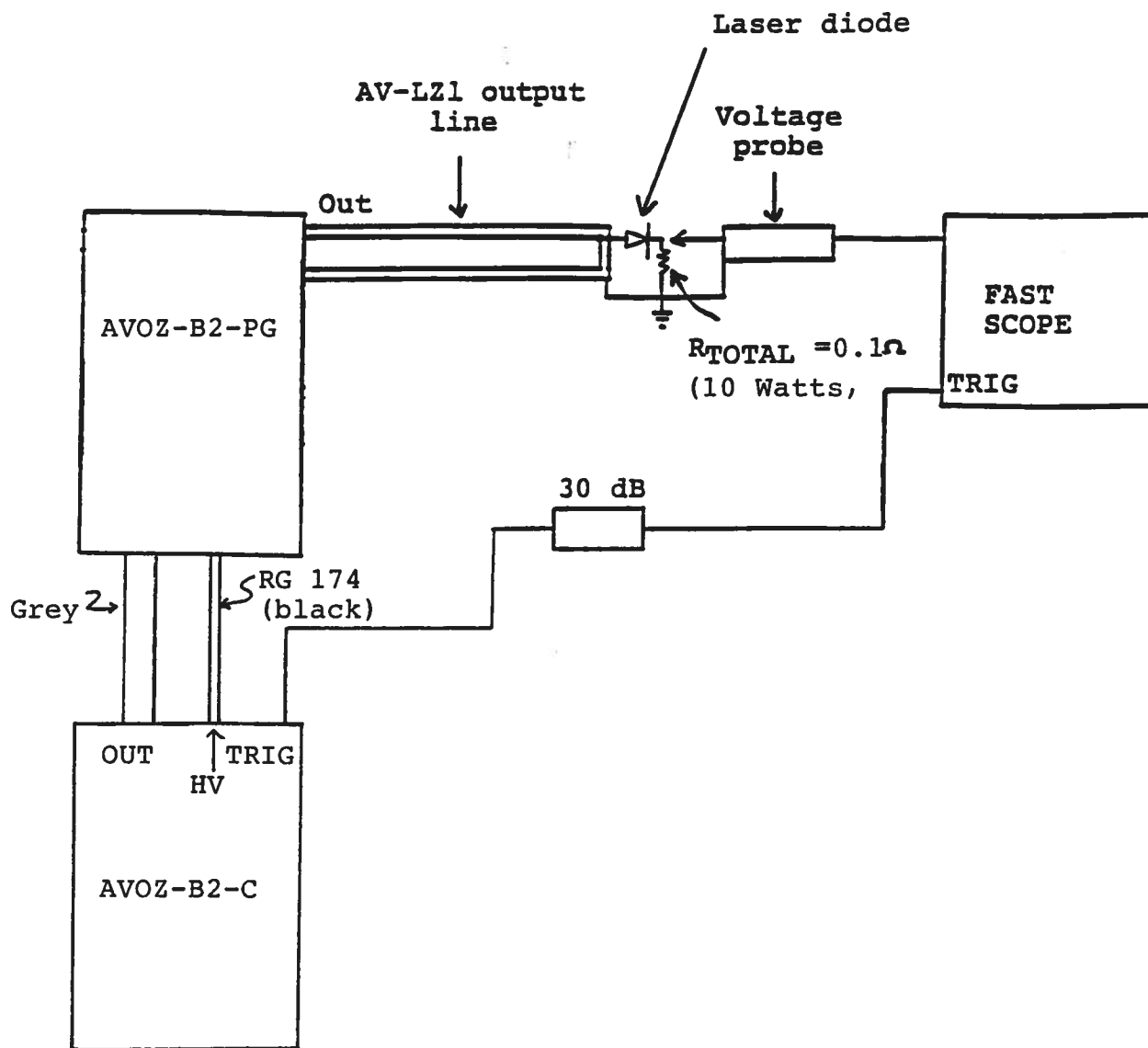

GENERAL OPERATING INSTRUCTIONS

- 1) The equipment should be connected in the general fashion shown above. Since the AVOZ unit provides an output pulse rise time as low as 10 ns a fast oscilloscope (at least 50 MHz) should be used to display the waveform. Note that the multi-pin gray cable from the AVOZ-B2-PG module must be connected to the "OUT" terminal on the AVOZ-B2-C front panel and the black RG174 cable must be connected to the SMA HV connector.
- 2) The TRIG output channel provides TTL level signals. To avoid overdriving the TRIG input channel of some scopes, a 30 dB attenuator should be placed at the input to the scope trigger channel. The TRIG output precedes the main output when the front panel ADVANCE-DELAY switch is in the ADVANCE position. The TRIG output lags the main output when the switch is in the DELAY position.
- 3) To obtain a stable output display the PRF controls on the front panel should be set mid-range. The front panel TRIG toggle switch should be in the INT position. The front panel DELAY control and the scope triggering controls are then adjusted to obtain a stable output. The scope may then be used to set the desired PRF by rotating the PRF controls.
- 4) The -PG output module generates a 0 to 30 Volt voltage pulse to a load of 0.1 Ohms (or greater). The AV-LZ1 flexible output line which protrudes from the side of the AVOZ-B2-PG module has a characteristic impedance of one Ohm. The diode load and a non-inductive load resistor should be solder connected to the end of the line as shown below (using extremely short lead lengths (eg. 0.2 cm) so as to reduce inductance). The series combination of the laser diode and the load resistor R_L should present 0.1 Ohm to the end of the line. If the load resistance exceeds 0.1 Ohms, the peak output current will be less than 300 Amps. The diode current may be monitored by monitoring the voltage across the resistor (or by means of a current probe). An ultra fast rectifier diode (eg. MBR160) may be placed across the laser diode to protect against reverse transients.

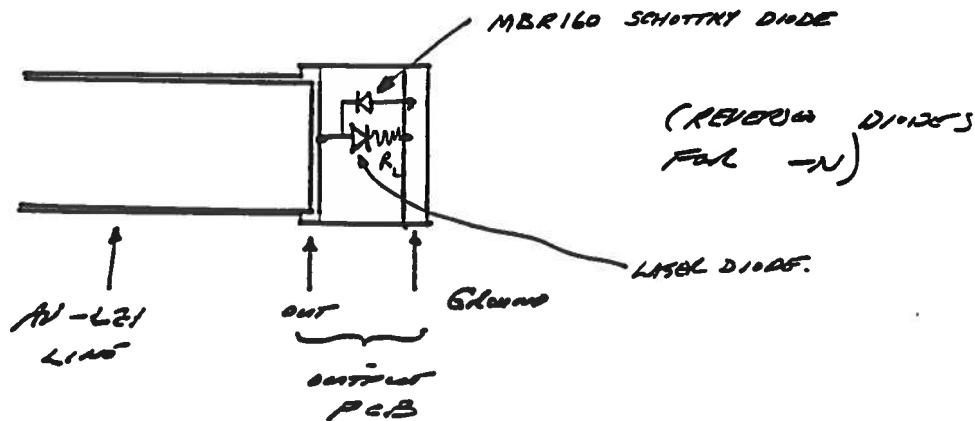

- 5) The output pulse width is controlled by means of the front panel one turn PW control. To voltage control the pulse width, set the rear panel switch in the EXT position and apply 0 to +10 Volts between terminal A and ground ($R_{IN} \geq 10K$). (option).

CAUTION: The output duty cycle must not exceed 0.1% (e.g. for PW = 500 ns, PRF max = 2.0 kHz) or the unit may be damaged.

- 6) The output pulse amplitude is controlled by means of the front panel one turn AMP control. To voltage control the output, set the rear panel switch in the EXT position and apply 0 to +10 Volts between terminal A and ground ($R_{IN} \geq 10K$). (option).

- 7) AVOZ units with a serial number higher than 6500 are protected by an automatic overload protective circuit which controls the front panel overload light. If the unit is overloaded (by operating at an exceedingly high duty cycle or by operating into a short circuit), the protective circuit will turn the output of the instrument OFF and turn the indicator light ON. The light will stay ON (i.e. output OFF) for about 5 seconds after which the instrument will attempt to turn ON (i.e. light OFF) for about 1 second. If the overload condition persists, the instrument will turn OFF again (i.e. light ON) for another 5 seconds. If the overload condition has been removed, the instrument will turn on and resume normal operation. Overload conditions may be removed by:

- 1) Reducing PRF (i.e. switch to a lower range)
- 2) Reducing pulse width (i.e. switch to a lower range)
- 3) Removing output load short circuit (if any)

- 8) The unit can be converted from 110 to 220V 50-60 Hz operation by adjusting the voltage selector card in the rear panel fused voltage selector-cable connector assembly.

- 9) For additional assistance:

Tel: (613) 226-5772
Fax: (613) 226-2802
Email: info@avtechpulse.com

FIG. 2: FRONT PANEL CONTROLS

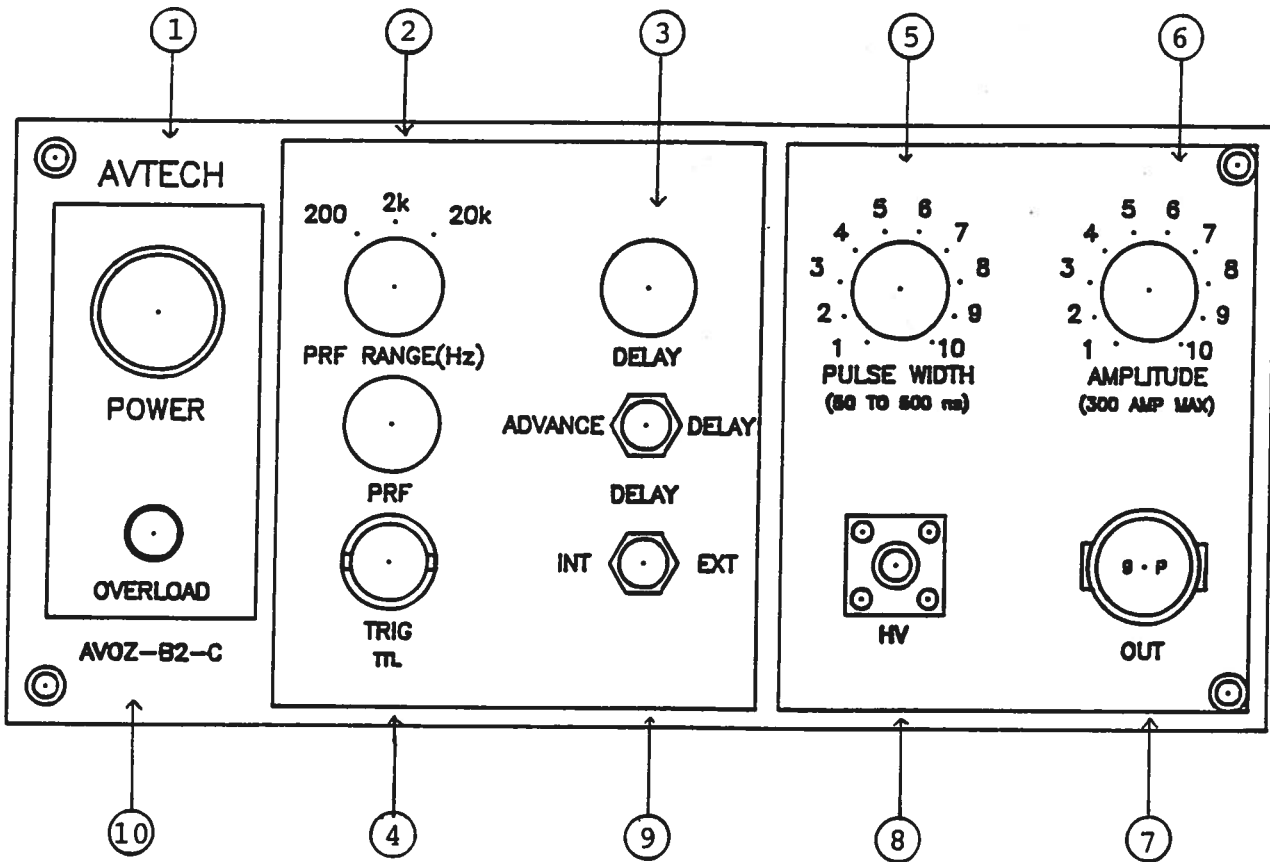

FRONT PANEL CONTROLS

- (1) ON-OFF Switch. Applies basic prime power to all stages.
- (2) PRF Control. Varies PRF as follows:

RANGE 1	20 Hz - 200 Hz
RANGE 2	200 Hz - 2 kHz
RANGE 3	2 kHz - 20 kHz
- (3) DELAY Control. Controls the relative delay between the reference output pulse provided at the TRIG output (4) and the main output (7). This delay is variable over the range of 0 to about 1.0 us. The TRIG output precedes the main output when the ADVANCE-DELAY switch is in the ADVANCE position and lags when the switch is in the DELAY position.
- (4) TRIG Output. This output precedes the main output (7) and is used to trigger the sampling scope time base. The output is a TTL level 100 ns (approx) pulse capable of driving a fifty Ohm load.
- (5) PW Control. A one turn control which varies the output pulse width from 50 ns to 500 ns.
- (6) AMP Control. The output pulse amplitude is controlled by means of the one turn potentiometer (AMP).
- (7) OUT. The gray multi-pin cable from the -PG module must be connected to this connector.
- (8) HV. The black RG 174 cable from the -PG output module must be connected to this SMA connector.
- (9) EXT-INT Control. With this toggle switch in the INT position, the PRF of the unit is controlled via an internal clock which in turn is controlled by the PRF controls. With the toggle switch in the EXT position, the unit requires a 0.2 us TTL level pulse applied at the TRIG input in order to trigger the output stages.

(10) AVOZ units with a serial number higher than 5600 are protected by an automatic overload protective circuit which controls the front panel overload light. If the unit is overloaded (by operating at an exceedingly high duty cycle or by operating into a short circuit), the protective circuit will turn the output of the instrument OFF and turn the indicator light ON. The light will stay ON (i.e. output OFF) for about 5 seconds after which the instrument will attempt to turn ON (i.e. light OFF) for about 1 second. If the overload condition persists, the instrument will turn OFF again (i.e. light ON) for another 5 seconds. If the overload condition has been removed, the instrument will turn on and resume normal operation. Overload conditions may be removed by:

- 1) Reducing PRF (i.e. switch to a lower range)
- 2) Reducing pulse width (i.e. switch to a lower range)
- 3) Removing output load short circuit (if any)

FIG. 3: BACK PANEL CONTROLS

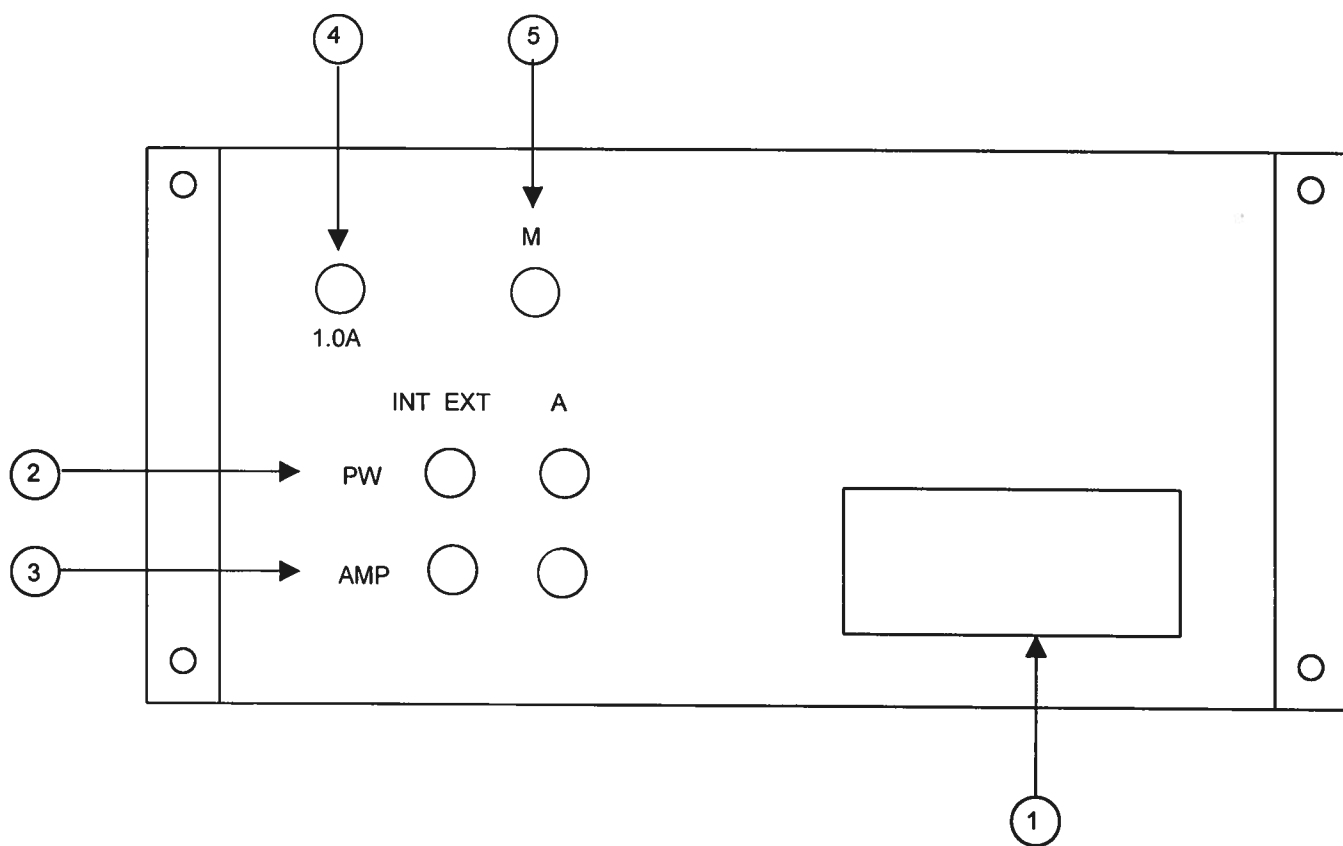

BACK PANEL CONTROLS

- (1) FUSED CONNECTOR, VOLTAGE SELECTOR. The detachable power cord is connected at this point. In addition, the removable cord is adjusted to select the desired input operating voltage. The unit also contains the main power fuse (0.5 A SB).
- (2) EA. To voltage control the output amplitude, set the switch in the EXT position and apply 0 to +10 Volts between terminal A and ground ($R_{IN} \geq 10K$). (option).
- (3) EW. To voltage control the output pulse width, set the switch in the EXT position and apply 0 to +10 Volts between terminal A and ground ($R_{IN} \geq 10K$). (option).
- (4) 1.0A SB. This fuse limits the DC prime power supplied to the output stage and will blow in the case of severe overloading.
- (5) M OPTION. SMA connector provides an output voltage pulse (to 50 Ohms or $R_L \geq 1 K$) with an amplitude which is proportional to the load current pulse amplitude and a pulse width which equals the output pulse width.
 - (a) 50 OHM M LOAD: $I_{OUT} = 10 V_M$ (Amps & Volts)
 - (b) OPEN CIRCUIT M LOAD: $I_{OUT} = 5 V_M$ (Amps & Volts)

SYSTEM DESCRIPTION AND REPAIR PROCEDURE

The AVOZ-A-C unit consists of the following basic modules:

- 1) AVOZ-A-PG pulse generator module
- 2) AVOZ-A-PS power supply module
- 3) AVOZ-A-CL clock module
- 4) +24V power supply board

The modules are interconnected as shown in Fig. 4. The clock module controls the output PRF and the relative delay between the main output and the TRIG output. The PG pulse generator module generates the output pulse. In the event of an instrument malfunction, it is most likely that the rear panel 1.0A SB fuse may have failed due to an output short circuit condition or to a high duty cycle condition. If the fuse has not blown, then the four Phillips screws on the back panel should be removed. The top cover may then be slid off and the operation of the clock and power supply modules checked. The clock module is functioning properly if:

- a) 0.1 us TTL level outputs are observed at pins 2 and 3.
- b) The PRF of the outputs can be varied over the range of 2 Hz to 20.0 kHz using the PRF and PRF FINE controls.
- c) The relative delay between the pin 2 and 3 outputs can be varied by at least 1 us by the DELAY control.

The sealed clock module must be returned to Avtech for repair or replacement if the above conditions are not observed. The power supply board generates +24V DC to power the other modules. If the voltage is less than +24V, turn off the prime power and unsolder the lead from the 7824 regulator chip on the power supply board. Solder a 100 Ohm 5 Watt resistor to the 7824 output to ground and turn on the prime power. A voltage of +24 Volts should be read. If the voltage is less then the power supply board is defective and should be repaired or replaced.

POWER SUPPLY AND FUSE REPLACEMENT

This instrument has three fuses (plus one spare). One, which protects the AC input, is located in the rear-panel power entry module, as described in the “Rear Panel Controls” section of this manual. If the power appears to have failed, check the AC fuse first.

The other two fuses (plus one spare) are located on the internal DC power supply, as shown below:

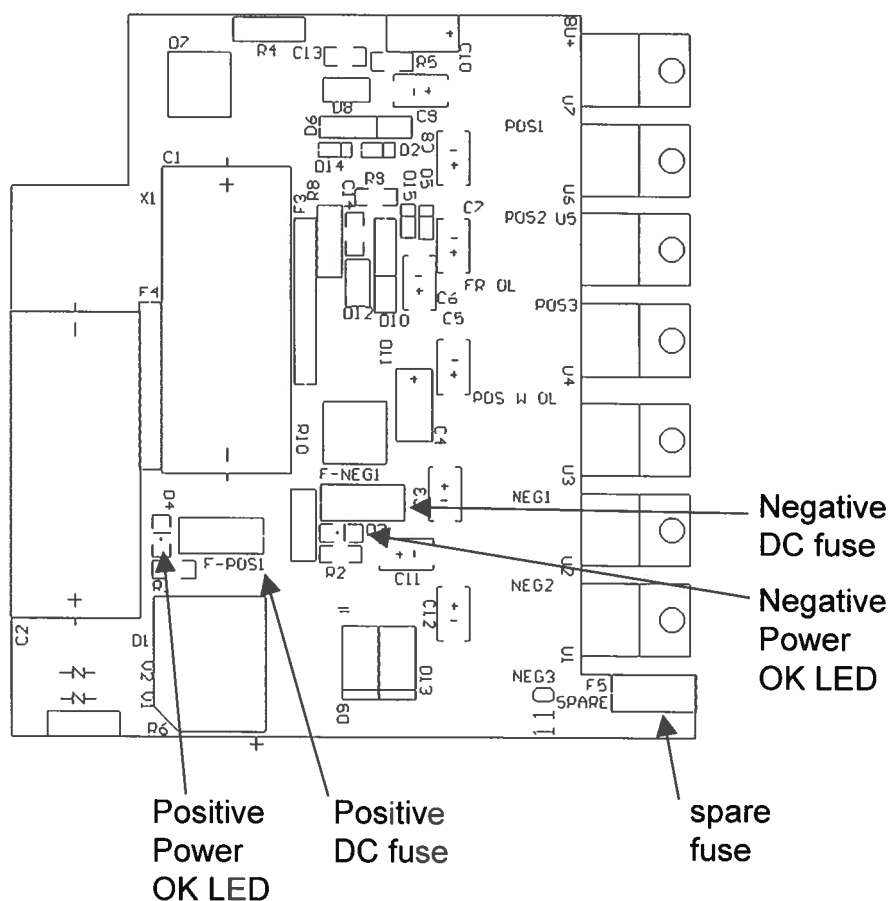

The spare fuse may be used to replace one of the other fuses, if required.

The three fuses on this circuit board are 0.5A slow-blow fuses, Littlefuse part number R452.500. (This fuse can be ordered from Digikey, www.digikey.com. The Digikey part number is F1341CT-ND).

If you suspect that the DC fuses are blown, follow this procedure:

1. Remove the top cover, by removing the four Phillips screws on the top cover and then sliding the cover back and off.
2. Locate the two "Power OK" LEDs on the power supply circuit board, as illustrated above.
3. Turn on the instrument.
4. Observe the "Power OK" LEDs. If the fuses are not blown, the two LEDs will be lit (bright red). If one of the LEDs is not lit, the fuse next to it has blown.
5. Turn off the instrument.
6. If a fuse is blown, use needle-nose pliers to remove the blown fuse from its surface-mount holder.
7. Replace the fuse.