

# AVTECH ELECTROSYSTEMS LTD.

NANOSECOND WAVEFORM ELECTRONICS  
ENGINEERING - MANUFACTURING

□ P.O. BOX 265  
OGDENSBURG  
NEW YORK  
13669  
(315) 472-5270

☒ BOX 5120, STN. "F"  
OTTAWA, ONTARIO  
CANADA K2C 3H4  
TEL: (613) 226-5772  
FAX: (613) 226-2802  
TELEX: 053-4591

## INSTRUCTIONS

MODEL AVP-2S-C-CM1-OS PULSE GENERATOR

S.N.:

## WARRANTY

Avtech Electrosystems Ltd. warrants products of its manufacture to be free from defects in material and workmanship under conditions of normal use. If, within one year after delivery to the original owner, and after prepaid return by the original owner, this Avtech product is found to be defective, Avtech shall at its option repair or replace said defective item. This warranty does not apply to units which have been disassembled, modified or subjected to conditions exceeding the applicable specifications or ratings. This warranty is the extent of the obligation or liability assumed by Avtech with respect to this product and no other warranty or guarantee is either expressed or implied.

Fig. 1

PULSE GENERATOR TEST ARRANGEMENT

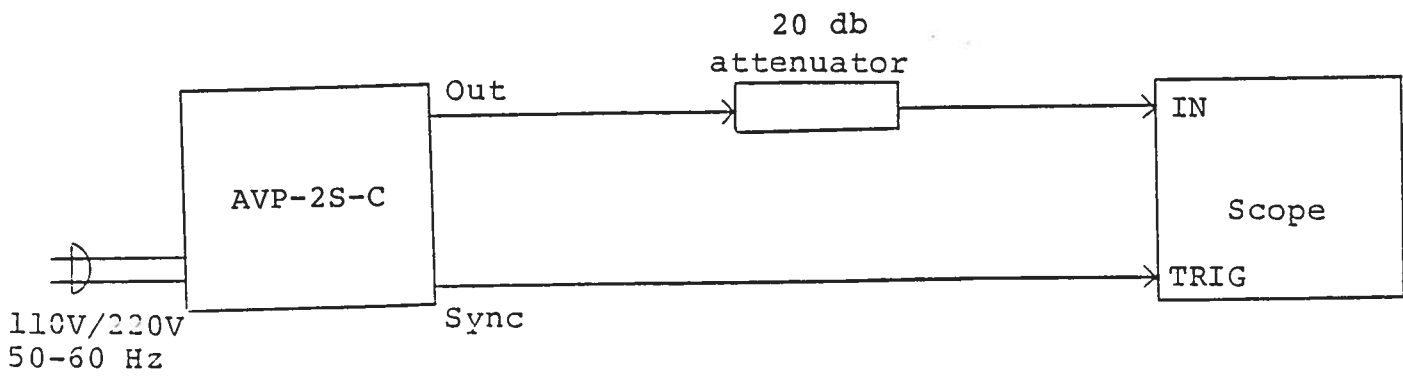

Notes:

- 1) The bandwidth capability of components and instruments used to display the pulse generator output signal (attenuators, cables, connectors, etc.) should exceed 18 GHz.
- 2) The use of 20 db attenuator at the scope vertical input channel will insure a peak input signal to the scope of less than one volt.
- 3) The sync output channel provides a 500 mV 20 nsec wide pulse to fifty ohms. The sampling scope should be set to trigger on the positive edge of the sync pulse.
- 4) To obtain a stable output display the PW and PRF controls on the front panel should be set mid range. The front panel TRIG toggle switch should be in the INT position. The DELAY controls and the scope triggering controls are then adjusted to obtain a stable output. The scope may then be used to set the desired PRF by rotating the PRF controls.
- 5) The output pulse width is controlled by means of the front panel one turn PW control.
- 6) The output pulse amplitude is controlled by means of the front panel one turn AMP control. Some properties of the output pulse may change as a function of the amplitude pot setting. For some demanding applications, it may be desirable to use a combination of external attenuators and the amplitude pot to achieve the desired output amplitude.
- 7) To voltage control the output pulse width, remove the jumper wire between banana plugs A and B on the back panel and apply 0 to +10V to connector B ( $R_{IN} \gg 10K$ ). (option).
- 8) To voltage control the output amplitude, remove the jumper wire between banana plugs A and B on the back panel and apply 0 to +10V to connector B ( $R_{IN} \gg 10K$ ). (option).
- 9) For units with the OT or EO options, the output DC offset is variable from +5 to -5 volts by means of the front panel one turn OFFSET control. The offset control may be turned off by means of the rear panel ON-OFF OFFSET switch.
- 10) For units with the EO option, the output offset may be voltage controlled by removing the jumper wire between banana plugs A and B on the back panel and applying 0 to +10 volts to connector B ( $R_{IN} \gg 10K$ ).

- 11) An external clock may be used to control the output FRF of the AVP unit by setting the front panel TRIG toggle switch in the EXT position and applying a +200 mV ( $\pm 100$  mV) pulse (pulse width from 10 nsec to 0.5 usec) to the TRIG BNC connector input. For operation in this mode, the scope time base must also be triggered by the external clock rather than from the SYNC output.
- 12) The AVP-2S-C unit can be converted from 110 to 220V 50-60 Hz operation by adjusting the voltage selector card in the rear panel fused voltage selector-cable connector assembly.

Fig. 2

FRONT PANEL CONTROLS

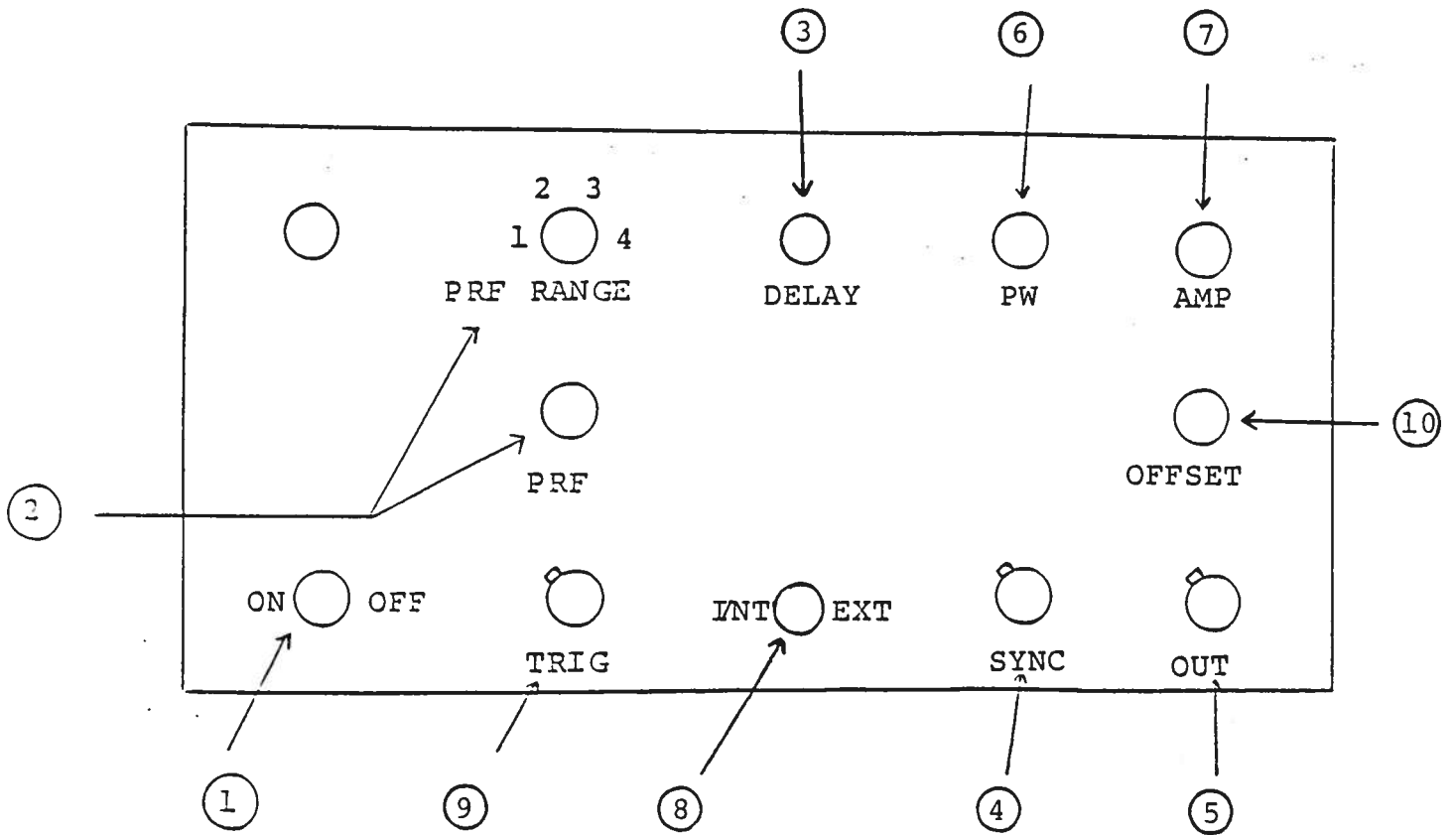

- (1) ON-OFF Switch. Applies basic prime power to all stages.
- (2) PRF Control. Varies PRF from 1.0 KHz to 1.0 MHz as follows:

Range 1	1.0 KHz	8 KHz
Range 2	8 KHz to	40 KHz
Range 3	40 KHz to	200 KHz
Range 4	200 KHz to	1.0 MHz
- (3) DELAY Control. Controls the relative delay between the reference output pulse provided at the SYNC output (4) the main output (5). This delay is variable over the range of 0 to about 150 nsec.
- (4) SYNC Output. This output precedes the main output (5) and is used to trigger the scope time base. The output is a 500 mV 20 nsec (approx.) pulse capable of driving a fifty ohm load. Set scope to trigger on positive edge.
- (5) OUT Connector. SMA connector provides output to a fifty ohm load.
- (6) PW Control. A one turn control which varies the output pulse width.
- (7) AMP Control. A one turn control which varies the output pulse amplitude.
- (8) EXT-INT Control. With this toggle switch in the INT position, the PRF of the AVP unit is controlled via an internal clock which in turn is controlled by the PRF controls. With the toggle switch in the EXT position, the AVP unit requires a +200 mV ( $\pm 100$  mV) pulse (pulse width 10 nsec to 0.5 usec) applied at the TRIG input in order to trigger the output stages. In addition, in this mode, the scope time base must be triggered by the external trigger source.
- (9) TRIG Input. The external trigger signal is applied at this input when the EXT-INT toggle switch is in the EXT position.
- (10) OFFSET. One turn control varies DC offset on output from  $\pm 5$  volts. (option).

Fig. 3

BACK PANEL CONTROLS

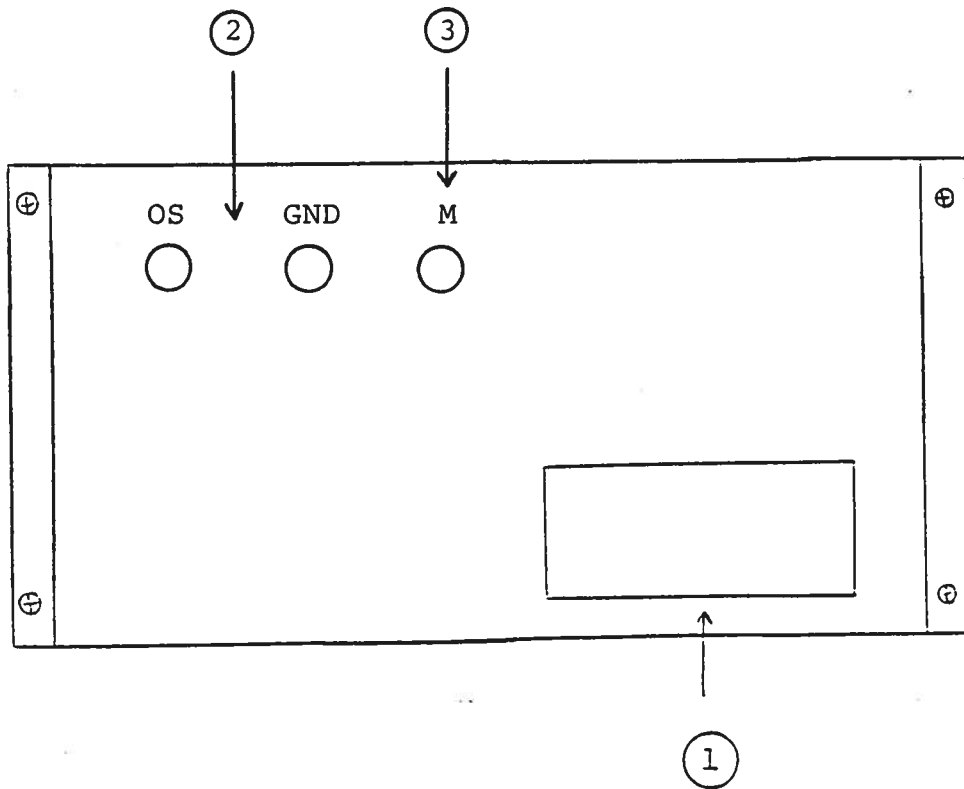



- (1) FUSED CONNECTOR, VOLTAGE SELECTOR. The detachable power cord is connected at this point. In addition, the removable cord is adjusted to select the desired input operating voltage. The unit also contains the main power fuse.
- (2) DC OFFSET Input. To DC offset the output pulse, connect a DC power supply set to the desired offset value to these terminals. The maximum allowable DC offset voltage is  $\pm 50$  volts.
- (3) MONITOR OUT M. Provides an attenuated ( $\times 10$ ) coincident replica of the main positive output pulse to fifty ohms. (option).

Fig. 4

SYSTEM BLOCK DIAGRAM

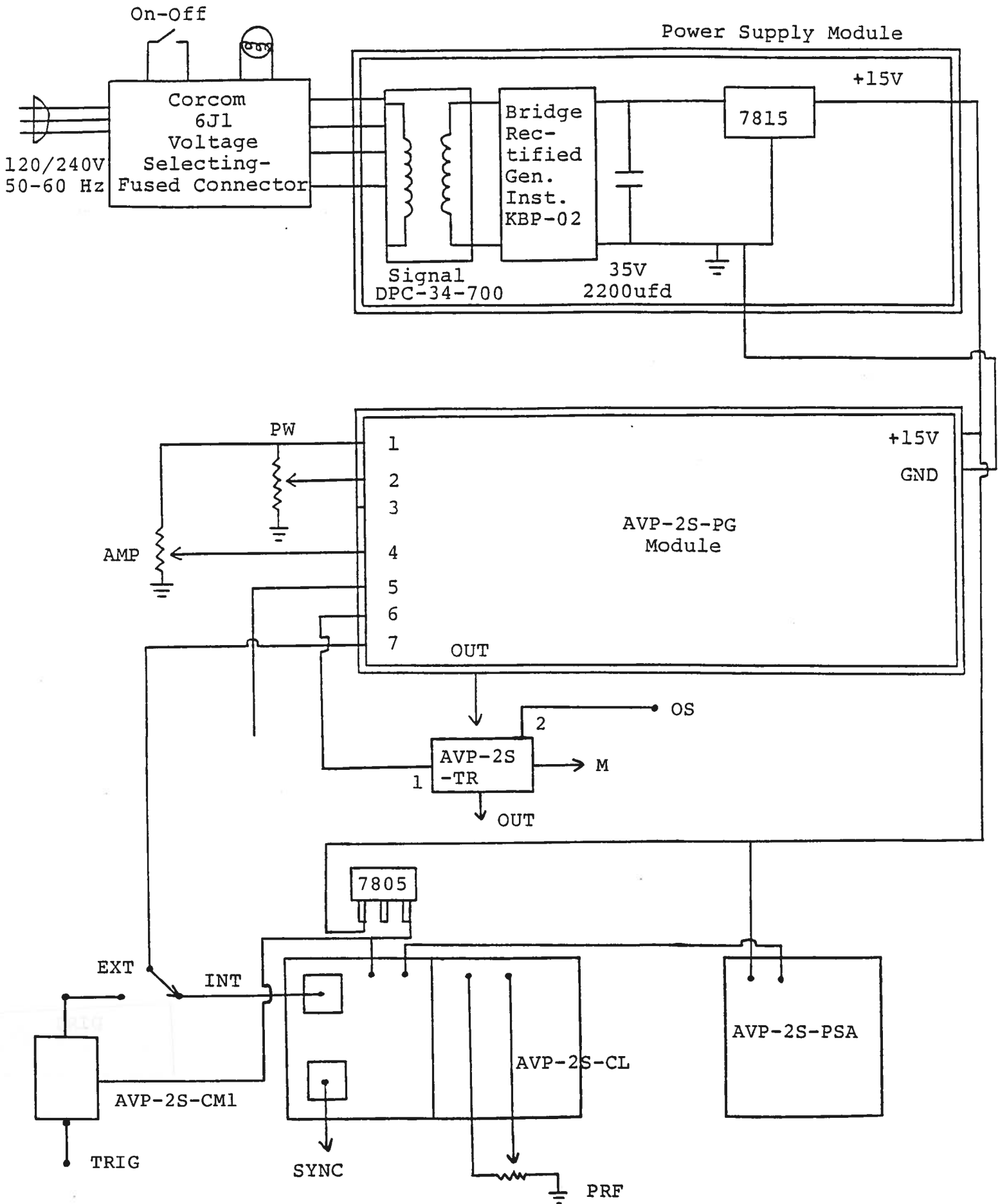

## SYSTEM DESCRIPTION AND REPAIR PROCEDURE

The AVP-2S-C consists of:

- a) AVP-2S-PG pulse generator module
- b) AVP-2S-CL clock module
- c) AVP-OT offset module (option)
- d) AVP-2S-PS -5.0 volt power supply module
- e) AVP-TR rise time module
- f) +15 volt power supply board

In the event that the unit malfunctions, remove the instrument cover by removing the four Phillips screws on the back of the unit. The top cover may then be slid off. Measure the voltage at the +15V pin of the PG module. If this voltage is substantially less than +15 volts, unsolder the line connecting the power supply and PG modules and connect 50 ohm 10 W load to the PS output. The voltage across this load should be about +15 V DC. If this voltage is substantially less than 15 volts the PS module is defective and should be repaired or replaced. If the voltage across the resistor is near 15 volts, then the PG module should be replaced or repaired. The sealed PG module must be returned to Avtech for repair (or replacement). The clock module provides a TTL level trigger pulse at pin 2 to trigger the PG module and a 20 nsec 500 mV sync pulse at pin 3 to trigger the sampling scope display device. The output at pin 3 precedes the output at pin 2 by almost 0 to 100 nsec depending on the DELAY control setting. With the INT-EXT switch in the EXT position, the clock module is disconnected from the PG module. The clock module is functioning properly if:

- a) TTL level and 20 nsec 500 mV outputs are observed at pins 2 and 3, respectively.
- b) The PRF of the outputs can be varied over the range of 1 KHz to 1 MHz using the PRF control.
- c) The relative delay between the pin 2 and 3 outputs can be varied by at least 500 nsec by the DELAY controls.

The sealed clock module must be returned to Avtech for repair or replacement if the above conditions are not observed.

Schroff

07.27.89

-EW

-EA

-OT

-EO

-M