

AVTECH ELECTROSYSTEMS LTD.

**NANOSECOND WAVEFORM ELECTRONICS
ENGINEERING . MANUFACTURING**

□ P.O. BOX 265
OGDENSBURG
NEW YORK
13669
(315) 472-5270

BOX 5120 STN. "F"
OTTAWA, ONTARIO
CANADA K2C 3H4
(613) 226-5772
TELEX 053-4591

INSTRUCTIONS

Model AVP-AV-2-C-WH1 Pulse Generator

S.N.:

WARRANTY

Avtech Electrosystems Ltd. warrants products of its manufacture to be free from defects in material and workmanship under conditions of normal use. If, within one year after delivery to the original owner, and after prepaid return by the original owner, this Avtech product is found to be defective, Avtech shall at its option repair or replace said defective item. This warranty does not apply to units which have been disassembled, modified or subjected to conditions exceeding the applicable specifications or ratings. This warranty is the extent of the obligation or liability assumed by Avtech with respect to this product and no other warranty or guarantee is either expressed or implied.

AVTECH ELECTROSYSTEMS LTD.

NANOSECOND WAVEFORM ELECTRONICS
ENGINEERING . MANUFACTURING

BOX 5120 STN. "F"
OTTAWA, ONTARIO
CANADA K2C 3H4
(613) 226-5772
TELEX 053-4591

P.O. BOX 265
OGDENSBURG
NEW YORK
13669
(315) 472-5270

Fig. 1

PULSE GENERATOR TEST ARRANGEMENT

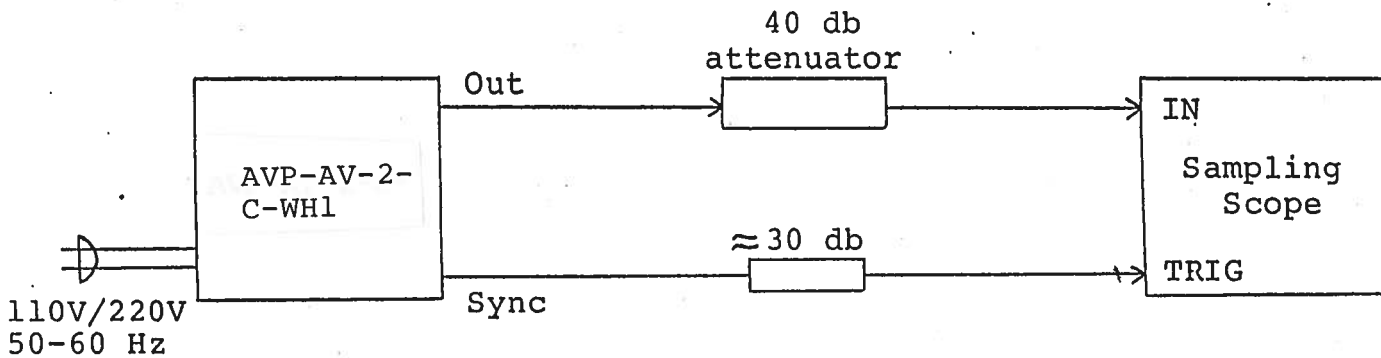

Notes:

- 1) The bandwidth capability of components and instruments used to display the pulse generator output signal (attenuators, cables, connectors, etc.) should exceed ten gigahertz.
- 2) The use of 40 db attenuator at the sampling scope vertical input channel will insure a peak input signal to the sampling scope of less than one volt.
- 3) The sync output channel provides TTL level signals. To avoid overdriving the TRIG input channel of some sampling scopes, a 30 db attenuator should be placed at the input to the sampling scope trigger channel.
- 4) The AVP-AV-2-C-WH1 contains two independent pulse generators which cover the output PW range of 0.2 to 3.0 nsec (A) and 3.0 nsec to 50 nsec (B). Separate PW and AMP controls are provided for the A and B channels. A and B share a common internal clock.

- 5) To obtain a stable output display the PRF controls on the front panel should be set mid-range while the PRF range switch may be in either range. The front panel TRIG toggle switch should be in the INT position. The front panel DELAY control and the scope triggering controls are then adjusted to obtain a stable output. The scope may then be used to set the desired PRF by rotating the PRF and PRF FINE controls and by means of the PRF range switch.
- 6) The output pulse width for A and B channels is controlled by means of the front panel one turn PW controls. The controls should initially be set maximum clockwise and the pulse width adjusted using an oscilloscope.
- 7) The output pulse amplitude for A and B channels is controlled by means of the front panel one turn AMP controls. The pulse width may change by several nanoseconds as the output amplitude is reduced from maximum to minimum. Therefore it is convenient to first set the desired amplitude and then set the desired pulse width. Rotation of the PW pot causes the position of the falling edge of the pulse to change.
- 8) Some properties of the output pulse may change as a function of the amplitude pot setting. For some demanding applications, it may be desirable to use a combination of external attenuators and the amplitude pot to achieve the desired output amplitude.
- 9) An external clock may be used to control the output PRF of the AVP unit by setting the front panel TRIG toggle switch in the EXT position and applying a 0.2 usec (approx) TTL level pulse to the SYNC BNC connector input. For operation in this mode, the scope time base must also be triggered by the external clock rather than from the SYNC output.
- 10) For units with the dual output polarity option (-PN) a positive output pulse is obtained at the OUT P SMA connector. To obtain a negative output pulse, the OUT P port is connected to the IN N port via a short length of miniature 50 ohm coaxial cable. A negative output pulse is then obtained at the OUT N port.

Fig. 2

FRONT PANEL CONTROLS

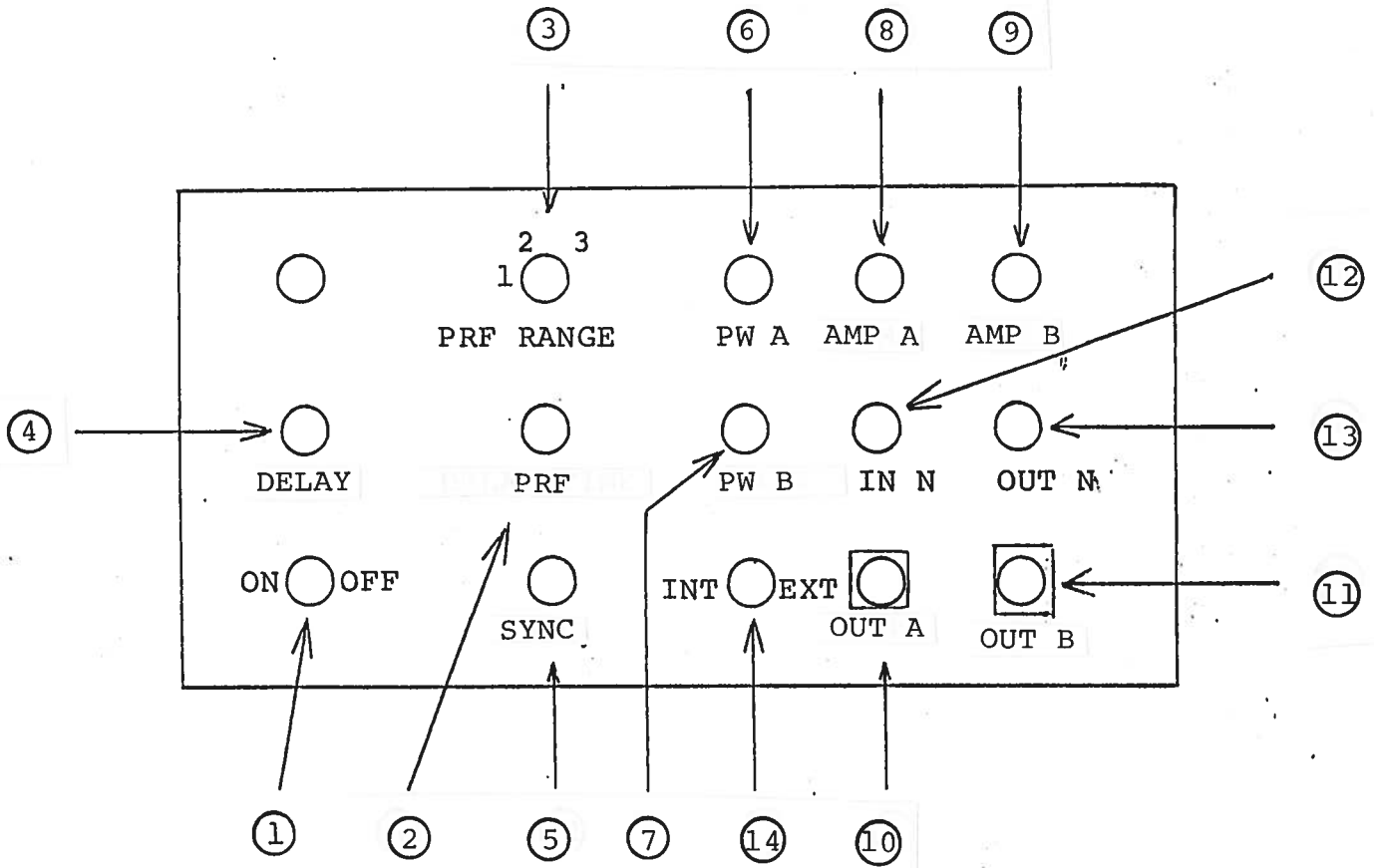

- ① ON-OFF Switch. Applies basic prime power to all stages.
- ② PRF Control. The PRF RANGE and PRF controls determine
- ③ output PRF as follows:

	PRF MIN	PRF MAX
Range 1	50 Hz	500 Hz
Range 2	500 Hz	5 KHz
Range 3	5 KHz	50 KHz

- ④ DELAY Control. Controls the relative delay between the reference output pulse provided at the SYNC output ⑤ and the main output ⑩ and ⑪. This delay is variable over the range of 0 to at least 500 nsec.
- ⑤ SYNC Output. This output precedes the main output ⑩ and ⑪ and is used to trigger the sampling scope time base. The output is a TTL level 100 nsec (approx) pulse capable of driving a fifty ohm load.
- ⑥ PW A and PW B Controls. A one turn control which varies the
⑦ output pulse width.
- ⑧ AMP A and AMP B Controls. A one turn control which varies the
⑨ output pulse amplitude.
- ⑩ OUT A and OUT B. Provide A output and B outputs to 50 ohm loads.
⑪
- ⑫ IN N, OUT N. For dual polarity option units connect OUT P to
⑬ IN N port to obtain negative output pulse at OUT N port.
- ⑭ EXT-INT Control. With this toggle switch in the INT position, the PRF of the AVP unit is controlled via an internal clock which in turn is controlled by the PRF controls. With the toggle switch in the EXT position, the AVP unit requires a 0.2 usec TTL level pulse applied at the SYNC input in order to trigger the output stages. In addition, in this mode, the scope time base must be triggered by the external trigger source.

Fig. 3

BACK PANEL CONTROLS

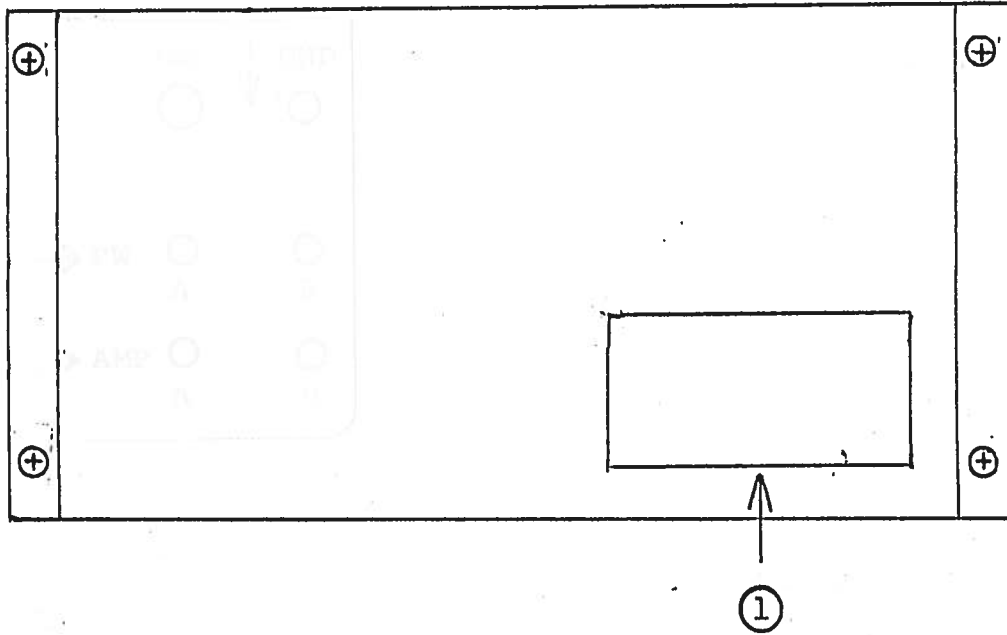

- ① FUSED CONNECTOR, VOLTAGE SELECTOR. The detachable power cord is connected at this point. In addition, the removable cord is adjusted to select the desired input operating voltage. The unit also contains the main power fuse.

Fig. 4

SYSTEM BLOCK DIAGRAM

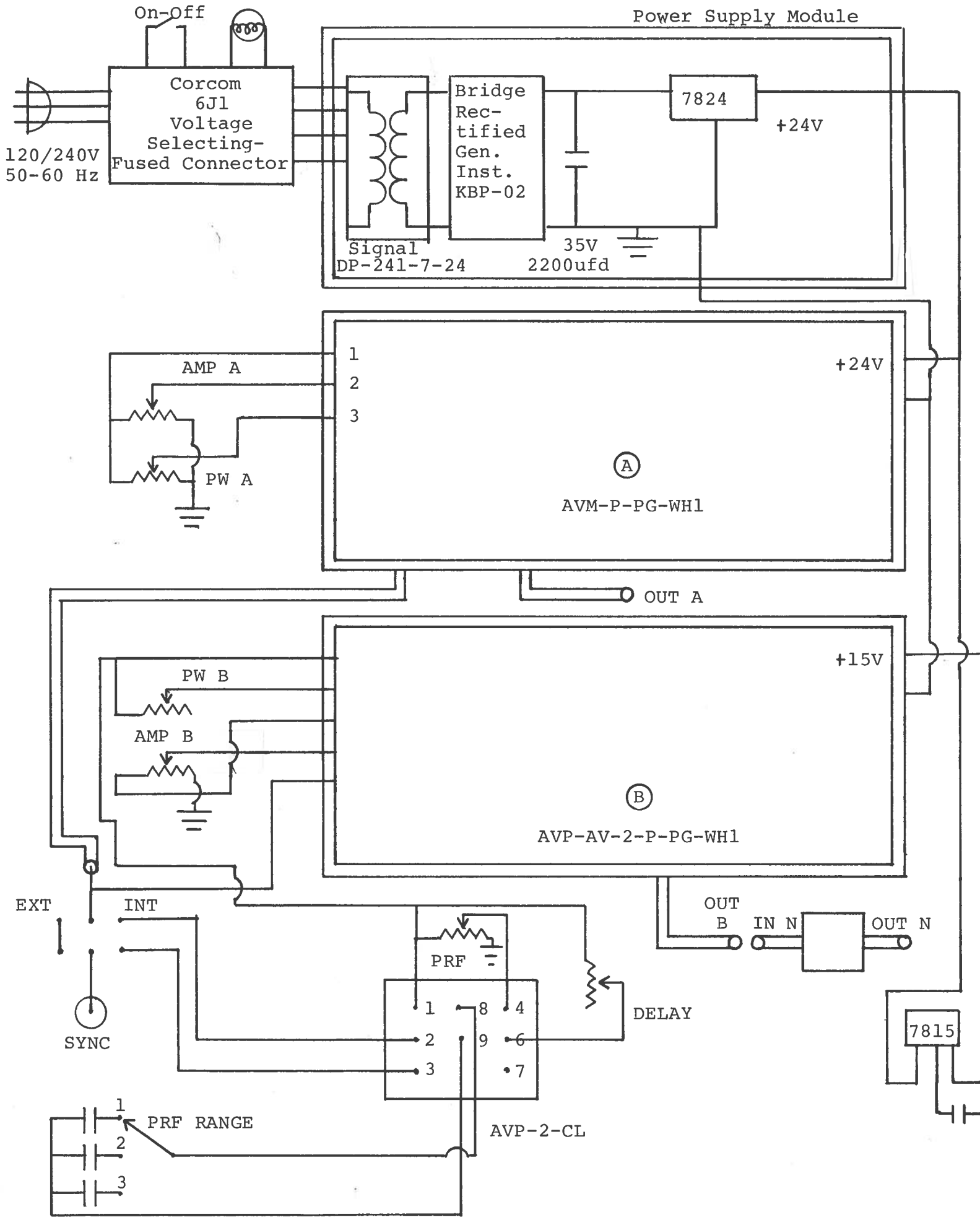

SYSTEM DESCRIPTION AND REPAIR PROCEDURE (-W UNITS)

The AVP-AV-2-C-WH1 consists of two pulse generator modules (AVP-AV-2-PG-WH1 and AVM-2-P-PG-WH1), a clock module (AVP-AV-2-CL) and a power supply board which supplies +24 volts (600 mA max) to the pulse generator modules. In the event that the unit malfunctions, remove the instrument cover by removing the 4 Phillips screws on the back panel of the unit. The top cover plate will then slide out. Measure the voltage at the +24 V pin of the PG module. If this voltage is substantially less than +24 volts, unsolder the line connecting the power supply and PG modules and connect 50 ohm 10 W load to the PS output. The voltage across this load should be about +24 V DC. If this voltage is substantially less than 24 volts the PS module is defective and should be repaired or replaced. If the voltage across the resistor is near 24 volts, then the PG modules should be replaced or repaired. The sealed PG modules must be returned to Avtech for repair (or replacement). The clock module provides a 0.1 usec TTL level trigger pulse at pin 2 to trigger the PG module and a 0.1 usec TTL level synch pulse at pin 3 to trigger the sampling scope display device. The output at pin 3 precedes the output at pin 2 by almost 0 to 500 nsec depending on the DELAY control setting. The clock module is powered by +5.8 V supplied by the PG module (from pin 5 to pin 1). With the INT-EXT switch in the EXT position, the clock module is disconnected from the PG module. The clock module is functioning properly if:

- a) 0.1 usec TTL level outputs are observed at pins 2 and 3.
- b) The PRF of the outputs can be varied over the range of 0.05 KHz to 50 KHz using the PRF and PRF RANGE controls.
- c) The relative delay between the pin 2 and 3 outputs can be varied by at least 500 nsec by the DELAY control.

The sealed clock module must be returned to Avtech for repair or replacement if the above conditions are not observed.

Schroff

08.16.84

-PN

albon

albon