



AVTECH ELECTROSYSTEMS LTD.

NANOSECOND WAVEFORM ELECTRONICS
SINCE 1975

P.O. BOX 265
OGDENSBURG, NY
U.S.A. 13669-0265
TEL: (315) 472-5270
FAX: (613) 226-2802

TEL: 1-800-265-6681
FAX: 1-800-561-1970

e-mail: info@avtechpulse.com
<http://www.avtechpulse.com/>

BOX 5120, LCD MERIVALE
OTTAWA, ONTARIO
CANADA K2C 3H4
TEL: (613) 226-5772
FAX: (613) 226-2802

INSTRUCTIONS

**MODEL AVP-3S
0 to 10V, 0.2 to 2 ns
PULSE GENERATOR
WITH 60 ps RISE TIME**

SERIAL NUMBER: _____

WARRANTY

Avtech Electrosystems Ltd. warrants products of its manufacture to be free from defects in material and workmanship under conditions of normal use. If, within one year after delivery to the original owner, and after prepaid return by the original owner, this Avtech product is found to be defective, Avtech shall at its option repair or replace said defective item. This warranty does not apply to units which have been disassembled, modified or subjected to conditions exceeding the applicable specifications or ratings. This warranty is the extent of the obligation assumed by Avtech with respect to this product and no other warranty or guarantee is either expressed or implied.

TECHNICAL SUPPORT

Phone: 613-226-5772 or 1-800-265-6681

Fax: 613-226-2802 or 1-800-561-1970

E-mail: info@avtechpulse.com

World Wide Web: <http://www.avtechpulse.com>

TABLE OF CONTENTS

WARRANTY.....2

TECHNICAL SUPPORT.....2

TABLE OF CONTENTS.....3

INTRODUCTION.....4

AVAILABLE OPTIONS.....4

SPECIFICATIONS.....5

EUROPEAN REGULATORY NOTES.....6

EC DECLARATION OF CONFORMITY.....6

DIRECTIVE 2002/95/EC (RoHS).....6

BASIC TEST ARRANGEMENT.....7

GENERAL OPERATING NOTES.....7

PERFORMANCE CHECK SHEET.....9

Manual Reference: T:\instructword\avp\AVP-3S,ed1.odt.
Last modified December 7, 2005.
Copyright © 2005 Avtech Electrosystems Ltd, All Rights Reserved.

INTRODUCTION

The AVP-3S is a high performance DC-powered module capable of generating up to 10V into 50Ω loads at repetition rates up to 1 MHz. The rise time is less than 60 ps, and the fall time is less than 100 ps. The pulse width is variable from 0.2 to 2 ns.

Instruments with the "-P" model suffix can generate 0 to +10V, whereas instruments with the "-N" model suffix can generate 0 to -10V.

The AVP-3S-C must be triggered by an external TTL pulse (> 50 ns) applied to the "IN" connector.

The output is designed to drive 50Ω loads. (A 50Ω load is required for proper operation.) The output is AC-coupled.

This instrument is intended for use in research and development laboratories.

AVAILABLE OPTIONS

The AVP-3S-C is available with several options:

-EA Option: the output amplitude can be controlled by an externally generated 0 to +10V analog control voltage.

-ECL Option: the input trigger levels are ECL, rather than TTL.

-EW Option: the output pulse width can be controlled by an externally generated 0 to +10V analog control voltage.

-M Option: a monitor output is provided.

-OS Option: an externally generated DC offset can be added to the output.

SPECIFICATIONS

Model:	AVP-3S
Amplitude ^{1,2} : (50 Ohm load)	0 to 10 Volts
Pulse width ¹ : (FWHM)	0.2 - 2.0 ns
PRF:	0 Hz to 1 MHz
Rise time (20%-80%):	≤ 60 ps
Fall time (80%-20%):	≤ 100 ps
Polarity:	Specify -P or -N
Propagation delay:	≤ 70 ns
Jitter, Ext trig in to pulse out:	±15 ps
DC offset or bias insertion:	Option available. Apply required DC offset or bias in the range of ± 50 Volts (250 mA max) to back panel solder terminal. See note 3.
Trigger required:	+5 Volt, 50 ns to 500 ns (TTL). ECL trigger option available. See note 5.
Monitor output option ⁴ :	Provides a 20 dB (x10) attenuated coincident replica of main output
Connectors: OUT, MONITOR ⁴ : TRIG: DC POWER:	SMA SMA solder terminals
Power requirement:	+15 Volt, 200 mA
Dimensions (H x W x D):	43 mm x 66 mm x 107 mm (1.7" x 2.6" x 4.2")
Chassis material:	Cast aluminum, blue enamel
Mounting, Temperature range:	Any, +5°C to +40°C

- 1) For analog electronic control (0 to +10V) of amplitude or pulse width suffix model number with -EA or -EW. Electronic control units also include standard front-panel controls.
- 2) For operation at amplitudes of less than 20% of full-scale, best results will be obtained by setting the amplitude near full-scale and using external attenuators on the output.
- 3) For externally applied DC offset option suffix model number with -OS. The Avtech AVX-T bias tee can also be used to obtain DC offset..
- 4) For monitor option add suffix -M.
- 5) For ECL trigger option, add suffix -ECL.

EUROPEAN REGULATORY NOTES

EC DECLARATION OF CONFORMITY

We

Avtech Electrosystems Ltd.
P.O. Box 5120, LCD Merivale
Ottawa, Ontario
Canada K2C 3H4

declare that this pulse generator meets the intent of Directive 89/336/EEC for Electromagnetic Compatibility. Compliance pertains to the following specifications as listed in the official Journal of the European Communities:

EN 50081-1 Emission

EN 50082-1 Immunity

and that this pulse generator meets the intent of the Low Voltage Directive 72/23/EEC as amended by 93/68/EEC. Compliance pertains to the following specifications as listed in the official Journal of the European Communities:

EN 61010-1:2001 Safety requirements for electrical equipment for measurement, control, and laboratory use



DIRECTIVE 2002/95/EC (RoHS)

This instrument is exempt from Directive 2002/95/EC of the European Parliament and of the Council of 27 January 2003 on the Restriction of the use of certain Hazardous Substances (RoHS) in electrical and electronic equipment. Specifically, Avtech instruments are considered "Monitoring and control instruments" (Category 9) as defined in Annex 1A of Directive 2002/96/EC. The Directive 2002/95/EC only applies to Directive 2002/96/EC categories 1-7 and 10, as stated in the "Article 2 - Scope" section of Directive 2002/95/EC.

BASIC TEST ARRANGEMENT

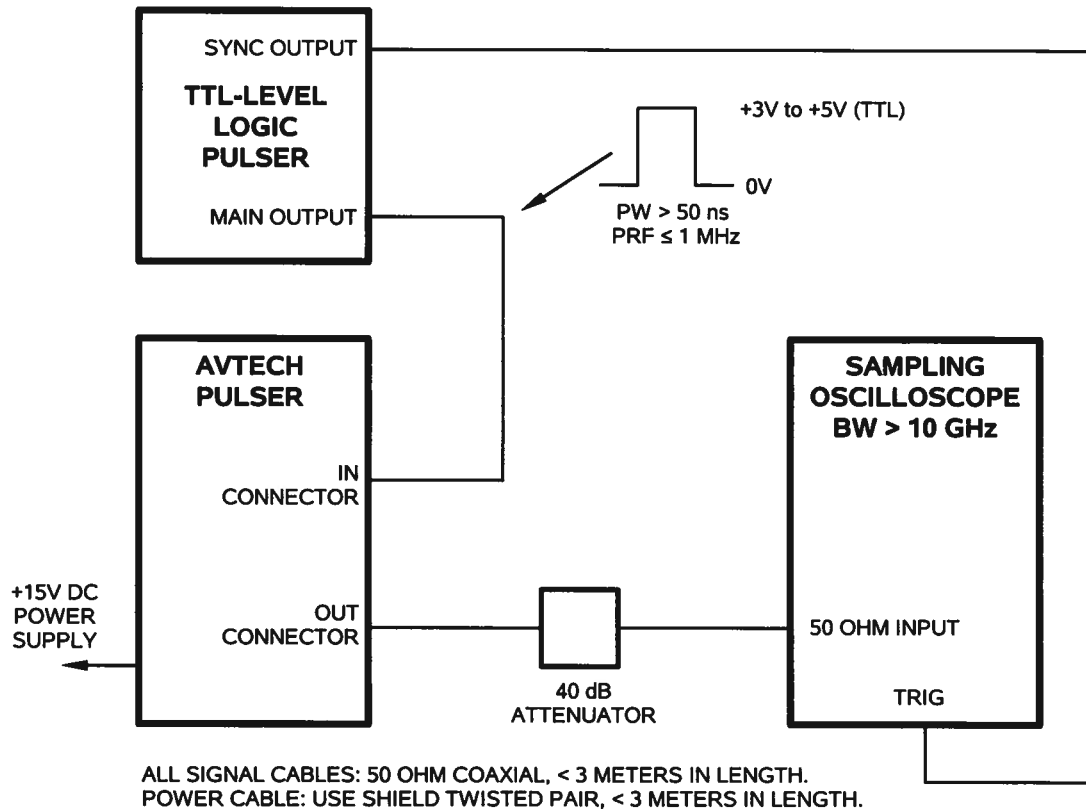

GENERAL OPERATING NOTES

- 1) The bandwidth capability of components and instruments used to display the pulse generator output signal (attenuators, cables, connectors, etc.) should exceed 10 GHz.
- 2) The use of 40 dB attenuator on the output will insure a peak input signal to the sampling scope of less than one volt.
- 3) In general, the source pulse generator trigger delay control should be set in the 0.1 to 1.0 μ s range, for proper positioning of the output pulse on the sampling oscilloscope display.
- 4) **WARNING:** The module may fail if triggered at a PRF greater than 1 MHz.
- 5) The output pulse width is controlled by means of the one turn potentiometer (PW). The pot should initially be set maximum clockwise and the pulse width adjusted using an oscilloscope.

- 6) The output pulse amplitude is controlled by means of the one turn potentiometer (AMP). The pulse width may change by several nanoseconds as the output amplitude is reduced from maximum to minimum. Therefore it is convenient to first set the desired amplitude and then set the desired pulse width. Rotation of the PW pot causes the position of the falling edge of the pulse to change.
- 7) Some properties of the output pulse may change as a function of the amplitude pot setting. For some demanding applications, it may be desirable to use a combination of external attenuators and the amplitude pot to achieve the desired output amplitude.
- 8) To DC offset the output pulse connect a DC power supply set to required DC offset value to the terminals marked "OS". The maximum attainable DC offset voltage is +50 volts. (Option).
- 9) The monitor output port (M) provides a coincident attenuated ($\div 10$) replica of the main output to a 50 ohm load. (Option).
- 10) For additional information:

Tel: 613-226-5772
Fax: 613-226-2802
Email: info@avtechpulse.com

Dec 7/05