



# AVTECH ELECTROSYSTEMS LTD.

NANOSECOND WAVEFORM ELECTRONICS  
SINCE 1975

P.O. BOX 265  
OGDENSBURG, NY  
U.S.A. 13669-0265

TEL: 888-670-8729 (USA & Canada) or +1-613-226-5772 (Intl)  
FAX: 800-561-1970 (USA & Canada) or +1-613-226-2802 (Intl)

info@avtechpulse.com - <http://www.avtechpulse.com/>

BOX 5120, LCD MERIVALE  
OTTAWA, ONTARIO  
CANADA K2C 3H4

## INSTRUCTIONS

MODEL AVP-AV-1-EA-EW-P-NTA-NTB  
0 to +10V, 0.2 to 4 ns  
PULSE GENERATOR  
WITH 100 ps RISE TIME

SERIAL NUMBER: \_\_\_\_\_

### WARRANTY

Avtech Electrosystems Ltd. warrants products of its manufacture to be free from defects in material and workmanship under conditions of normal use. If, within one year after delivery to the original owner, and after prepaid return by the original owner, this Avtech product is found to be defective, Avtech shall at its option repair or replace said defective item. This warranty does not apply to units which have been disassembled, modified or subjected to conditions exceeding the applicable specifications or ratings. This warranty is the extent of the obligation assumed by Avtech with respect to this product and no other warranty or guarantee is either expressed or implied.

### TECHNICAL SUPPORT

Phone: 888-670-8729 (USA & Canada) or +1-613-226-5772 (Intl)

Fax: 800-561-1970 (USA & Canada) or +1-613-226-2802 (Intl)

E-mail: [info@avtechpulse.com](mailto:info@avtechpulse.com)

World Wide Web: <http://www.avtechpulse.com>

## TABLE OF CONTENTS

<b>WARRANTY</b> .....	<b>2</b>
<b>TECHNICAL SUPPORT</b> .....	<b>2</b>
<b>TABLE OF CONTENTS</b> .....	<b>3</b>
<b>INTRODUCTION</b> .....	<b>4</b>
<b>SPECIFICATIONS</b> .....	<b>5</b>
<b>ORIGINAL QUOTATION</b> .....	<b>6</b>
<b>EUROPEAN REGULATORY NOTES</b> .....	<b>8</b>
<b>EC DECLARATION OF CONFORMITY</b> .....	<b>8</b>
<b>DIRECTIVE 2002/95/EC (RoHS)</b> .....	<b>8</b>
<b>DIRECTIVE 2002/96/EC (WEEE)</b> .....	<b>8</b>
<b>BASIC TEST ARRANGEMENT</b> .....	<b>10</b>
<b>CONTROLS - FRONT</b> .....	<b>10</b>
<b>CONTROLS - REAR</b> .....	<b>11</b>
<b>GENERAL OPERATING NOTES</b> .....	<b>12</b>
<b>PERFORMANCE CHECK SHEET</b> .....	<b>13</b>

Manual Reference: T:\instructword\avp\AVP-AV-1-EA-EW-P-NTA-NTB,ed1.odt.  
 Last modified September 20, 2007.  
 Copyright © 2007 Avtech Electrosystems Ltd, All Rights Reserved.

## INTRODUCTION

The AVP-AV-1-EA-EW-P-NTA-NTB is a high performance DC-powered module capable of generating up to 10V into 50 $\Omega$  loads at repetition rates up to 1 MHz. The rise time is less than 100 ps, and the fall time is less than 200 ps. The pulse width is variable from 0.2 to 4 ns.

The AVP-AV-1-EA-EW-P-NTA-NTB amplitude is controlled by a DC control voltage in the range of 0 to +10V applied to a solder terminal. Zero input corresponds to zero output, and +10V corresponds to maximum output amplitude (10V).

The AVP-AV-1-EA-EW-P-NTA-NTB pulse width is controlled by a DC control voltage in the range of 0 to +10V applied to a solder terminal. Zero input corresponds to < 0.2 ns pulse width, and +10V corresponds to maximum pulse width (> 4 ns).

The amplitude and pulse width controls may interact with each other and may also show a frequency dependence. Settings should be confirmed by measurement.

The AVP-AV-1-EA-EW-P-NTA-NTB is designed to be triggered by a +1V pulse, with width > 5 ns, applied to the "IN" connector.

The output is designed to drive 50 $\Omega$  loads. (A 50 $\Omega$  load is required for proper operation.) The output is AC-coupled.

This instrument is intended for use in research and development laboratories.

## SPECIFICATIONS

Model:	AVP-AV-1-EA-EW-P-NTA-NTB
Amplitude <sup>1,2</sup> : (50 Ohm load)	0 to +10 Volts
Pulse width <sup>1</sup> : (FWHM)	0.2 to 4 ns
PRF:	0 Hz to 1 MHz
Rise time (20%-80%):	≤ 100 ps
Fall time (80%-20%):	≤ 200 ps
Propagation delay:	≤ 250 ns
Jitter, Ext trig in to pulse out:	±15 ps
Trigger required:	+1 Volt, > 5 ns. 50 Ohm input impedance.
Sync output:	Provides a 50ns-wide TTL-level SYNC OUT pulse (to loads of 50 Ohms or higher). The SYNC OUT pulse precedes main output by approximately 30 ns.
Connectors: OUT, TRIG, SYNC: DC POWER: Amplitude, Pulse Width Controls:	SMA solder terminals solder terminals
Power requirement:	+15 Volt, 400 mA
Dimensions (H x W x D):	1.7" x 3.0" x 6.0"
Chassis material:	Cast aluminum, blue enamel
Mounting, Temperature range:	Any, +5°C to +40°C

- 1) For analog electronic control (0 to +10V) of amplitude or pulse width suffix model number with -EA or -EW. Electronic control units also include standard front-panel controls.
- 2) For operation at amplitudes of less than 20% of full-scale, best results will be obtained by setting the amplitude near full-scale and using external attenuators on the output.

ORIGINAL QUOTATION

Date: Wed, 29 Aug 2007 15:44:02 -0400  
From: Avtech Sales  
Subject: Re: Pulse generator requirement:

xxxxxx,

Following your recent inquiry, I am pleased to quote as follows:

Quote number: 13949

Model number: AVP-AV-1-EW-P-NTA-NTB

Description: Ultra High Speed Pulse Generator

Polarity: positive

-NTA option: The required trigger signal is a +1 Volt pulse, with a pulse width of 5 ns or higher, instead of the standard TTL levels. The input impedance of the trigger input is 50 Ohms.

-NTB option: Provides a 50ns-wide TTL-level SYNC OUT pulse (to loads of 50 Ohms or higher). The SYNC OUT pulse precedes main output by approximately 30 ns.

Pricing, manuals, datasheets: <http://www.avtechpulse.com/speed/avp-av-1>

PDF datasheet:

[http://www.avtechpulse.com/catalog/page024\\_cat11\\_avp\\_rev13.pdf](http://www.avtechpulse.com/catalog/page024_cat11_avp_rev13.pdf)

Price: \$xxxxxx US each, FOB destination.

Note: The basic price for the Model AVP-AV-1-EW-P is \$xxxxxx US. The -NTA option and the -NTB option are an additional \$xxxxxx for each. If you order only one of the options (either the -NTA or -NTB) then the price is \$xxxxxx US.

Quote valid for: 8 weeks

Delivery for quantity of 1 (excluding export permit\* delays): 2 weeks

Delivery for quantity of 4 (excluding export permit\* delays): 4 weeks

\*Export Permit: These instruments are very high performance pulse generators, which are considered to be "Nuclear-Related Dual-Use Goods" under government regulations. As such, an "End Use Statement" must be completed when ordering. The necessary form is attached (in PDF format). We will use the information in the completed form to apply for an export license from the Canadian government, which will take 1 to 4 weeks to obtain. We cannot ship your order without the license. Please return the completed form to us by fax.

Note: For the 2 week rush delivery it is imperative that we receive your

End-Use Statement with the order so that we can apply for the Export Permit very promptly. We expect to be able to obtain the Export Permit within the two weeks but we cannot guarantee it.

Please call or email me if I can be of further assistance.

Thank you for your interest in our products!

Regards,

Mary Budarick  
Sales Manager

--- Avtech Electrosystems Ltd. ----- since 1975 ---

PO Box 265	ph: 888-670-8729 or 613-226-5772	Box 5120
Ogdensburg	fax: 800-561-1970 or 613-226-2802	LCD Merivale
New York		Ottawa, Ontario
USA 13669-0265	email: <a href="mailto:info@avtechpulse.com">info@avtechpulse.com</a>	Canada K2C 3H4
	<a href="http://www.avtechpulse.com/">http://www.avtechpulse.com/</a>	

Pulse Generators - Laser Diode Drivers - HV Amplifiers  
Monocycle Generators - Impulse Generators - Pulse Amplifiers  
Current Pulsers - Function Generators - Frequency Dividers - and more!

-----  
Attachment: EndUse Statement generic3.pdf

## EUROPEAN REGULATORY NOTES

### EC DECLARATION OF CONFORMITY

We           Avtech Electrosystems Ltd.  
              P.O. Box 5120, LCD Merivale  
              Ottawa, Ontario  
              Canada K2C 3H4

declare that this pulse generator meets the intent of Directive 89/336/EEC for Electromagnetic Compatibility. Compliance pertains to the following specifications as listed in the official Journal of the European Communities:

EN 50081-1 Emission

EN 50082-1 Immunity

and that this pulse generator meets the intent of the Low Voltage Directive 72/23/EEC as amended by 93/68/EEC. Compliance pertains to the following specifications as listed in the official Journal of the European Communities:

EN 61010-1:2001 Safety requirements for electrical equipment for measurement, control, and laboratory use



### DIRECTIVE 2002/95/EC (RoHS)

This instrument is exempt from Directive 2002/95/EC of the European Parliament and of the Council of 27 January 2003 on the Restriction of the use of certain Hazardous Substances (RoHS) in electrical and electronic equipment. Specifically, Avtech instruments are considered "Monitoring and control instruments" (Category 9) as defined in Annex 1A of Directive 2002/96/EC. The Directive 2002/95/EC only applies to Directive 2002/96/EC categories 1-7 and 10, as stated in the "Article 2 - Scope" section of Directive 2002/95/EC.

### DIRECTIVE 2002/96/EC (WEEE)

European customers who have purchased this equipment directly from Avtech will have completed a "WEEE Responsibility Agreement" form, accepting responsibility for



WEEE compliance (as mandated in Directive 2002/96/EC of the European Union and local laws) on behalf of the customer, as provided for under Article 9 of Directive 2002/96/EC.

Customers who have purchased Avtech equipment through local representatives should consult with the representative to determine who has responsibility for WEEE compliance. Normally, such responsibilities will lie with the representative, unless other arrangements (under Article 9) have been made.

Requirements for WEEE compliance may include registration of products with local governments, reporting of recycling activities to local governments, and financing of recycling activities.

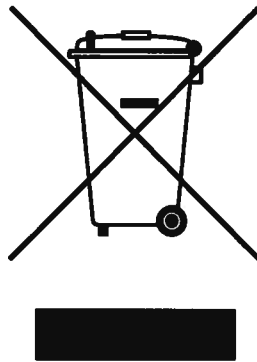

BASIC TEST ARRANGEMENT

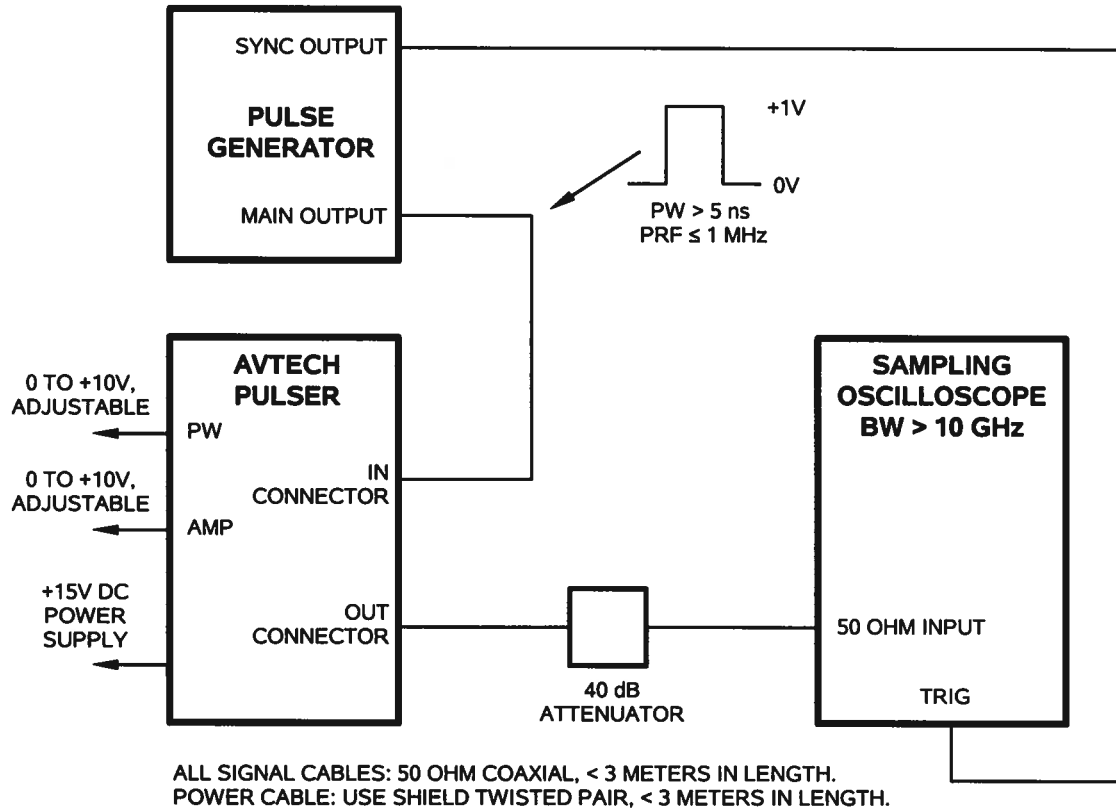

CONTROLS - FRONT

The location of the IN, OUT, and SYNC connectors and the amplitude and pulse width controls are shown in the photo below:

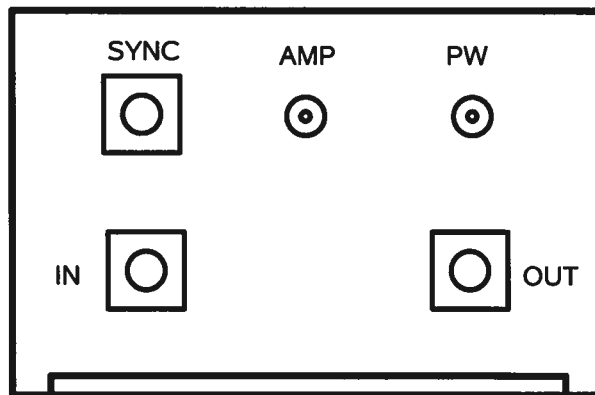

The function of each item is described below:

- **AMP.** The amplitude is controlled by a DC control voltage in the range of 0 to +10V applied to the “AMP” solder terminal. Zero input corresponds to zero output, and +10V corresponds to maximum output amplitude (10V).
- **PW.** The pulse width is controlled by a DC control voltage in the range of 0 to +10V applied to the “PW” solder terminal. Zero input corresponds to < 0.2 ns pulse width, and +10V corresponds to maximum pulse width (> 4 ns).
- **IN.** The AVP-AV-1-EA-EW-P-NTA-NTB is designed to be triggered by a +1V pulse, with width > 5 ns, applied to this connector. Do not exceed 1 MHz. The input impedance of this connector is 50 Ohms. For each input pulse, one output pulse will be generated.
- **SYNC.** This connector provides a 50ns-wide TTL-level SYNC OUT pulse to loads of 50 Ohms or higher. The SYNC OUT pulse precedes main output by approximately 30 ns.
- **OUT.** This is the main output. It must be terminated with 50 Ohms.

### CONTROLS - REAR

The location of the power terminals are shown in the photo below.

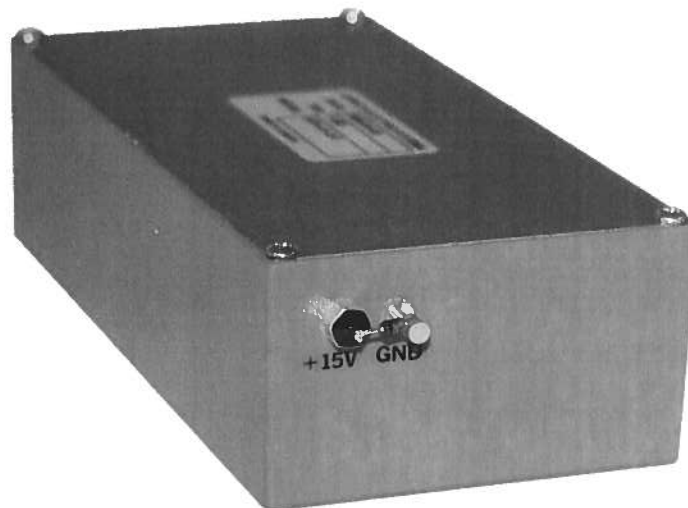

The +15V input terminal is protected with a 1N4746A Zener diode, which will fail as a short if an excessive positive voltage (> 18V), or a negative voltage, is applied to the terminal.

### GENERAL OPERATING NOTES

- 1) The bandwidth capability of components and instruments used to display the pulse generator output signal (attenuators, cables, connectors, etc.) should exceed 10 GHz.
- 2) The use of 40 dB attenuator on the output will ensure a peak input signal to the sampling scope of less than 1 Volt.
- 3) WARNING: The module may fail if triggered at a PRF greater than 1 MHz.
- 4) The amplitude, pulse width, and PRF parameters may interact to some extent. Some properties of the output pulse may change as a function of the amplitude setting. For some demanding applications, it may be desirable to use a combination of external attenuators and the amplitude control voltage to achieve the desired output amplitude.

Sept 20/07