



AVTECH ELECTROSYSTEMS LTD.

NANOSECOND WAVEFORM ELECTRONICS
SINCE 1975

P.O. BOX 265
OGDENSBURG, NY
U.S.A. 13669-0265

TEL: 888-670-8729 (USA & Canada) or +1-613-226-5772 (Intl)
FAX: 800-561-1970 (USA & Canada) or +1-613-226-2802 (Intl)

info@avtechpulse.com - <http://www.avtechpulse.com/>

BOX 5120, LCD MERIVALE
OTTAWA, ONTARIO
CANADA K2C 3H4

INSTRUCTIONS

MODEL AVP-AV-1-C

0 TO 10 VOLTS, 1 MHz

HIGH SPEED PULSE GENERATOR

WITH 100 ps RISE TIME, 200 ps FALL TIME

SERIAL NUMBER: _____

WARRANTY

Avtech Electrosystems Ltd. warrants products of its manufacture to be free from defects in material and workmanship under conditions of normal use. If, within one year after delivery to the original owner, and after prepaid return by the original owner, this Avtech product is found to be defective, Avtech shall at its option repair or replace said defective item. This warranty does not apply to units which have been disassembled, modified or subjected to conditions exceeding the applicable specifications or ratings. This warranty is the extent of the obligation assumed by Avtech with respect to this product and no other warranty or guarantee is either expressed or implied.

TECHNICAL SUPPORT

Phone: 888-670-8729 (USA & Canada) or +1-613-226-5772 (Intl)

Fax: 800-561-1970 (USA & Canada) or +1-613-226-2802 (Intl)

E-mail: info@avtechpulse.com

World Wide Web: <http://www.avtechpulse.com>

TABLE OF CONTENTS

WARRANTY.....	2
TECHNICAL SUPPORT.....	2
TABLE OF CONTENTS.....	3
INTRODUCTION.....	5
AVAILABLE OPTIONS.....	6
SPECIFICATIONS.....	7
EUROPEAN REGULATORY NOTES.....	8
EC DECLARATION OF CONFORMITY.....	8
DIRECTIVE 2002/95/EC (RoHS).....	8
DIRECTIVE 2002/96/EC (WEEE).....	8
INSTALLATION.....	10
VISUAL CHECK.....	10
POWER RATINGS.....	10
CONNECTION TO THE POWER SUPPLY.....	10
PROTECTION FROM ELECTRIC SHOCK.....	11
ENVIRONMENTAL CONDITIONS.....	11
FUSES.....	13
AC FUSE REPLACEMENT.....	13
DC FUSE REPLACEMENT.....	14
FUSE RATINGS.....	14
FRONT PANEL CONTROLS.....	15
REAR PANEL CONTROLS.....	17
GENERAL INFORMATION.....	19
BASIC TEST ARRANGEMENT.....	19
BASIC PULSE CONTROL.....	19
AMPLITUDE INTERACTION.....	20
POLARITY INVERSION.....	20
-DPP AND -DPN OPTIONS.....	21
MINIMIZING WAVEFORM DISTORTIONS.....	22
USE 50Ω TRANSMISSION LINES AND LOADS.....	22
USE LOW-INDUCTANCE LOADS.....	22
PREVENTING DAMAGE.....	22

MECHANICAL INFORMATION.....	23
TOP COVER REMOVAL.....	23
RACK MOUNTING.....	23
ELECTROMAGNETIC INTERFERENCE.....	23
MAINTENANCE.....	24
REGULAR MAINTENANCE.....	24
CLEANING.....	24
WIRING DIAGRAMS.....	25
WIRING OF AC POWER.....	25
PCB 158K - LOW VOLTAGE POWER SUPPLY, 1/3.....	26
PCB 158K - LOW VOLTAGE POWER SUPPLY, 2/3.....	27
PCB 158K - LOW VOLTAGE POWER SUPPLY, 3/3.....	28
PCB 168B - HIGH VOLTAGE DC POWER SUPPLY.....	29
PCB 126B - OSCILLATOR AND TRIGGER CIRCUIT.....	30
MAIN WIRING - POSITIVE UNITS.....	31
MAIN WIRING – UNITS WITH -DPP OR -DPN OPTIONS.....	32
PERFORMANCE CHECK SHEET.....	33

Manual Reference: T:\instructword\avp\AVP-AV-1-Cedi.odt.

Last modified February 1, 2007.

Copyright © 2007 Avtech Electrosystems Ltd, All Rights Reserved.

INTRODUCTION

The AVP-AV-1-C is a high performance instrument capable of generating up to 10V into 50 Ω loads at repetition rates up to 1 MHz. The rise time is less than 100 ps, and the fall time is less than 200 ps. The pulse width is variable from 0.2 to 4 ns.

Instruments with the "-P" model suffix can generate 0 to +10V, whereas instruments with the "-N" model suffix can generate 0 to -10V.

Instruments with the "-P-PN" suffix generate 0 to +10V at the main output, and are supplied with an inverting transformer that can be installed on the output to generate a negative signal.

Instruments with the "-N-PN" suffix generate 0 to -10V at the main output, and are supplied with an inverting transformer that can be installed on the output to generate a positive signal.

Instruments with the "-DPP" or "-DPN" options can generate pulse doublets with variable doublet spacing. The maximum output amplitude for these units is reduced by 30% compared to standard units (i.e., to 7V). The two pulses in the doublet can be delayed relative to each other over a -5 to +5 ns range.

The output is designed to drive 50 Ω loads. (A 50 Ω load is required for proper operation.) The output is AC-coupled.

This instrument is intended for use in research, development, test and calibration laboratories by qualified personnel.

AVAILABLE OPTIONS

The AVP-AV-1-C is available with several options:

-DPP Option: Double pulse waveform (both pulses in doublet are +). The two pulses in the doublet can be delayed relative to each other over a -5 to +5 ns range.

-DPN Option: Double pulse waveform (one pulse +, one pulse -). The two pulses in the doublet can be delayed relative to each other over a -5 to +5 ns range.

-EA Option: the output amplitude can be controlled by an externally generated 0 to +10V analog control voltage.

-ECL Option: the input trigger levels are ECL, rather than TTL.

-EO Option: the output offset can be controlled by an externally generated 0 to +10V analog control voltage.

-EW Option: the output pulse width can be controlled by an externally generated 0 to +10V analog control voltage.

-M Option: a monitor output is provided.

-OS Option: an externally generated DC offset can be added to the output.

-OT Option: an internally generated DC offset, controlled by a front-panel dial, can be added to the output.

SPECIFICATIONS

Model:	AVP-AV-1-C ¹
Amplitude ^{3,4,8} : (50 Ohm load)	0 - 10 Volts
Pulse width ³ : (FWHM)	0.2 - 4 ns
PRF: external trigger mode: internal trigger:	0 Hz to 1 MHz 100 Hz to 1 MHz
Rise time (20%-80%) ⁷ :	≤ 100 ps
Fall time (80%-20%) ⁷ :	≤ 200 ps
Polarity:	specify -P, -N, -P-PN, or -N-PN (see note 6)
Dual-Polarity Option Style:	One output, with inverting transformer accessory.
Two channel option:	Optional ⁷ .
Double pulse option:	Optional ⁸ .
Propagation delay: (Ext trig in to pulse out)	≤ 70 ns (Ext trig in to pulse out)
Jitter, Ext trig in to pulse out:	±15 ps
DC offset or bias insertion:	Optional ¹⁰ . Apply required DC offset or bias in the range of ± 50V (250 mA max) to back panel solder terminal.
Trigger required:	Ext trig mode: +5 Volt, 50 ns to 500 ns (TTL)
Sync delay:	Variable 0 to 500 ns (sync out to pulse out)
Sync output:	+3 Volts, 200 ns, will drive 50Ω
Monitor output option ¹¹ :	Provides a 20 dB (x10) attenuated coincident replica of main output
Connectors: OUT, MONITOR: TRIG / SYNC:	SMA BNC
Optional accessory kit:	Add the suffix "-AK1" to the model number to include the recommended accessory kit. Consists of three SMA, 18 GHz, 2 Watt attenuators (10, 20 & 30 dB) for use on the output, and two 50 Ohm, 1 GHz, 1 Watt feed-through terminators (one SMA, one BNC) for use on external trigger inputs.
Power requirement:	100 - 240 Volts, 50 - 60 Hz, Modules: +15 Volt, 200 mA
Dimensions (H x W x D):	100 mm x 430 mm x 375 mm (3.9" x 17" x 14.8")
Chassis material:	Anodized aluminum, with blue plastic trim
Mounting, Temperature range:	Any, +5°C to +40°C

- 1) -C suffix indicates stand-alone lab instrument with internal clock and line powering. No suffix indicates miniature module requiring DC power and external trigger. (See <http://www.avtechpulse.com/formats> for details of the four basic instrument formats).
- 2) -B suffix indicates IEEE-488.2 GPIB and RS-232 control of amplitude, pulse width, PRF and delay (See <http://www.avtechpulse.com/gpib>).
- 3) For analog electronic control (0 to +10V) of amplitude, pulse width or DC offset suffix model number with -EA or -EW or -EO. Electronic control units also include standard front-panel controls. -EW not available on -B units.
- 4) For operation at amplitudes of less than 20% of full-scale, best results will be obtained by setting the amplitude near full-scale and using external attenuators on the output.
- 5) For 20-500 ns pulse width, suffix model number with -W. Rise times increase to 150 ps for -W units. -W units have a propagation delay of 30 ns.
- 6) Indicate desired polarity by suffixing model number by -P or -N (i.e. positive or negative) or -P-PN or -N-PN for dual-polarity option where the suffix preceding -PN indicates the polarity at the mainframe output port.
- 7) For the two channel option, add the suffix -2CHPP for two positive outputs, the suffix -2CHNN for two negative outputs, or the suffix -2CHPN for the one positive output and one negative output.
- 8) For the double pulse option add the suffix -DPP for a unipolar output, and add the suffix -DPN for a bipolar output. Note that the maximum amplitude is reduced to 70% for DP option units. The two pulses in the double can be delayed relative to each other over a -5 to +5 ns range.
- 9) Add the suffix -TNT to the model number to specify the Telnet / Ethernet control option.
- 10) For externally applied DC offset option suffix model number with -OS. The Avtech AVX-T bias tee can also be used to obtain DC offset. For internally generated DC offset option (0 to ±5V) add suffix -OT or -EO to model number. (The -OT option is controlled by a front-panel dial, whereas the -EO option can be controlled by a front-panel dial or by an external 0 to +10V voltage). -OT, -EO not available on modules.
- 11) For monitor option add suffix -M.
- 12) For ECL trigger option, add suffix -ECL.

EUROPEAN REGULATORY NOTES

EC DECLARATION OF CONFORMITY

We Avtech Electrosystems Ltd.
 P.O. Box 5120, LCD Merivale
 Ottawa, Ontario
 Canada K2C 3H4

declare that this pulse generator meets the intent of Directive 89/336/EEC for Electromagnetic Compatibility. Compliance pertains to the following specifications as listed in the official Journal of the European Communities:

EN 50081-1 Emission

EN 50082-1 Immunity

and that this pulse generator meets the intent of the Low Voltage Directive 72/23/EEC as amended by 93/68/EEC. Compliance pertains to the following specifications as listed in the official Journal of the European Communities:

EN 61010-1:2001 Safety requirements for electrical equipment for measurement, control, and laboratory use



DIRECTIVE 2002/95/EC (RoHS)

This instrument is exempt from Directive 2002/95/EC of the European Parliament and of the Council of 27 January 2003 on the Restriction of the use of certain Hazardous Substances (RoHS) in electrical and electronic equipment. Specifically, Avtech instruments are considered "Monitoring and control instruments" (Category 9) as defined in Annex 1A of Directive 2002/96/EC. The Directive 2002/95/EC only applies to Directive 2002/96/EC categories 1-7 and 10, as stated in the "Article 2 - Scope" section of Directive 2002/95/EC.

DIRECTIVE 2002/96/EC (WEEE)

European customers who have purchased this equipment directly from Avtech will have completed a "WEEE Responsibility Agreement" form, accepting responsibility for

WEEE compliance (as mandated in Directive 2002/96/EC of the European Union and local laws) on behalf of the customer, as provided for under Article 9 of Directive 2002/96/EC.

Customers who have purchased Avtech equipment through local representatives should consult with the representative to determine who has responsibility for WEEE compliance. Normally, such responsibilities will lie with the representative, unless other arrangements (under Article 9) have been made.

Requirements for WEEE compliance may include registration of products with local governments, reporting of recycling activities to local governments, and financing of recycling activities.

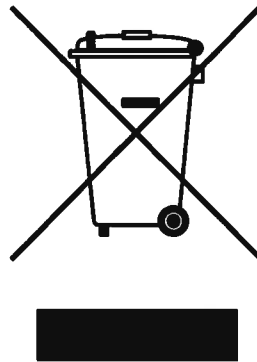

GENERAL INFORMATION

BASIC TEST ARRANGEMENT

The AVP-AV-1-C should be tested with a sampling oscilloscope with a bandwidth of at least 10 GHz to properly observe the high-speed waveform. (The cables and attenuators must also have a bandwidth of at least 10 GHz.) A typical test arrangement is shown below:

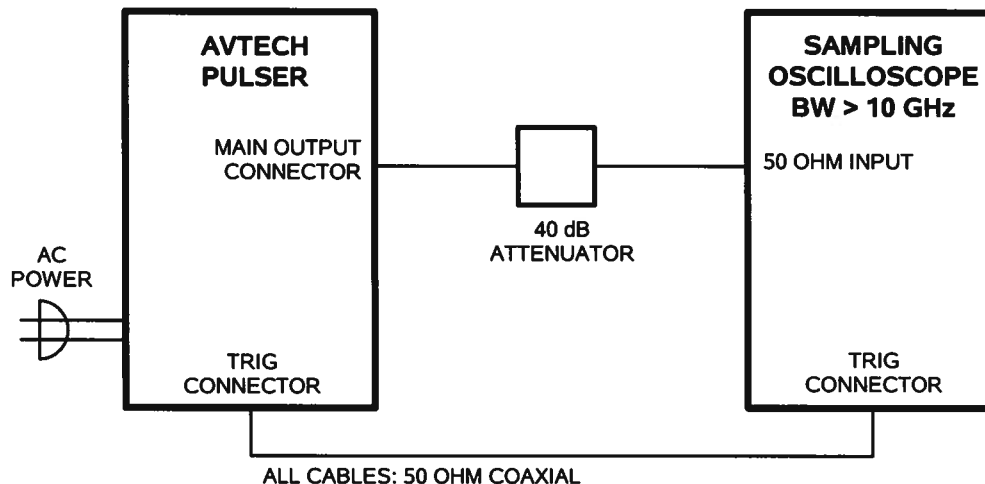

The attenuators are required to prevent damage to the sampling oscilloscope. A 40 dB attenuator with sufficient voltage rating should be used on the main output.

BASIC PULSE CONTROL

This instrument can be triggered by its own internal clock or by an external TTL trigger signal. When triggered internally, two mainframe output channels respond to the trigger: OUT and SYNC.

- OUT. This is the main output. The maximum output voltage is 10V.
- TRIG. The TRIG pulse is a fixed-width TTL-level reference pulse used to trigger oscilloscopes or other measurement systems.

The TRIG output precedes the main output. These pulses are illustrated below:

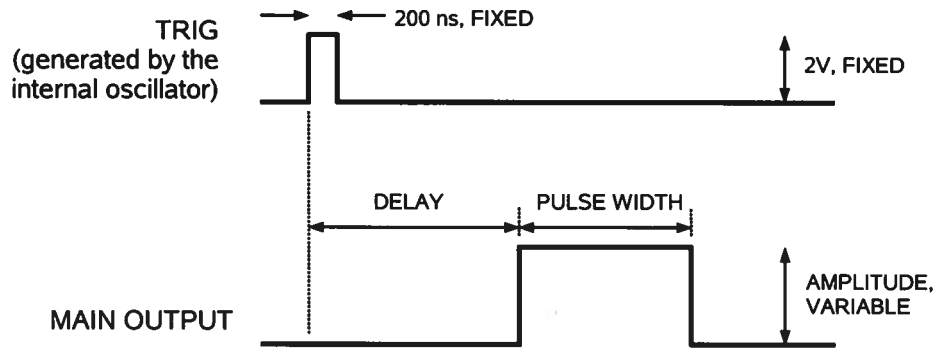

When triggered externally, the TRIG connector acts as an input. The delay controls do not function in this mode. This illustrated below:

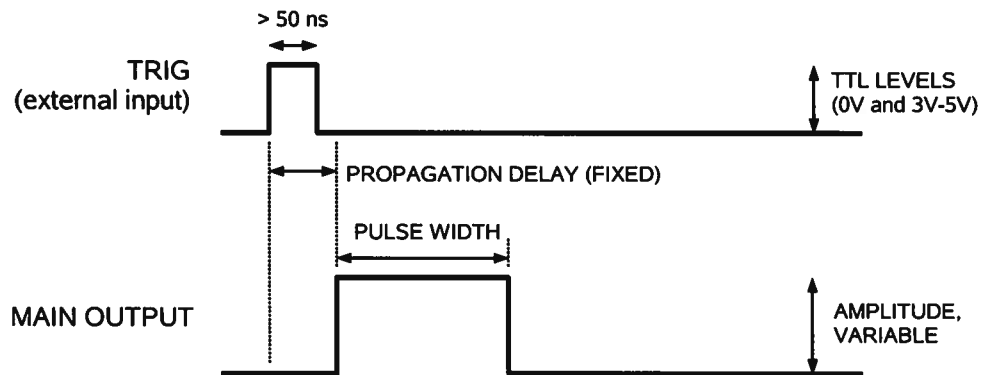

AMPLITUDE INTERACTION

Some properties of the output pulse may change as a function of the amplitude setting. For some demanding applications, it may be desirable to use a combination of external attenuators and the amplitude pot to achieve the desired output amplitude.

POLARITY INVERSION

Instruments with the "-P-PN" suffix generate 0 to +10V at the main output, and are supplied with an inverting transformer that can be installed on the mainframe output. A negative pulse is then obtained at the out port of the transformer module.

Instruments with the "-N-PN" suffix generate 0 to -10V at the main output, and are supplied with an inverting transformer that can be installed on the mainframe output. A positive pulse is then obtained at the out port of the transformer module.

When using the transformer with dual-polarity models with the "-OS" option, the external offset must be added to the DC terminal of the inverting transformer. Do not apply the offset to the rear-panel offset terminal on the mainframe (if present).

-DPP AND -DPN OPTIONS

Units with the -DPP or -DPN options can generate a pulse doublet in response to each trigger event. For internal triggering, the -DPP signals are related as shown below:

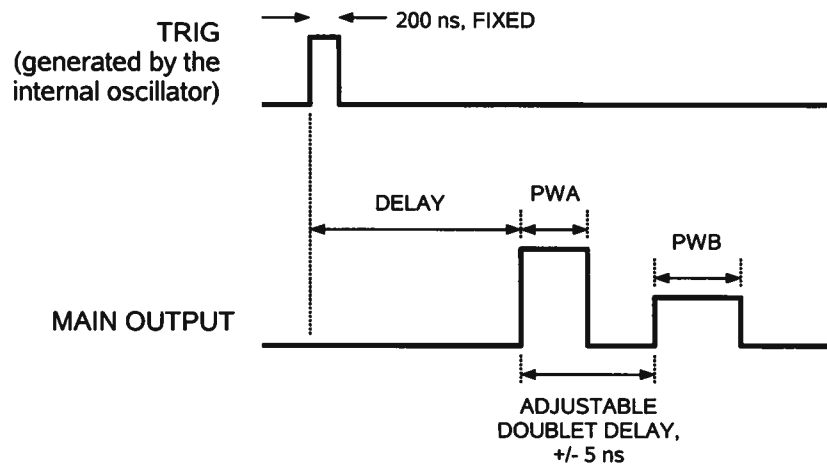

For the -DPN option, one of the pulses in the doublet is negative:

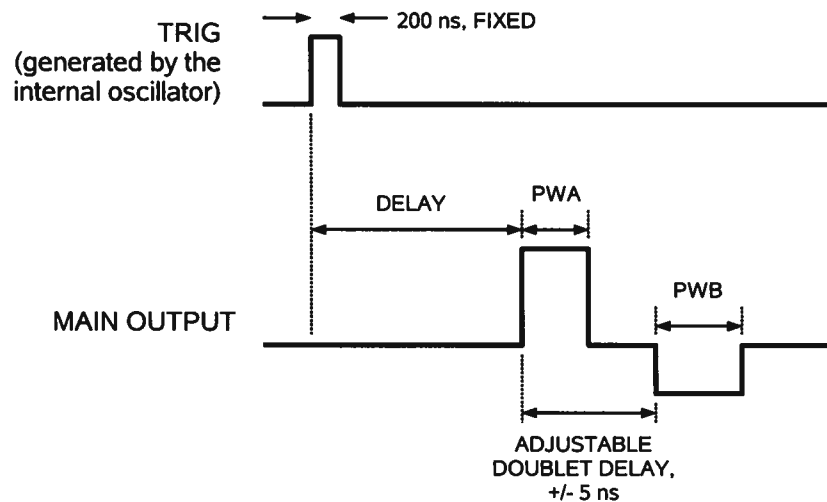

The "A" and "B" portions of the pulse doublet may be individually enabled or disabled.

MINIMIZING WAVEFORM DISTORTIONS

USE 50Ω TRANSMISSION LINES AND LOADS

Connect the load to the pulse generator with 50Ω transmission lines (e.g. RG-58 or RG-174 cable).

This instrument requires a 50Ω load for proper operation. It will not properly drive a high-impedance load. The output stage will be damaged if it is operated into an open circuit (or any other high impedance). Failures due to improper output loading are not covered by the warranty.

USE LOW-INDUCTANCE LOADS

Lenz's Law predicts that for an inductive voltage spike will be generated when the current through an inductance changes. Specifically, $V_{\text{SPIKE}} = L \times di_{\text{LOAD}}/dt$, where L is the inductance, i_{LOAD} is the load current change, and t is time. For this reason, it is important to keep any parasitic in the load low. This means keeping wiring short, and using low inductance components. In particular, wire-wound resistors should be avoided.

PREVENTING DAMAGE

The AVP-AV-1-C may fail if triggered at a PRF greater than 1 MHz.

This unit is designed to operate into a load impedance of 50 Ohms and the output stage will be damaged if it is operated into an open circuit (or any other high impedance). Failures due to improper output loading are not covered by the warranty.

The lifetime of the switching elements in the pulse generator module is proportional to the running time of the instrument. For this reason the prime power to the instrument should be turned off when the instrument is not in use.

MECHANICAL INFORMATION

TOP COVER REMOVAL

If necessary, the interior of the instrument may be accessed by removing the four Phillips screws on the top panel. With the four screws removed, the top cover may be slid back (and off).

 Always disconnect the power cord and allow the instrument to sit unpowered for 10 minutes before opening the instrument. This will allow any internal stored charge to discharge.

There are no user-adjustable internal circuits. For repairs other than fuse replacement, please contact Avtech (info@avtechpulse.com) to arrange for the instrument to be returned to the factory for repair. Service is to be performed solely by qualified service personnel.

 Caution: High voltages are present inside the instrument during normal operation. Do not operate the instrument with the cover removed.

RACK MOUNTING

A rack mounting kit is available. The -R5 rack mount kit may be installed after first removing the one Phillips screw on the side panel adjacent to the front handle.

ELECTROMAGNETIC INTERFERENCE

To prevent electromagnetic interference with other equipment, all used outputs should be connected to shielded loads using shielded coaxial cables. Unused outputs should be terminated with shielded coaxial terminators or with shielded coaxial dust caps, to prevent unintentional electromagnetic radiation. All cords and cables should be less than 3m in length.

MAINTENANCE

REGULAR MAINTENANCE

This instrument does not require any regular maintenance.

On occasion, one or more of the four rear-panel fuses may require replacement. All fuses can be accessed from the rear panel. See the “FUSES” section for details.

CLEANING

If desired, the interior of the instrument may be cleaned using compressed air to dislodge any accumulated dust. (See the “TOP COVER REMOVAL” section for instructions on accessing the interior.) No other cleaning is recommended.

PCB 158K - LOW VOLTAGE POWER SUPPLY, 1/3

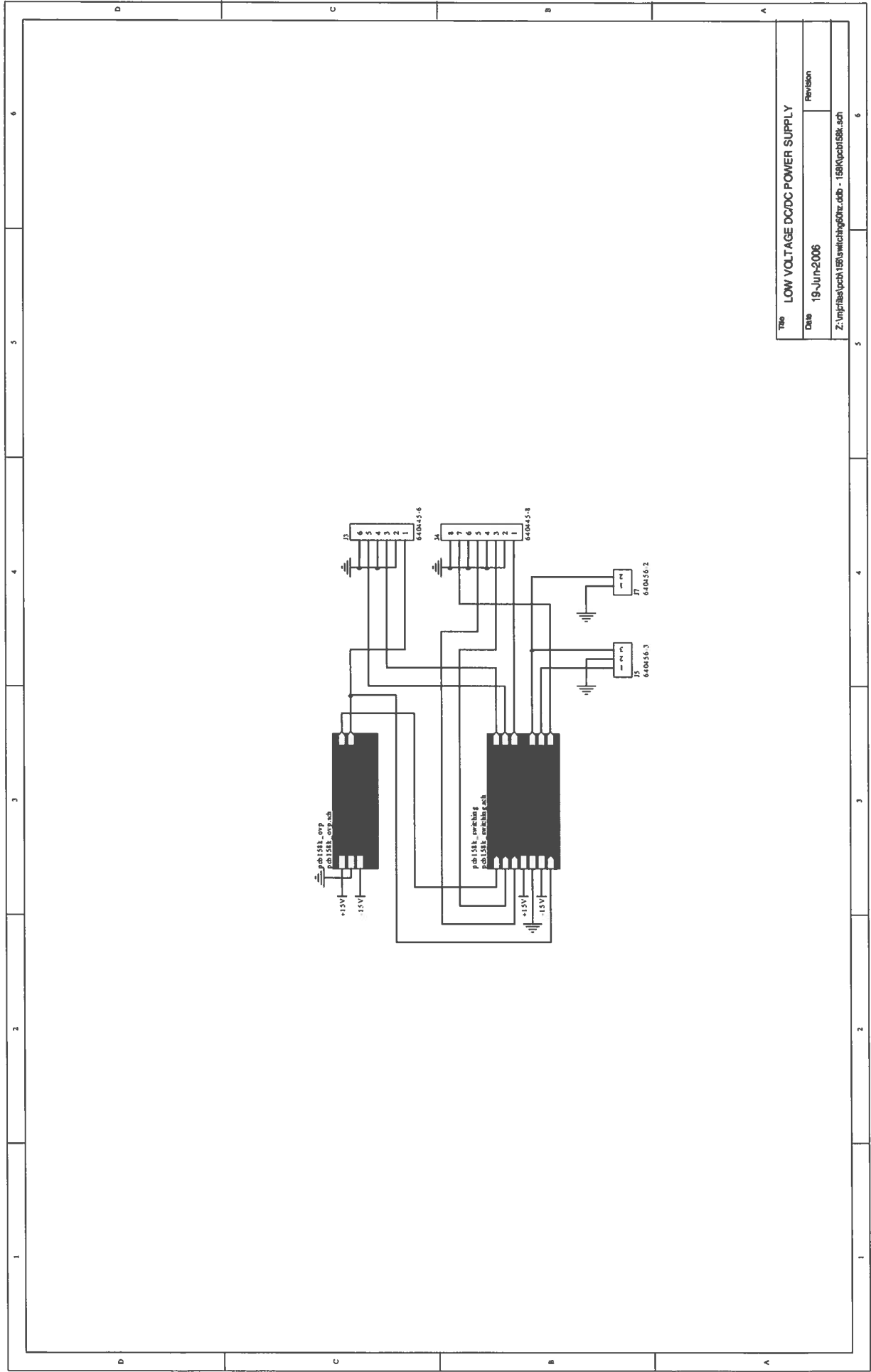

Title	LOW VOLTAGE DC/DC POWER SUPPLY
Date	19-Jun-2006
Revision	
Z:\mjrfiles\pcb158k\switching60hz.ddb - 158k\pcb158k.sch	

PCB 158K - LOW VOLTAGE POWER SUPPLY, 2/3

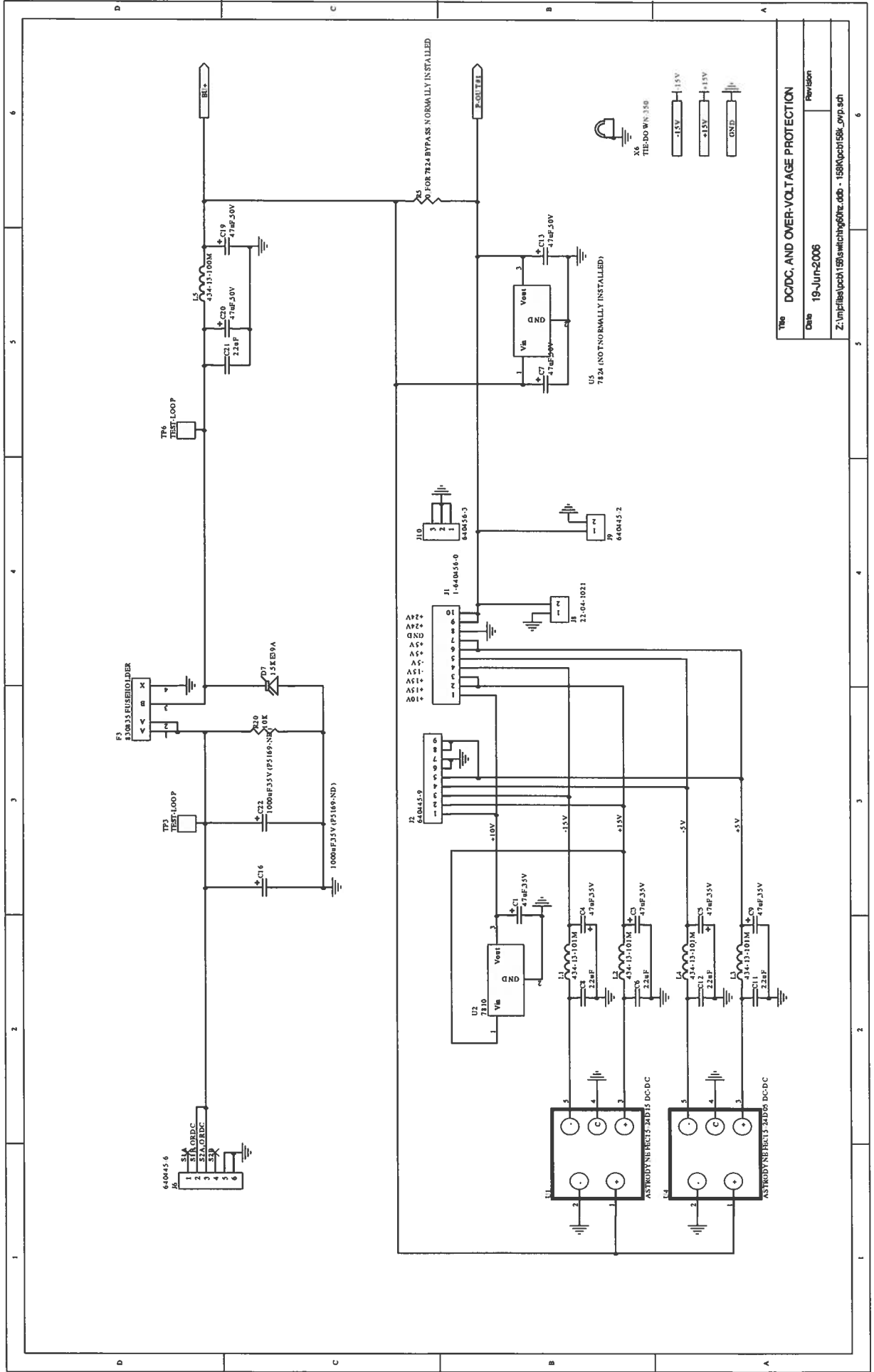

Title	DCDC, AND OVER-VOLTAGE PROTECTION
Date	19-Jun-2006
Revision	
Z:\mfrfiles\pcb158k\sch\cbg60hz.cdb - 158k\pcb158k_vrp.sch	

PCB 158K - LOW VOLTAGE POWER SUPPLY, 3/3

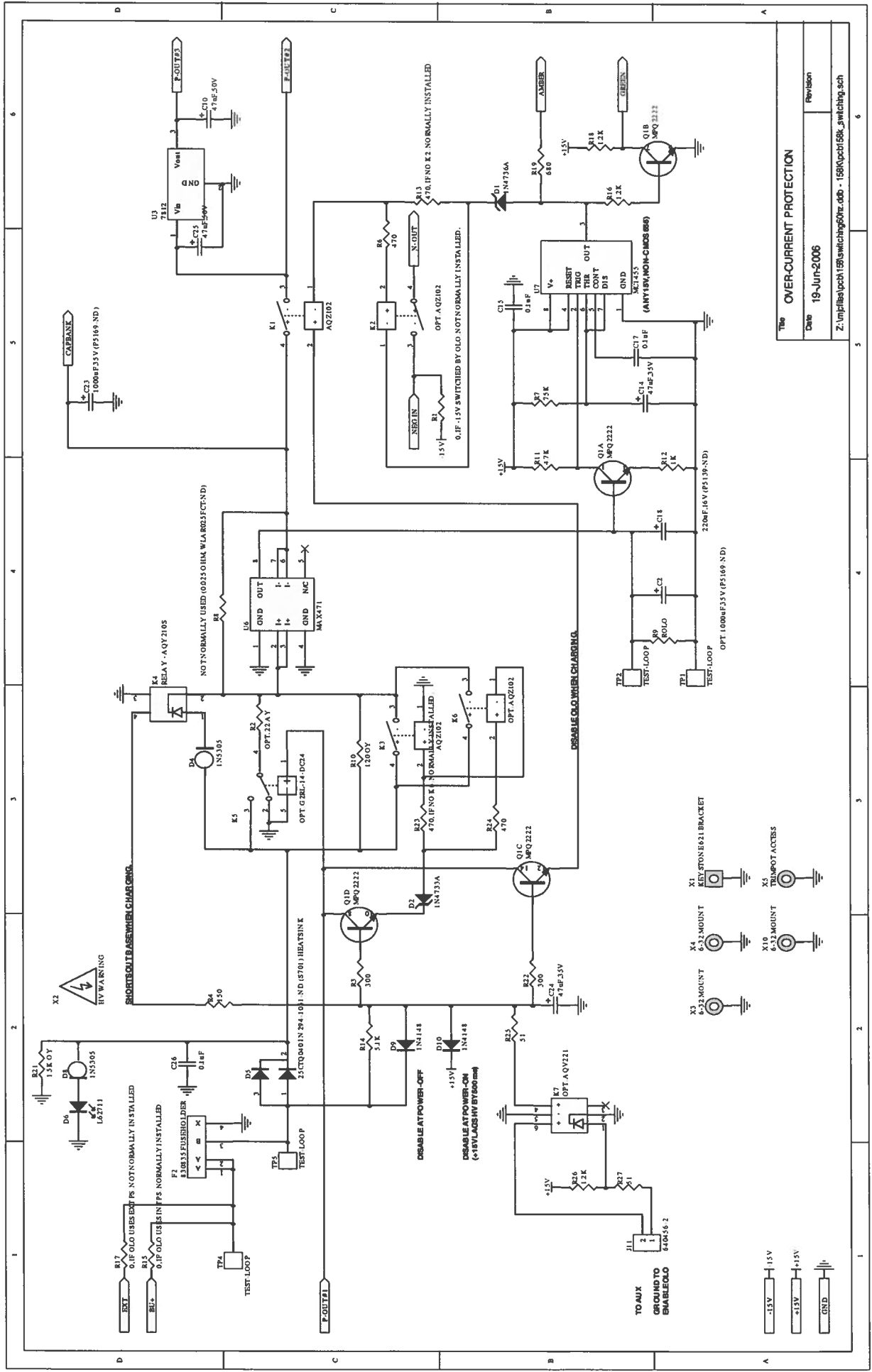

Rev	OVER-CURRENT PROTECTION
Date	19-Jun-2006
Revision	
Z:\mpj\lib\pcb158k\switching50tr.ddd - 158K\pcb158k_switching.sch	

PCB 168B - HIGH VOLTAGE DC POWER SUPPLY

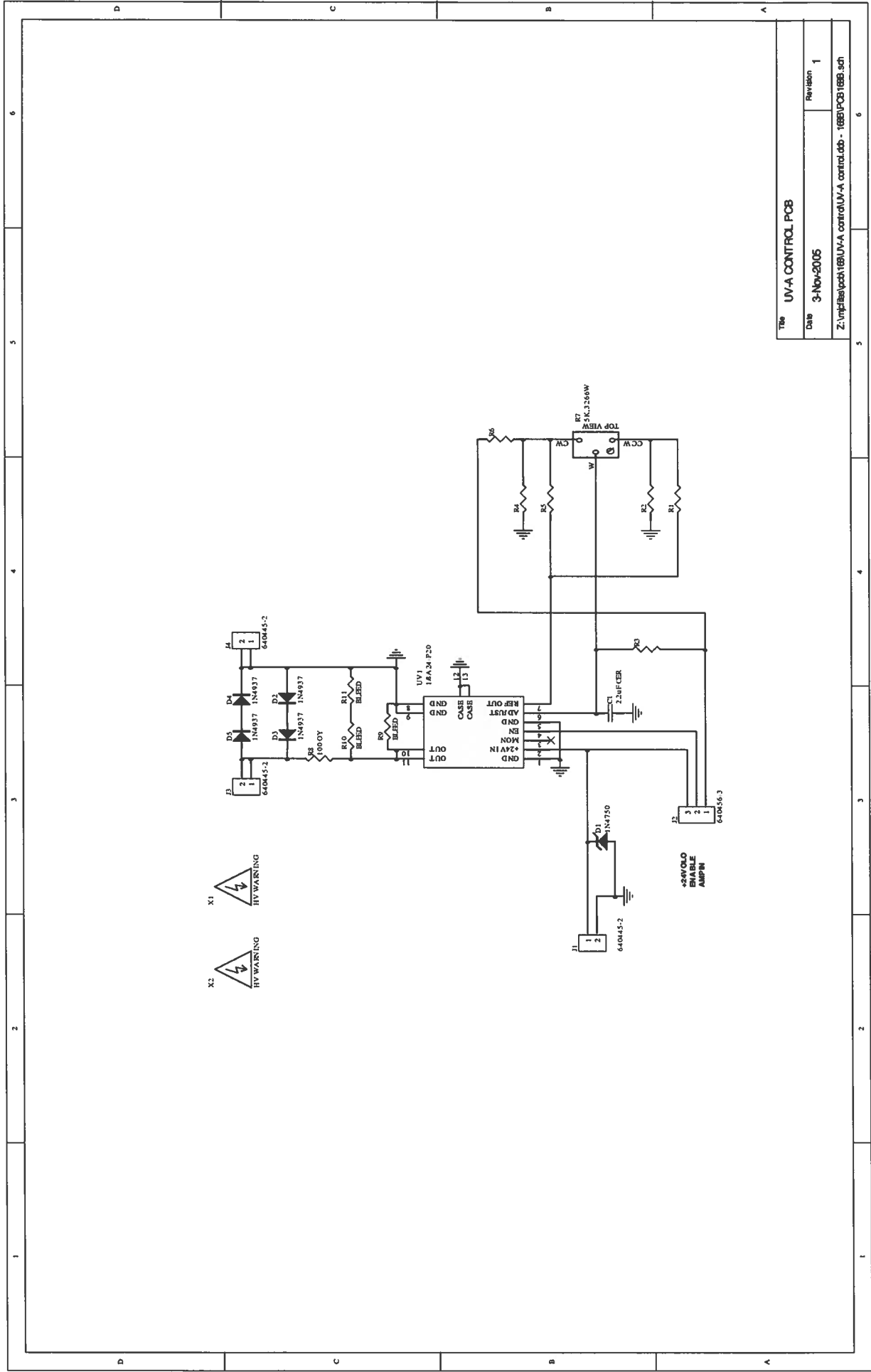

Title	UV-A CONTROL PCB
Date	3-Nov-2005
Revision	1
Z:\mfg\ba\pcb\168\UV-A control\UV-A control.dwg - 168B\PCB168B.sch	

MAIN WIRING - POSITIVE UNITS

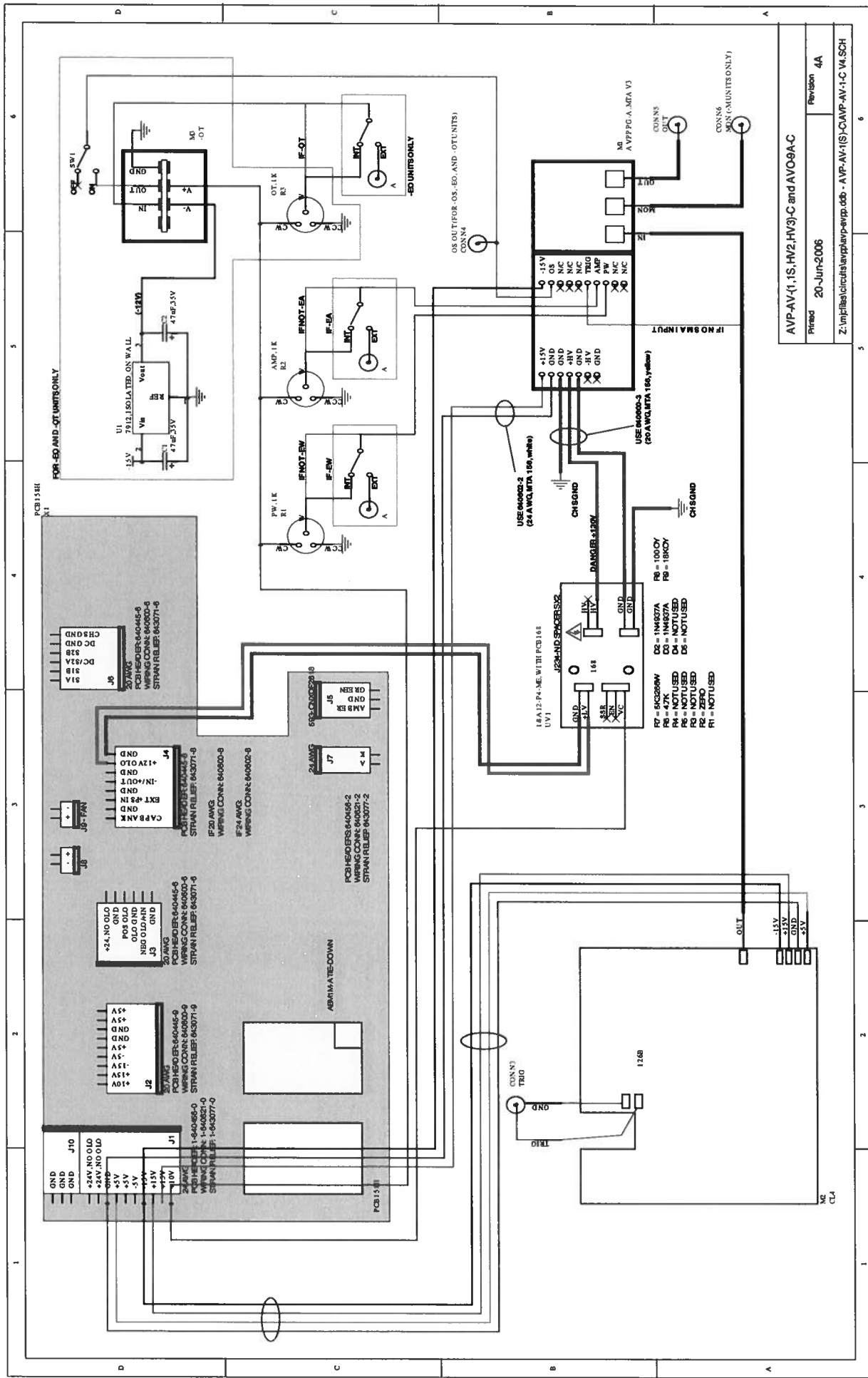

AVP-AV-1 (1S, HV2, HV3) C and AV09AC
Printed 20-Jun-2006
Revision 4A

Z:\mp\files\circuit\avp\avp-avpp.ddb - AVP-AV-1(S)-CAVP-AV-1-C V4.SCH

Feb 1/07