



AVTECH ELECTROSYSTEMS LTD.

NANOSECOND WAVEFORM ELECTRONICS
SINCE 1975

P.O. BOX 265
OGDENSBURG, NY
U.S.A. 13669-0265
TEL: (315) 472-5270
FAX: (613) 226-2802

TEL: 1-800-265-6681
FAX: 1-800-561-1970

e-mail: info@avtechpulse.com
<http://www.avtechpulse.com/>

BOX 5120, LCD MERIVALE
OTTAWA, ONTARIO
CANADA K2C 3H4
TEL: (613) 226-5772
FAX: (613) 226-2802

INSTRUCTIONS

MODEL AVP-AV-HV2-C

0 TO 20 VOLTS, 1 MHz

HIGH SPEED PULSE GENERATOR

WITH 100 ps RISE TIME, 200 ps FALL TIME

SERIAL NUMBER: _____

WARRANTY

Avtech Electrosystems Ltd. warrants products of its manufacture to be free from defects in material and workmanship under conditions of normal use. If, within one year after delivery to the original owner, and after prepaid return by the original owner, this Avtech product is found to be defective, Avtech shall at its option repair or replace said defective item. This warranty does not apply to units which have been disassembled, modified or subjected to conditions exceeding the applicable specifications or ratings. This warranty is the extent of the obligation assumed by Avtech with respect to this product and no other warranty or guarantee is either expressed or implied.

TECHNICAL SUPPORT

Phone: 613-226-5772 or 1-800-265-6681

Fax: 613-226-2802 or 1-800-561-1970

E-mail: info@avtechpulse.com

World Wide Web: <http://www.avtechpulse.com>

TABLE OF CONTENTS

WARRANTY.....	2
TECHNICAL SUPPORT.....	2
TABLE OF CONTENTS.....	3
INTRODUCTION.....	5
AVAILABLE OPTIONS.....	6
SPECIFICATIONS.....	7
EC DECLARATION OF CONFORMITY.....	8
INSTALLATION.....	9
VISUAL CHECK.....	9
POWER RATINGS.....	9
CONNECTION TO THE POWER SUPPLY.....	9
ENVIRONMENTAL CONDITIONS.....	9
FUSES.....	10
AC FUSE REPLACEMENT.....	10
DC FUSE REPLACEMENT.....	11
FUSE RATINGS.....	11
FRONT PANEL CONTROLS.....	12
REAR PANEL CONTROLS.....	14
GENERAL INFORMATION.....	16
BASIC TEST ARRANGEMENT.....	16
BASIC PULSE CONTROL.....	16
AMPLITUDE INTERACTION.....	17
POLARITY INVERSION.....	17
MINIMIZING WAVEFORM DISTORTIONS.....	18
USE 50Ω TRANSMISSION LINES AND LOADS.....	18
USE LOW-INDUCTANCE LOADS.....	18
PREVENTING DAMAGE.....	18
MECHANICAL INFORMATION.....	19
TOP COVER REMOVAL.....	19
ELECTROMAGNETIC INTERFERENCE.....	19
MAINTENANCE.....	19

REGULAR MAINTENANCE.....19
CLEANING.....19
PERFORMANCE CHECK SHEET.....20

Manual Reference: T:\instructword\avp\AVP-AV-HV2-C,edition2.sxw.
Last modified August 27, 2004.
Copyright © 2003 Avtech Electrosystems Ltd, All Rights Reserved.

INTRODUCTION

The AVP-AV-HV2-C is a high performance instrument capable of generating up to 20V into 50 Ω loads at repetition rates up to 1 MHz. The rise time is less than 100 ps, and the fall time is less than 200 ps. The pulse width is variable from 0.3 to 2 ns.

Instruments with the "-P" model suffix can generate 0 to +20V, whereas instruments with the "-N" model suffix can generate 0 to -20V.

Instruments with the "-P-PN" suffix generate 0 to +20V at the main output, and are supplied with an inverting transformer that can be installed on the output to generate a negative signal.

Instruments with the "-N-PN" suffix generate 0 to -20V at the main output, and are supplied with an inverting transformer that can be installed on the output to generate a positive signal.

The output is designed to drive 50 Ω loads. (A 50 Ω load is required for proper operation.) The output is AC-coupled.

This instrument is intended for use in research and development laboratories.

AVAILABLE OPTIONS

The AVP-AV-HV2-C is available with several options:

-EA Option: the output amplitude can be controlled by an externally generated 0 to +10V analog control voltage.

-ECL Option: the input trigger levels are ECL, rather than TTL.

-EO Option: the output offset can be controlled by an externally generated 0 to +10V analog control voltage.

-EW Option: the output pulse width can be controlled by an externally generated 0 to +10V analog control voltage.

-M Option: a monitor output is provided.

-OS Option: an externally generated DC offset can be added to the output.

-OT Option: an internally generated DC offset, controlled by a front-panel dial, can be added to the output.

SPECIFICATIONS

Model:	AVP-AV-HV2-C ¹
Amplitude ^{3,4,7} : (50 Ohm load)	0 to 20 Volts
Pulse width ³ :	0.3 - 2.0 ns
PRF: external trigger:	0 Hz to 1 MHz
internal trigger:	100 Hz to 1 MHz
Rise time (20%-80%) ⁷ :	≤ 100 ps
Fall time (80%-20%) ⁷ :	≤ 200 ps
Polarity:	specify -P, -N, -P-PN, or -N-PN (see note 6)
Dual Polarity Option Style:	one output, with inverting transformer accessory.
Double pulse option ⁷ :	Optional. See note 7. Only available on -C models.
Propagation delay:	≤ 70 ns (Ext trig in to pulse out)
Jitter, Ext trig in to pulse out:	±15 ps
DC offset or bias insertion:	Option available. Apply required DC offset or bias in the range of ± 50 Volts (250 mA max) to back panel solder terminal. See note 8.
Trigger required:	ext trig mode: +5 Volt, 50 ns to 500 ns (TTL)
Sync delay:	Variable 0 to 500 ns
Sync output:	+3 Volts, 200 ns, will drive 50Ω
Monitor output option ⁹ :	Provides a 20 dB (x10) attenuated coincident replica of main output
Connectors:	
OUT	SMA
TRIG	BNC
SYNC	BNC
MONITOR ⁸	SMA
Power requirement:	100 - 240 Volts, 50-60 Hz
Dimensions (H x W x D):	dual-polarity -C units: 100 mm x 430 mm x 375 mm (3.9" x 17" x 14.8") single-polarity -C units: 100 mm x 215 mm x 375 mm (3.9" x 8.5" x 14.8")
Chassis material:	anodized aluminum, with blue plastic trim
Mounting, Temp. range:	Any, +5° to +40° C

1. -C suffix indicates stand-alone lab instrument with internal clock and line powering.
-PS suffix indicates line powered instrument requiring external trigger. No suffix indicates miniature module requiring DC power and external trigger. (See page 112 for additional details of the four basic instrument formats).
2. -B suffix indicates IEEE-488.2 GPIB and RS-232 control of amplitude, pulse width, PRF and delay (See page 8).
3. For analog electronic control (0 to +10V) of amplitude, pulse width or DC offset suffix model number with -EA or -EW or -EO. Electronic control units also include standard front-panel controls. -EW not available on -B units.
4. For operation at amplitudes of less than 10% of full-scale, best results will be obtained by setting the amplitude near full-scale and using external attenuators on the output.
5. For 20-500 ns pulse width, suffix model number with -W. Rise time and fall time increase to 150 ps and 200 ps for -W units. -W units have propagation delay of 30 ns.
6. Indicate desired polarity by suffixing model number by -P or -N (i.e. positive or negative) or -P-PN or -N-PN for dual polarity option where the suffix preceding -PN indicates the polarity at the mainframe output port.
8. For double pulse option add suffix -DP. Rise and fall times for units with this option fixed at 300 ps. Units with this option have a maximum output amplitude of 70% of the rated maximum amplitude (except when the relative time delay is set to zero, in which case the addition of the two coincident pulses allows 140% of the rated amplitude to be obtained).
9. For externally applied DC offset option suffix model number with -OS. The Avtech AVX-T bias tee can also be used to obtain DC offset. For internally generated DC offset option (0 to ±5V) add suffix -OT or -EO to model number. (The -OT option is controlled by a front-panel dial, whereas the -EO option can be controlled by a front-panel dial or by an external 0 to +10V voltage). -OT, -EO not available on modules.
10. For monitor option add suffix -M.
11. For ECL trigger option, add suffix -ECL.

EC DECLARATION OF CONFORMITY

We

Avtech Electrosystems Ltd.
P.O. Box 5120, LCD Merivale
Ottawa, Ontario
Canada K2C 3H4

declare that this pulse generator meets the intent of Directive 89/336/EEC for Electromagnetic Compatibility. Compliance pertains to the following specifications as listed in the official Journal of the European Communities:

EN 50081-1 Emission

EN 50082-1 Immunity

and that this pulse generator meets the intent of the Low Voltage Directive 72/23/EEC as amended by 93/68/EEC. Compliance pertains to the following specifications as listed in the official Journal of the European Communities:

EN 61010-1:2001 Safety requirements for electrical equipment for measurement, control, and laboratory use



INSTALLATION

VISUAL CHECK

After unpacking the instrument mainframe and the transformer module, examine to ensure that they have not been damaged in shipment. Visually inspect all connectors, knobs, and handles. Confirm that a power cord and an instrumentation manual (this manual), are with the instrument. If the instrument has been damaged, file a claim immediately with the company that transported the instrument.

POWER RATINGS

This instrument is intended to operate from 100 - 240 V, 50 - 60 Hz.

The maximum power consumption is 57 Watts. Please see the "FUSES" section for information about the appropriate AC and DC fuses.

This instrument is an "Installation Category II" instrument, intended for operation from a normal single-phase supply.

CONNECTION TO THE POWER SUPPLY

An IEC-320 three-pronged recessed male socket is provided on the back panel for AC power connection to the instrument. One end of the detachable power cord that is supplied with the instrument plugs into this socket. The other end of the detachable power cord plugs into the local mains supply. Use only the cable supplied with the instrument. The mains supply must be earthed, and the cable used to connect the instrument to the mains supply must provide an earth connection. (The supplied cable does this.)

ENVIRONMENTAL CONDITIONS

This instrument is intended for use under the following conditions:

- a) indoor use;
- b) altitude up to 2 000 m;
- c) temperature 5 °C to 40 °C;
- d) maximum relative humidity 80 % for temperatures up to 31 °C decreasing linearly to 50 % relative humidity at 40 °C;
- e) Mains supply voltage fluctuations up to ± 10 % of the nominal voltage;
- f) no pollution or only dry, non-conductive pollution.

FUSES

This instrument contains four fuses. All are accessible from the rear-panel. Two protect the AC prime power input, and two protect the internal DC power supplies. The locations of the fuses on the rear panel are shown in the figure below:

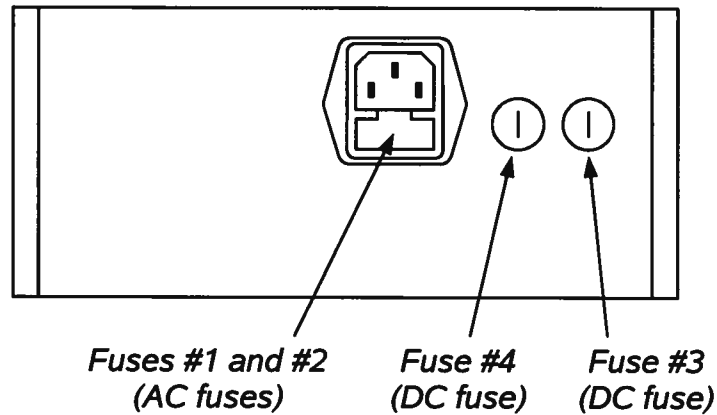

AC FUSE REPLACEMENT

To physically access the AC fuses, the power cord must be detached from the rear panel of the instrument. The fuse drawer may then be extracted using a small flat-head screwdriver, as shown below:

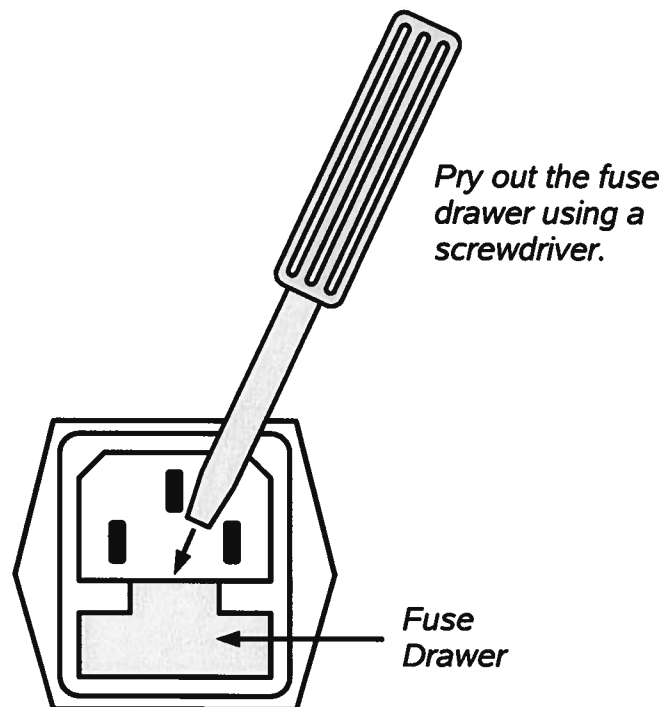

DC FUSE REPLACEMENT

The DC fuses may be replaced by inserting the tip of a flat-head screwdriver into the fuse holder slot, and rotating the slot counter-clockwise. The fuse and its carrier will then pop out.

FUSE RATINGS

The following table lists the required fuses:

Fuses	Nominal Mains Voltage	Rating	Case Size	Manufacturer's Part Number (Wickmann)	Distributor's Part Number (Digi-Key)
#1, #2 (AC)	100-240V	0.5A, 250V, Time-Delay	5×20 mm	1950500000	WK5041-ND
#3 (DC)	N/A	0.8A, 250V, Time-Delay	5×20 mm	1950800000	WK5046-ND
#4 (DC)	N/A	0.5A, 250V, Time-Delay	5×20 mm	1950500000	WK5041-ND

The fuse manufacturer is Wickmann (<http://www.wickmann.com/>).

Replacement fuses may be easily obtained from Digi-Key (<http://www.digikey.com/>) and other distributors.

FRONT PANEL CONTROLS

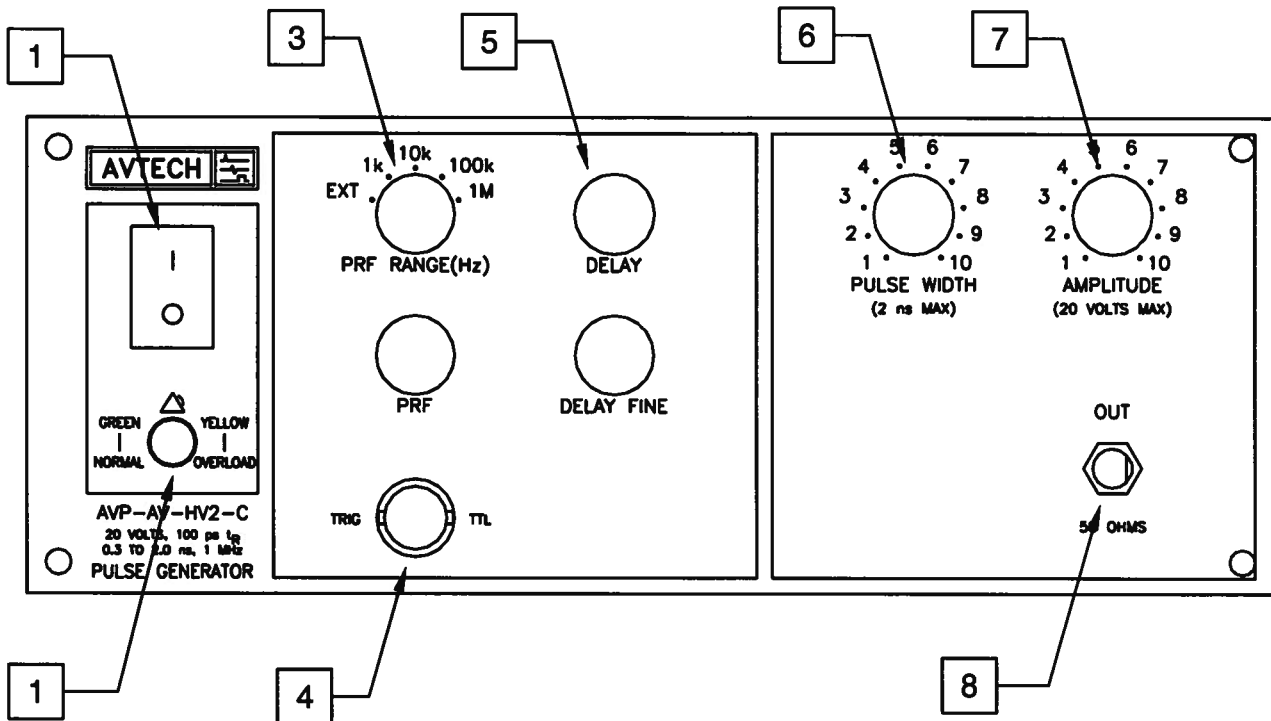

- 1) **POWER Switch**. This is the main power switch. When turning the instrument on, there may be a delay of several seconds before the instrument appears to respond.
- 2) **OVERLOAD Indicator**. When the instrument is powered, this indicator is normally green, indicating normal operation. If this indicator is yellow, an internal automatic overload protection circuit has been tripped. If the unit is overloaded (by operating at an exceedingly high duty cycle or by operating into a very low impedance), the protective circuit will disable the output of the instrument and turn the indicator light yellow. The light will stay yellow (i.e. output disabled) for about 5 seconds after which the instrument will attempt to re-enable the output (i.e. light green) for about 1 second. If the overload condition persists, the output will be disabled again (i.e. light yellow) for another 5 seconds. If the overload condition has been removed, the instrument will resume normal operation.

This overload indicator may flash yellow briefly at start-up. This is not a cause for concern.

- 3) **PRF Range Switch**. This switch sets the pulse repetition frequency (PRF) range of the internal oscillator. The marked value of each position is the upper limit of the 10:1 range, approximately. The vernier dial directly below the switch varies the PRF within the set range.

If this switch is set to the "EXT" position, the instrument is triggered by a signal applied to the TRIG connector, rather than by the internal oscillator.

- 4) TRIG Connector. When the PRF Range Switch is set to "EXT", the instrument is triggered by a TTL pulse applied to this connector. The pulse must be at least 50 ns wide.

When the PRF Range Switch is set to one of the four internal oscillator ranges, this connector is an output, which supplies a 2V, 200 ns wide pulse for each trigger event. This output may be used to trigger oscilloscopes or other equipment.

- 5) Delay Controls. When the PRF Range Switch is set to one of the four internal oscillator ranges, the main output is advanced or delayed relative to the TRIG output pulse (item 4). The delay is variable up to 200 ns, approximately, using the DELAY and DELAY FINE dials.
- 6) Pulse Width Control. This dial controls the pulse width.
- 7) Amplitude Control. This dial controls the pulse amplitude.
- 8) OUT Connector. This SMA connector provides the main output. This output *requires* a 50 Ω load to function properly

REAR PANEL CONTROLS

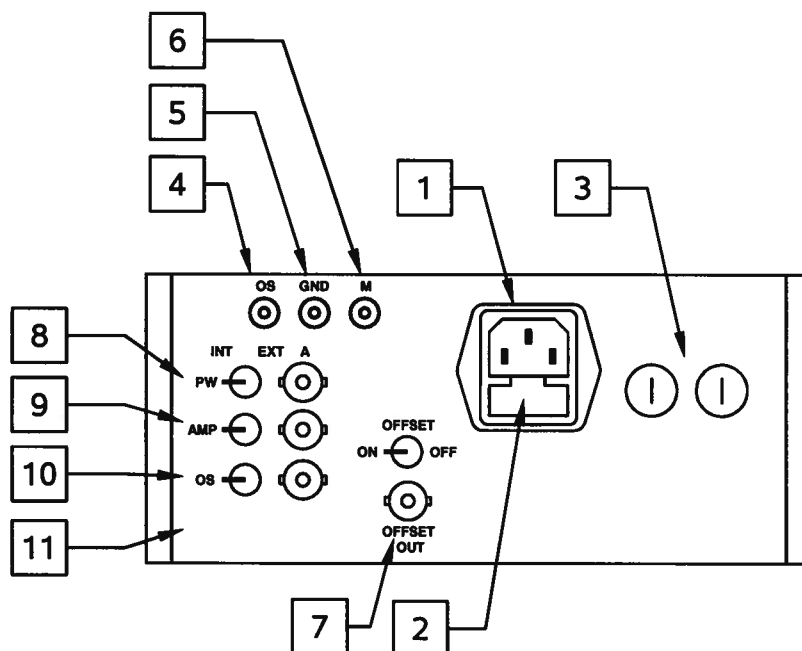

1. **AC POWER INPUT.** An IEC-320 C14 three-pronged recessed male socket is provided on the back panel for AC power connection to the instrument. One end of the detachable power cord that is supplied with the instrument plugs into this socket.
2. **AC FUSE DRAWER.** The two fuses that protect the AC input are located in this drawer. Please see the “FUSES” section of this manual for more information.
3. **DC FUSES.** These two fuses protect the internal DC power supplies. Please see the “FUSES” sections of this manual for more information.
4. **OS INPUT CONNECTOR.** A DC offset in the range of $\pm 50\text{V}$ (250 mA max) may be applied to this solder terminal. The DC offset will appear on the output. When this feature is not used, the OS input should be connected to ground (using the adjacent GND connector). This is especially important when driving loads containing a diode.
5. **GND CONNECTOR.** This solder terminal is connected to ground. It may be used to ground the OS input connector.
6. **M OUTPUT CONNECTOR.** (Present on units with -M option only.) This SMA connector output provides a 20 dB attenuated coincident replica of main output, for monitoring purposes.
7. **OFFSET ON/OFF SWITCH & OUTPUT** (Optional, -EO and -OT units only). This switch enables the offset feature when it is set to “ON”. When it is set to “OFF”, no offset is added to the output. The internally generated offset is available at the “OFFSET OUT” BNC connector, for monitoring purposes. To add an offset to

inverted pulses on AVM units with the dual polarity option (-PN), connect this terminal to the DC terminal of the AVX-2-T inverting transformer (see the "POLARITY INVERSION" sections in this manual for further details).

8. PW INT/EXT SWITCH AND CONNECTOR (Optional, -EW units only). To control the pulse width of the output with an external DC voltage, set the two-position switch to the EXT position and apply 0 to +10V to the BNC Connector ($R_{IN} \geq 10 \text{ k}\Omega$). When this switch is in the "INT" position, the pulse width is controlled by the front-panel controls.
9. AMP INT/EXT SWITCH AND CONNECTOR (Optional, -EA units only). To control the amplitude of the output with an external DC voltage, set the two-position switch to the EXT position and apply 0 to +10V to the BNC Connector ($R_{IN} \geq 10 \text{ k}\Omega$). When this switch is in the "INT" position, the amplitude is controlled by the front-panel controls.
10. OS INT/EXT SWITCH AND CONNECTOR (Optional, -EO units only). To control the offset of the output with an external DC voltage, set the two-position switch to the EXT position and apply 0 to +10V to the BNC Connector ($R_{IN} \geq 10 \text{ k}\Omega$). When this switch is in the "INT" position, the offset is controlled by the front-panel controls.

GENERAL INFORMATION

BASIC TEST ARRANGEMENT

The AVP-AV-HV2-C should be tested with a sampling oscilloscope with a bandwidth of at least 10 GHz to properly observe the high-speed waveform. (The cables and attenuators must also have a bandwidth of at least 10 GHz.) A typical test arrangement is shown below:

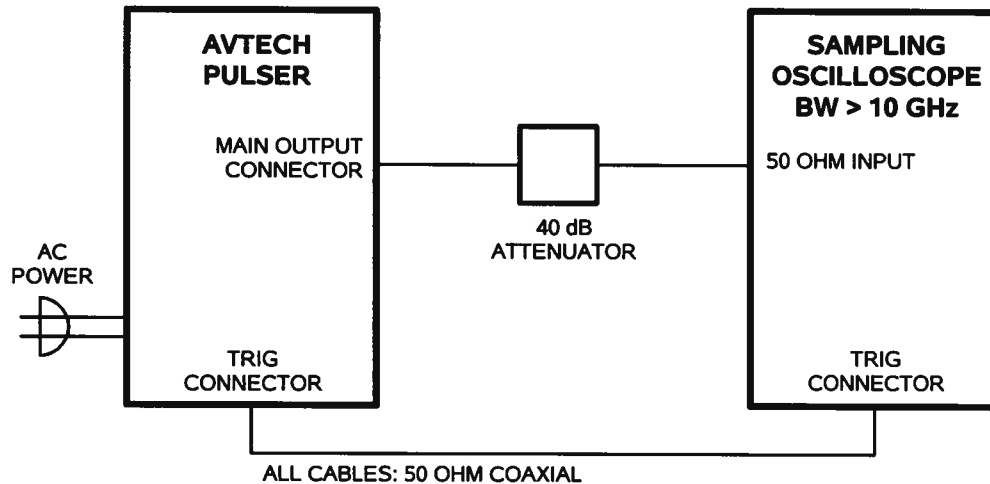

The attenuators are required to prevent damage to the sampling oscilloscope. A 40 dB attenuator with sufficient voltage rating should be used on the main output.

BASIC PULSE CONTROL

This instrument can be triggered by its own internal clock or by an external TTL trigger signal. When triggered internally, two mainframe output channels respond to the trigger: OUT and SYNC.

- OUT. This is the main output. The maximum output voltage is 20V.
- TRIG. The TRIG pulse is a fixed-width TTL-level reference pulse used to trigger oscilloscopes or other measurement systems.

The TRIG output precedes the main output. These pulses are illustrated below:

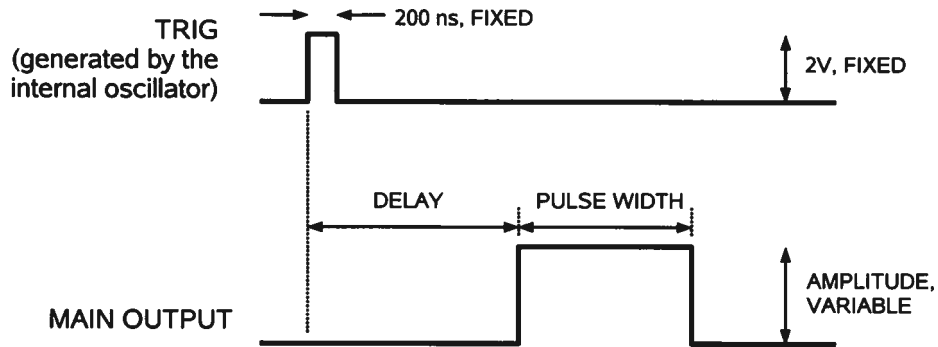

When triggered externally, the TRIG connector acts as an input. The delay controls do not function in this mode. This illustrated below:

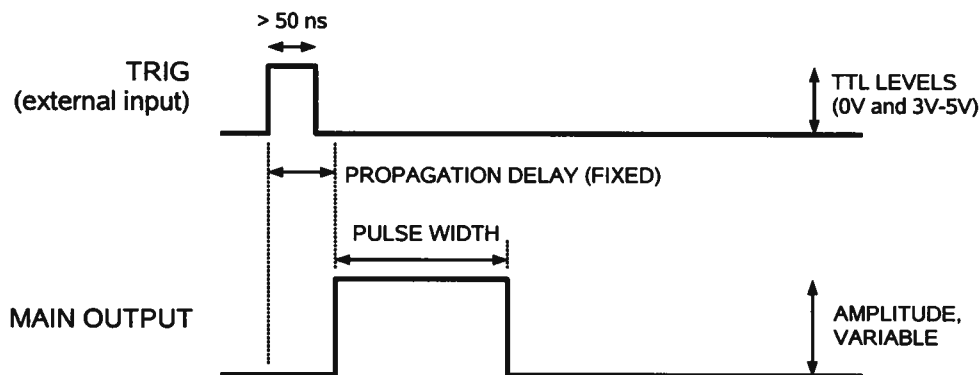

AMPLITUDE INTERACTION

Some properties of the output pulse may change as a function of the amplitude setting. For some demanding applications, it may be desirable to use a combination of external attenuators and the amplitude pot to achieve the desired output amplitude.

POLARITY INVERSION

Instruments with the "-P-PN" suffix generate 0 to +20V at the main output, and are supplied with an inverting transformer that can be installed on the mainframe output. A negative pulse is then obtained at the out port of the transformer module.

Instruments with the "-N-PN" suffix generate 0 to -20V at the main output, and are supplied with an inverting transformer that can be installed on the mainframe output. A positive pulse is then obtained at the out port of the transformer module.

When using the transformer with dual-polarity models with the "-OS" option, the external offset must be added to the DC terminal of the inverting transformer. Do not apply the offset to the rear-panel offset terminal on the mainframe (if present).

MINIMIZING WAVEFORM DISTORTIONS

USE 50Ω TRANSMISSION LINES AND LOADS

Connect the load to the pulse generator with 50Ω transmission lines (e.g. RG-58 or RG-174 cable).

This instrument requires a 50Ω load for proper operation. It will not properly drive a high-impedance load. The output stage will be damaged if it is operated into an open circuit (or any other high impedance). Failures due to improper output loading are not covered by the warranty.

USE LOW-INDUCTANCE LOADS

Lenz's Law predicts that for an inductive voltage spike will be generated when the current through an inductance changes. Specifically, $V_{\text{SPIKE}} = L \times di_{\text{LOAD}}/dt$, where L is the inductance, i_{LOAD} is the load current change, and t is time. For this reason, it is important to keep any parasitic in the load low. This means keeping wiring short, and using low inductance components. In particular, wire-wound resistors should be avoided.

PREVENTING DAMAGE

The AVP-AV-HV2-C may fail if triggered at a PRF greater than 1 MHz.

This unit is designed to operate into a load impedance of 50 Ohms and the output stage will be damaged if it is operated into an open circuit (or any other high impedance). Failures due to improper output loading are not covered by the warranty.

The lifetime of the switching elements in the pulse generator module is proportional to the running time of the instrument. For this reason the prime power to the instrument should be turned off when the instrument is not in use.

MECHANICAL INFORMATION

TOP COVER REMOVAL

If necessary, the interior of the instrument may be accessed by removing the four Phillips screws on the top panel. With the four screws removed, the top cover may be slid back (and off).

Always disconnect the power cord before opening the instrument.

There are no user-adjustable internal circuits. For repairs other than fuse replacement, please contact Avtech (info@avtechpulse.com) to arrange for the instrument to be returned to the factory for repair.

 **Caution:** High voltages are present inside the instrument during normal operation. Do not operate the instrument with the cover removed.

ELECTROMAGNETIC INTERFERENCE

To prevent electromagnetic interference with other equipment, all used outputs should be connected to shielded 50Ω loads using shielded 50Ω coaxial cables. Unused outputs should be terminated with shielded 50Ω coaxial terminators or with shielded coaxial dust caps, to prevent unintentional electromagnetic radiation. All cords and cables should be less than 3m in length.

MAINTENANCE

REGULAR MAINTENANCE

This instrument does not require any regular maintenance.

On occasion, one or more of the four rear-panel fuses may require replacement. All fuses can be accessed from the rear panel. See the “FUSES” section for details.

CLEANING

If desired, the interior of the instrument may be cleaned using compressed air to dislodge any accumulated dust. (See the “TOP COVER REMOVAL” section for instructions on accessing the interior.) No other cleaning is recommended.

Aug 30/2004