



AVTECH ELECTROSYSTEMS LTD.

NANOSECOND WAVEFORM ELECTRONICS
SINCE 1975

P.O. BOX 265
OGDENSBURG, NY
U.S.A. 13669-0265
TEL: (315) 472-5270
FAX: (613) 226-2802

TEL: 1-800-265-6681
FAX: 1-800-561-1970

e-mail: info@avtechpulse.com
<http://www.avtechpulse.com>

P.O. BOX 5120 STN. F
OTTAWA, ONTARIO
CANADA K2C 3H4
TEL: (613) 226-5772
FAX: (613) 226-2802

INSTRUCTIONS

MODEL AVR-3-C-GA3-P PULSE GENERATOR

S.N.:

WARRANTY

Avtech Electrosystems Ltd. warrants products of its manufacture to be free from defects in material and workmanship under conditions of normal use. If, within one year after delivery to the original owner, and after prepaid return by the original owner, this Avtech product is found to be defective, Avtech shall at its option repair or replace said defective item. This warranty does not apply to units which have been disassembled, modified or subjected to conditions exceeding the applicable specifications or ratings. This warranty is the extent of the obligation assumed by Avtech with respect to this product and no other warranty or guarantee is either expressed or implied.

TECHNICAL SUPPORT

Phone: 613-226-5772 or 1-800-265-6681

Fax: 613-226-2802 or 1-800-561-1970

E-mail: info@avtechpulse.com

World Wide Web: <http://www.avtechpulse.com>

TABLE OF CONTENTS

WARRANTY	2
TABLE OF CONTENTS	3
FIG. 1: PULSE GENERATOR TEST ARRANGEMENT	4
GENERAL OPERATING INSTRUCTIONS	5
FIG. 2: FRONT PANEL CONTROLS	8
FRONT PANEL CONTROLS	9
FIG. 3: BACK PANEL CONTROLS	12
BACK PANEL CONTROLS	13
TOP COVER REMOVAL AND RACK MOUNTING	14
ORIGINAL QUOTATION	15
PERFORMANCE CHECK SHEET	16

FIG. 1: PULSE GENERATOR TEST ARRANGEMENT

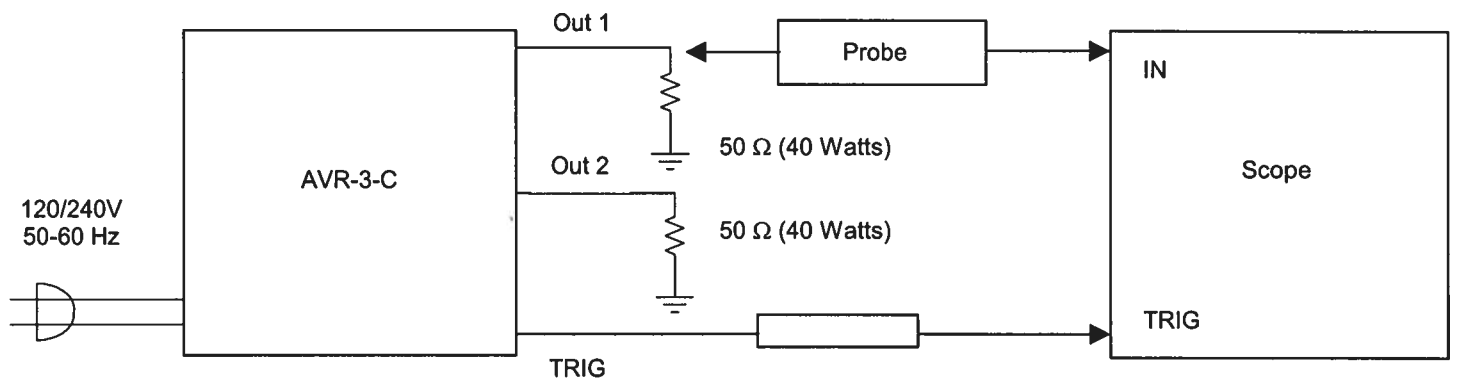

GENERAL OPERATING INSTRUCTIONS

- 1) **CAUTION:** EXTREME CAUTION SHOULD BE FOLLOWED WHEN USING THIS INSTRUMENT AS IT GENERATES OUTPUT PULSE AMPLITUDES AS HIGH AS 200 VOLTS.
- 2) The bandwidth capability of components and instruments used to display the pulse generator output signal (attenuators, cables, connectors, etc.) should exceed 100 MHz.
- 3) The TRIG output channel provides TTL level signals. To avoid overdriving the TRIG input channel of some scopes, a 30 dB attenuator should be placed at the input to the scope trigger channel. The TRIG output precedes the main output when the front panel ADVANCE-DELAY switch is in the ADVANCE position. The TRIG output lags the main output when the switch is in the DELAY position.

The DELAY control controls the relative delay between the reference output pulse provided at the TRIG output and the main output. This delay is variable over the range of 0.05 us to 50 us.

	MIN	MAX
Range 1	0.05 us	0.5 us
Range 2	0.5 us	5 us
Range 3	5 us	50 us

- 4) The output pulse widths are controlled by means of two independent front panel ten-turn PW controls and by two PW RANGE controls. Note that the MODE switch must be in the INT position. The minimum and maximum PW for each range and the corresponding maximum PRF are as follows. Note that the unit may fail if operated at duty cycles exceeding 5%.

	PW min	PW max
Range 1	0.05 us PRF max 5 kHz	0.5 us PRF max 5 kHz
Range 2	0.5 us PRF max 5 kHz	5 us PRF max 4 kHz
Range 3	5 us PRF max 4 kHz	50 us PRF max 400 Hz

- 5) To obtain a stable output display the PRF control on the front panel should be set mid range. The front panel MODE switch should be in the INT position. The DELAY controls and the scope triggering controls are then adjusted to obtain a stable output. The scope may then be used to set the desired PRF by rotating the PRF controls.
- 6) The output pulse amplitudes are controlled by means of two independent front panel ten-turn AMP controls.
- 7) An external clock may be used to control the output PRF of the AVR unit by setting the front panel MODE switch in the EXT position and applying a 50 ns (or wider) TTL level pulse to the TRIG BNC connector input. With the MODE switch in the EXT A position, the output pulse width will be controlled by the front panel PW controls. If the switch is in the EXT B position, the output pulse width equals the input trigger pulse width.
- 8) For single pulse manual operation, set the front panel MODE switch in the MAN position and push the SINGLE PULSE button.
- 9) The AVR-3-C features output impedance of the order of several Ohms (rather than 50 Ohms). The following consequences of this feature should be noted:
 - a) When used to switch some semiconductor devices (eg. Bipolar and VMOS power transistors), the AVR unit will yield much faster switching times than those provided by 50 Ohm pulse generators.
 - b) The AVR unit will safely operate into load impedances in the range of 50 Ohms to an open circuit. However, the fall time may degrade for load impedances higher than 50 Ohms.
 - c) The AVR unit may be effectively converted to a fifty-Ohm output impedance generator by placing a fifty-Ohm carbon composition resistor in series with the output of the unit and the load. The maximum available load voltage will then decrease to 100 Volts (from 200 Volts).
- 10) **OVERLOAD**. An automatic overload protective circuit controls the front panel overload light. If the unit is overloaded (by operating at an exceedingly high duty cycle or by operating into a very low impedance), the protective circuit will turn the output of the instrument OFF and turn the indicator light ON. The light will stay ON (i.e. output OFF) for about 5 seconds after which the instrument will attempt to turn ON (i.e. light OFF) for about 1 second. If the overload condition persists, the instrument will turn OFF again (i.e. light ON) for another 5 seconds. If the overload condition has been removed, the

instrument will turn on and resume normal operation. Overload conditions may be removed by:

- 1) Reducing PRF (i.e. switch to a lower range)
- 2) Reducing pulse width (i.e. switch to a lower range)
- 3) Removing output load short circuit (if any)
- 4) Reducing the output amplitude (i.e. switch to a lower range).

The overload light may illuminate when the prime power is first applied. The light will extinguish after a few seconds and the unit will then operate normally.

Note that the output stage will safely withstand a short-circuited load condition.

- 11) **CAUTION:** DC potentials as high as 225 Volts exist in the interior of the instrument. For this reason it is recommended that the top cover of the unit should not be removed and that the unit should be returned to the factory for servicing (when necessary).
- 12) The unit can be converted from 120 to 240V 50-60 Hz operation by adjusting the voltage selector card in the rear panel fused voltage selector cable connector assembly.
- 13) For further assistance:

Tel: 613-226-5772
Fax: 613-226-2802
Email: info@avtechpulse.com

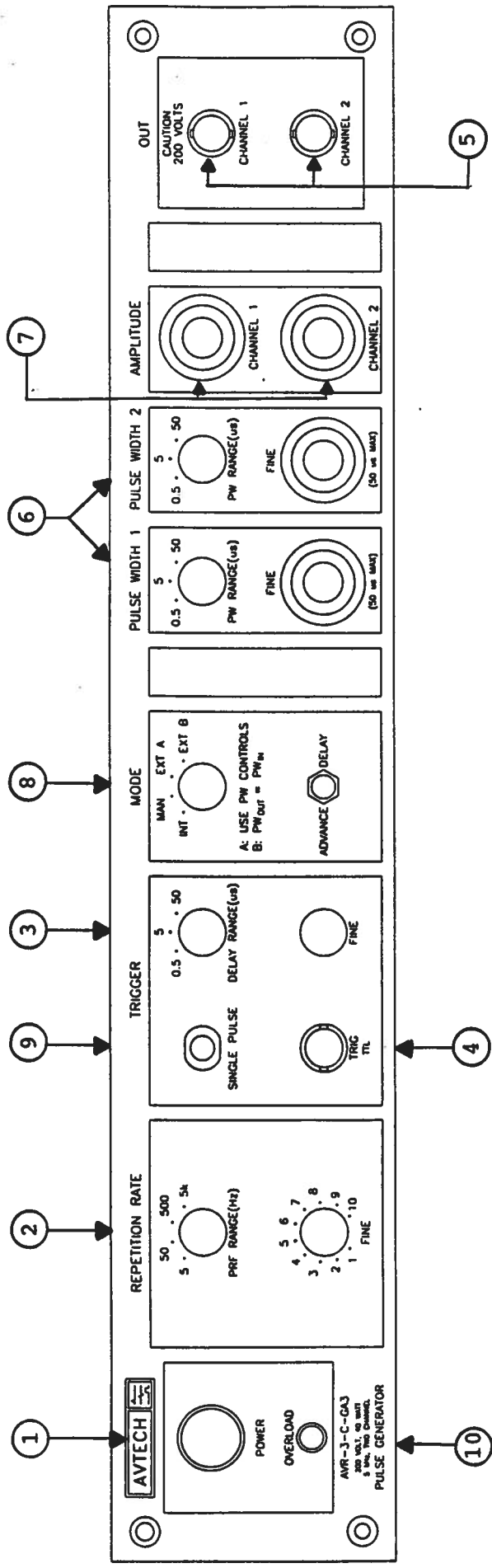

FIG. 2: FRONT PANEL CONTROLS

FRONT PANEL CONTROLS

(1) ON-OFF Switch. Applies basic prime power to all stages.

(2) PRF Control. Varies PRF from 0.5 Hz to 5 kHz as follows:

Range 1	0.5 Hz	5 Hz
Range 2	5 Hz	50 Hz
Range 3	50 Hz	0.5 kHz
Range 4	0.5 kHz	5 kHz

(3) DELAY Control. Controls the relative delay between the reference output pulse provided at the TRIG output (4) and the main output (5). This delay is variable over the range of 0.05 to about 50 us. Delay LEADS or LAGS depending on the position of the ADVANCE-DELAY switch.

	MIN	MAX
Range 1	0.05 us	0.5 us
Range 2	0.5 us	5 us
Range 3	5 us	500 us

(4) TRIG Output. This output is used to trigger the scope time base. The output is a TTL level 100 ns (approx.) pulse capable of driving a fifty-Ohm load. This output precedes the output at (5) if the two-position ADVANCE-DELAY switch is in the ADVANCE position. This output follows the output at (5) if the switch is in the DELAY position. The delay range is variable from 0.05 us to 50 us. The external trigger signal is applied at this input when the EXT-INT toggle switch is in the EXT position.

(5) OUT Connector. Two BNC connectors provide outputs to 50-Ohm (or higher) loads.

- (6) **PW Control.** Two independent ten-turn control and 3-position range switches which vary the output pulse width from 0.05 μ s to 50 μ s (when the MODE switch is in the INT position). The minimum and maximum PW for each range and the corresponding maximum PRF are as follows. Note that the unit may fail if operated at duty cycles exceed 5%.

	PW min	PW max
Range 1	0.05 μ s PRF max 10 kHz	0.5 μ s PRF max 5 kHz
Range 2	0.5 μ s PRF max 5 kHz	5 μ s PRF max 4 kHz
Range 3	5 μ s PRF max 4 kHz	50 μ s PRF max 400 Hz

- (7) **AMP Controls.** Two ten-turn controls, which vary the output pulse amplitudes from 0 to 200 V.
- (8) **MODE.** With this switch in the INT position, the PRF of the AVR unit is controlled via an internal clock, which in turn is controlled by the PRF control. With the switch in the EXT position, the AVR unit requires a 50 ns (or wider) TTL level pulse applied at the TRIG input in order to trigger the output stages. In addition, in this mode, the scope time base must be triggered by the external trigger source. With the MODE switch in the EXT A position the output pulse width is controlled by the PW controls. With the MODE switch in the EXT B position, the output pulse width equals the input trigger pulse width. For single pulse operation, set the MODE switch in the MAN position.
- (9) **SINGLE PULSE.** For single pulse manual operation, set the front panel INT-EXT-MAN switch in the MAN position and push the SINGLE PULSE button.
- 10) **OVERLOAD.** An automatic overload protective circuit controls the front panel overload light. If the unit is overloaded (by operating at an exceedingly high duty cycle or by operating into a very low impedance), the protective circuit will turn the output of the instrument OFF and turn the indicator light ON. The light will stay ON (i.e. output OFF) for about 5 seconds after which the instrument will attempt to turn ON (i.e. light OFF) for about 1 second. If the overload condition persists, the instrument will turn OFF again (i.e. light ON) for another 5 seconds. If the overload condition has been removed, the instrument will turn on and resume normal operation. Overload conditions may be removed by:

- 1) Reducing PRF (i.e. switch to a lower range)
- 2) Reducing pulse width (i.e. switch to a lower range)
- 3) Removing output load short circuit (if any)
- 4) Reducing the output amplitude (i.e. switch to a lower range)

The overload light may illuminate when the prime power is first applied. The light will extinguish after a few seconds and the unit will then operate normally.

Note that the output stage will safely withstand a short-circuited load condition.

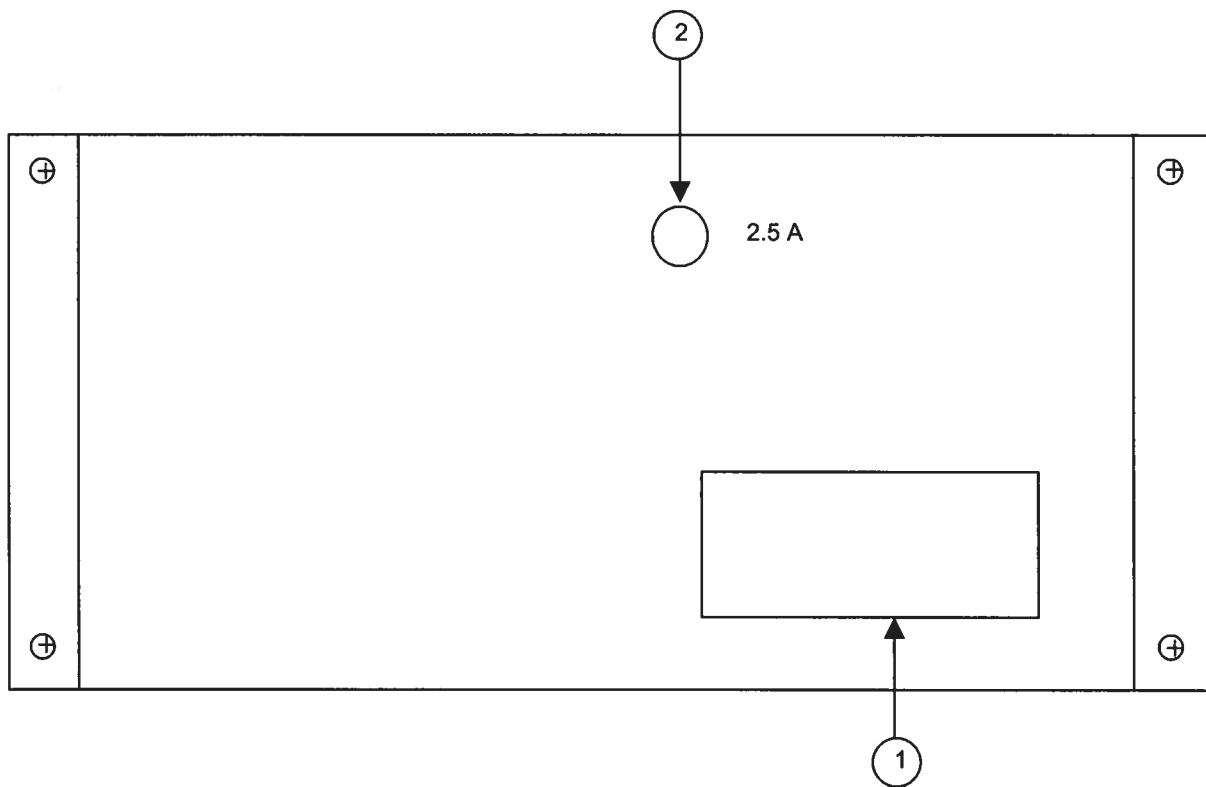
FIG. 3: BACK PANEL CONTROLS

BACK PANEL CONTROLS

- (1) FUSED CONNECTOR, VOLTAGE SELECTOR. The detachable power cord is connected at this point. In addition, the removable cord is adjusted to select the desired input operating voltage. The unit also contains the main power fuse.

For AC line voltages of 110-120V, the power selector card should be installed so that the "120" marking is visible from the rear of the instrument.

For AC line voltages of 220-240V, the power selector card should be installed so that the "240" marking is visible from the rear of the instrument.

If it is not set for the proper voltage, remove the fuse and then grasp the card with a pair of pliers and remove it. Rotate horizontally through 180 degrees. Reinstall the card and the correct fuse.

In the 120V setting, a 1.0A slow blow fuse is required. In the 240V setting, a 0.5A slow blow fuse is required.

- (2) 2.5A SB FUSE. This fuse limits the current supplied to the output stage.

TOP COVER REMOVAL AND RACK MOUNTING

- 1) The interior of the instrument may be accessed by removing the four Phillips screws on the top panel. With the four screws removed, the top cover may be slid back (and off).
- 2) The -R5 rack mount kit may be installed after first removing the one Phillips screw on the side panel adjacent to the front handle.

Walter Chudobiak

From: Avtech Sales
Sent: Wednesday, January 03, 2001 9:51 AM
To: 'Lubos.Hvozدارa@chemistry.gatech.edu'
Subject: Price and Delivery Quotation

January 3, 2001

Dear Lubos,

1) We are pleased to re-quote on the following high duty cycle special:

Quote No: 10190-A
Model Designation: AVR-3-C-GA2
No. of Output Channels: Two.
Output Amplitude: 0 to +200 Volts to RL >/- 50 Ohm
(two independent controls)
Pulse Width: 50 ns to 50 us
(one common controls)
PRF: 0 to 5 KHz
Maximum Duty Cycle: 5%
Rise, Fall Time: 10 ns
Maximum Average Output Power: 40 Watts
Other: See the standard Model AVR-3-C
Price: \$8,998.00 US, FOB: Destination
Delivery: 60 days, after receipt of order

2) Quote No: 10190-B
Model Designation: AVR-3-C-GA3
Basic Description: As per AVR-3-C-GA2 but with two independent pulse width controls.
Price: \$9,448.00 US, FOB: Destination
Delivery: 60 days, after receipt of order

3) Please note that the above quotes include our standard 5% academic discount. Please call me if you require any additional information.

Regards,

Dr. Walter Chudobiak
Chief Engineer

--- Avtech Electrosystems Ltd. ----- since 1975 ---

PO Box 265 ph: 1-800-265-6681 or 613-226-5772 Box 5120 Stn. F
Ogdensburg, NY fax: 1-800-561-1970 or 613-226-2802 Ottawa, Ontario
USA 13669-0265 email: info@avtechpulse.com Canada K2C 3H4
http://www.avtechpulse.com/

Nanosecond Waveform Generators
for general purpose, R&D and OEM applications

Pulse Generators - Laser Diode Drivers - Pulse Amplifiers
Impulse Generators - Delay Generators - Comb Generators - Splitters
Function Generators - Monocycle Generators - Frequency Dividers + more!

August 8/2001
(edition 1)