



AVTECH ELECTROSYSTEMS LTD.

NANOSECOND WAVEFORM ELECTRONICS
SINCE 1975

P.O. BOX 265
OGDENSBURG, NY
U.S.A. 13669-0265

TEL: 888-670-8729 (USA & Canada) or +1-613-226-5772 (Intl)
FAX: 800-561-1970 (USA & Canada) or +1-613-226-2802 (Intl)

info@avtechpulse.com - <http://www.avtechpulse.com/>

BOX 5120, LCD MERIVALE
OTTAWA, ONTARIO
CANADA K2C 3H4

INSTRUCTIONS

MODEL AVR-D2-C

HIGH SPEED PULSE GENERATOR

FOR MIL-PRF-19500

TRANSISTOR SWITCHING TIME TESTS

SERIAL NUMBER: _____

WARRANTY

Avtech Electrosystems Ltd. warrants products of its manufacture to be free from defects in material and workmanship under conditions of normal use. If, within one year after delivery to the original owner, and after prepaid return by the original owner, this Avtech product is found to be defective, Avtech shall at its option repair or replace said defective item. This warranty does not apply to units which have been disassembled, modified or subjected to conditions exceeding the applicable specifications or ratings. This warranty is the extent of the obligation assumed by Avtech with respect to this product and no other warranty or guarantee is either expressed or implied.

TECHNICAL SUPPORT

Phone: 888-670-8729 (USA & Canada) or +1-613-226-5772 (Intl)

Fax: 800-561-1970 (USA & Canada) or +1-613-226-2802 (Intl)

E-mail: info@avtechpulse.com

World Wide Web: <http://www.avtechpulse.com>

TABLE OF CONTENTS

WARRANTY.....	2
TECHNICAL SUPPORT.....	2
TABLE OF CONTENTS.....	3
INTRODUCTION.....	5
SPECIFICATIONS.....	6
EUROPEAN REGULATORY NOTES.....	7
EC DECLARATION OF CONFORMITY.....	7
DIRECTIVE 2002/95/EC (RoHS).....	7
DIRECTIVE 2002/96/EC (WEEE).....	7
INSTALLATION.....	9
VISUAL CHECK.....	9
POWER RATINGS.....	9
CONNECTION TO THE POWER SUPPLY.....	9
PROTECTION FROM ELECTRIC SHOCK.....	10
ENVIRONMENTAL CONDITIONS.....	10
FUSES.....	12
AC FUSE REPLACEMENT.....	12
DC FUSE REPLACEMENT.....	13
FUSE RATINGS.....	13
FRONT PANEL CONTROLS.....	14
REAR PANEL CONTROLS.....	17
GENERAL INFORMATION.....	18
BASIC TEST ARRANGEMENT.....	18
TYPICAL TEST SETUPS.....	18
MINIMIZING WAVEFORM DISTORTIONS.....	20
USE 50 OHM TRANSMISSION LINES AND LOADS.....	20
USE LOW-INDUCTANCE LOADS.....	20
PREVENTING DAMAGE.....	20
MECHANICAL INFORMATION.....	21
TOP COVER REMOVAL.....	21
RACK MOUNTING.....	21
ELECTROMAGNETIC INTERFERENCE.....	21

MAINTENANCE	22
REGULAR MAINTENANCE	22
CLEANING	22
WIRING DIAGRAMS	23
WIRING OF AC POWER, 1/2	23
WIRING OF AC POWER, 2/2	24
PCB 158K - LOW VOLTAGE POWER SUPPLY, 1/3	25
PCB 158K - LOW VOLTAGE POWER SUPPLY, 2/3	26
PCB 158K - LOW VOLTAGE POWER SUPPLY, 3/3	27
PCB 168B - HIGH VOLTAGE DC POWER SUPPLY	28
PCB 152A - TIMING BOARD (1/2)	29
PCB 152A - TIMING BOARD (2/2)	30
MAIN WIRING	31
PERFORMANCE CHECK SHEET	32

Manual Reference: T:\instructword\avr-d2\AVR-D2-C,edition2.odt.
 Last modified May 23, 2007.
 Copyright © 2007 Avtech Electrosystems Ltd, All Rights Reserved.

INTRODUCTION

The AVR-D2-C is a high performance pulse generator designed to provide waveforms required for a range of MIL-PRF-19500 transistor switching times tests.

The AVR-D2-C provides two output channels (A and B). Both channels have rise and fall times of less than 1 ns, and can operate at pulse repetition frequencies of up to 50 kHz. The active channel provided on the main output connector is switch-selectable.

Channel A has an amplitude adjustable from 0 to ± 30 Volts. The pulse width is adjustable from 200 ns to 20 μ s, subject to a 10% maximum duty cycle limit. An internally-generated DC offset in the range of -15V to +15V may be applied to the output waveform. An example of one application for this output is the "Saturated turn-on switching time test circuit" specified in MIL-PRF-19500/255V Figure 17 for 2N2222A and similar NPN silicon switching transistors.

Channel B has a amplitude of -2V or +2V. The polarity is switchable, but the amplitude is not adjustable. The pulse width 15 ns (± 1 ns), non-adjustable. An internally-generated DC offset in the range of -1V to +1V may be applied to the output waveform. An example of one application for this output is the "Nonsaturated switching time test circuit" specified in MIL-PRF-19500/177F Figure 2 for 2N1131 and similar PNP silicon low-power transistors.

This instrument is intended for use in research, development, test and calibration laboratories by qualified personnel.

SPECIFICATIONS

Model:	AVR-D2-C ¹
Amplitude, into 50Ω:	Channel A: 0 to ±30 Volts Channel B: 0 to ±2 Volts
Pulse width (FWHM):	Channel A: 200 ns to 20 us Channel B: 15 ns (fixed)
Rise and fall times: (20%-80%)	≤ 1 ns
PRF:	5 Hz to 50 kHz
Duty Cycle:	Channel A: 10% maximum (e.g., max PW = 2 us at 50 kHz, or 10 us at 10 kHz) Channel B: not applicable
Polarity:	Positive or negative, switchable
DC offset, into 50Ω:	Channel A: 0 to ±15 Volts Channel B: 0 to ±1 Volts
Sync output	+3 Volts, 200 ns, will drive 50 Ohm loads
Sync delay:	Sync out to pulse out, variable 0 to ± 20 us
Trigger required:	Ext trig mode: + 5 Volts, 50 ns or wider (TTL)
Propagation delay:	≤ 100 ns (Ext trig in to pulse out)
Jitter:	± 100 ps ± 0.015% of sync delay (Ext trig in to pulse out)
Connectors:	BNC
Power requirement:	100 - 240 Volts, 50 - 60 Hz
Dimensions (H x W x D):	100 × 430 × 375 mm (3.9 × 17 × 14.8")
Chassis material:	cast aluminum frame & handles, blue vinyl on aluminum cover plates
Temperature range:	+5°C to +40°C

1) -C suffix indicates stand-alone lab instrument with internal clock and line powering.

EUROPEAN REGULATORY NOTES

EC DECLARATION OF CONFORMITY

We Avtech Electrosystems Ltd.
 P.O. Box 5120, LCD Merivale
 Ottawa, Ontario
 Canada K2C 3H4

declare that this pulse generator meets the intent of Directive 89/336/EEC for Electromagnetic Compatibility. Compliance pertains to the following specifications as listed in the official Journal of the European Communities:

EN 50081-1 Emission

EN 50082-1 Immunity

and that this pulse generator meets the intent of the Low Voltage Directive 72/23/EEC as amended by 93/68/EEC. Compliance pertains to the following specifications as listed in the official Journal of the European Communities:

EN 61010-1:2001 Safety requirements for electrical equipment for measurement, control, and laboratory use



DIRECTIVE 2002/95/EC (RoHS)

This instrument is exempt from Directive 2002/95/EC of the European Parliament and of the Council of 27 January 2003 on the Restriction of the use of certain Hazardous Substances (RoHS) in electrical and electronic equipment. Specifically, Avtech instruments are considered "Monitoring and control instruments" (Category 9) as defined in Annex 1A of Directive 2002/96/EC. The Directive 2002/95/EC only applies to Directive 2002/96/EC categories 1-7 and 10, as stated in the "Article 2 - Scope" section of Directive 2002/95/EC.

DIRECTIVE 2002/96/EC (WEEE)

European customers who have purchased this equipment directly from Avtech will have completed a "WEEE Responsibility Agreement" form, accepting responsibility for

WEEE compliance (as mandated in Directive 2002/96/EC of the European Union and local laws) on behalf of the customer, as provided for under Article 9 of Directive 2002/96/EC.

Customers who have purchased Avtech equipment through local representatives should consult with the representative to determine who has responsibility for WEEE compliance. Normally, such responsibilities will lie with the representative, unless other arrangements (under Article 9) have been made.

Requirements for WEEE compliance may include registration of products with local governments, reporting of recycling activities to local governments, and financing of recycling activities.



INSTALLATION

VISUAL CHECK

After unpacking the instrument, examine to ensure that it has not been damaged in shipment. Visually inspect all connectors, knobs, and handles. Confirm that a power cord and an instrumentation manual (this manual), are with the instrument. If the instrument has been damaged, file a claim immediately with the company that transported the instrument.

POWER RATINGS

This instrument is intended to operate from 100 - 240 V, 50 - 60 Hz.

The maximum power consumption is 57 Watts. Please see the “FUSES” section for information about the appropriate AC and DC fuses.

This instrument is an “Installation Category II” instrument, intended for operation from a normal single-phase supply.

CONNECTION TO THE POWER SUPPLY

An IEC-320 three-pronged recessed male socket is provided on the back panel for AC power connection to the instrument. One end of the detachable power cord that is supplied with the instrument plugs into this socket. The other end of the detachable power cord plugs into the local mains supply. Use only the cable supplied with the instrument. The mains supply must be earthed, and the cord used to connect the instrument to the mains supply must provide an earth connection. (The supplied cord does this.)

 **Warning:** Failure to use a grounded outlet may result in injury or death due to electric shock. This product uses a power cord with a ground connection. It must be connected to a properly grounded outlet. The instrument chassis is connected to the ground wire in the power cord.

The table below describes the power cord that is normally supplied with this instrument, depending on the destination region:

Destination Region	Description	Manufacturer	Part Number
Continental Europe	European CEE 7/7 "Schuko" 230V, 50Hz	Qualtek (http://www.qualtekusa.com)	319004-T01
United Kingdom	BS 1363, 230V, 50Hz	Qualtek (http://www.qualtekusa.com)	370001-E01
Switzerland	SEV 1011, 2 30V, 50Hz	Volex (http://www.volex.com)	2102H-C3-10
Israel	SI 32, 220V, 50Hz	Volex (http://www.volex.com)	2115H-C3-10
North America, and all other areas	NEMA 5-15, 120V, 60 Hz	Qualtek (http://www.qualtekusa.com)	312007-01

PROTECTION FROM ELECTRIC SHOCK

 Operators of this instrument must be protected from electric shock at all times. The owner must ensure that operators are prevented access and/or are insulated from every connection point. In some cases, connections must be exposed to potential human contact. Operators must be trained to protect themselves from the risk of electric shock. This instrument is intended for use by qualified personnel who recognize shock hazards and are familiar with safety precautions required to avoid possibly injury. In particular, operators should:

1. Keep exposed high-voltage wiring to an absolute minimum.
2. Wherever possible, use shielded connectors and cabling.
3. Connect and disconnect loads and cables only when the instrument is turned off.
4. Keep in mind that all cables, connectors, oscilloscope probes, and loads must have an appropriate voltage rating.
5. Do not attempt any repairs on the instrument, beyond the fuse replacement procedures described in this manual. Contact Avtech technical support (see page 2 for contact information) if the instrument requires servicing. Service is to be performed solely by qualified service personnel.

ENVIRONMENTAL CONDITIONS

This instrument is intended for use under the following conditions:

1. indoor use;
2. altitude up to 2 000 m;
3. temperature 5 °C to 40 °C;

4. maximum relative humidity 80 % for temperatures up to 31 °C decreasing linearly to 50 % relative humidity at 40 °C;
5. Mains supply voltage fluctuations up to ± 10 % of the nominal voltage;
6. no pollution or only dry, non-conductive pollution.

FUSES

This instrument contains four fuses. All are accessible from the rear-panel. Two protect the AC prime power input, and two protect the internal DC power supplies. The locations of the fuses on the rear panel are shown in the figure below:

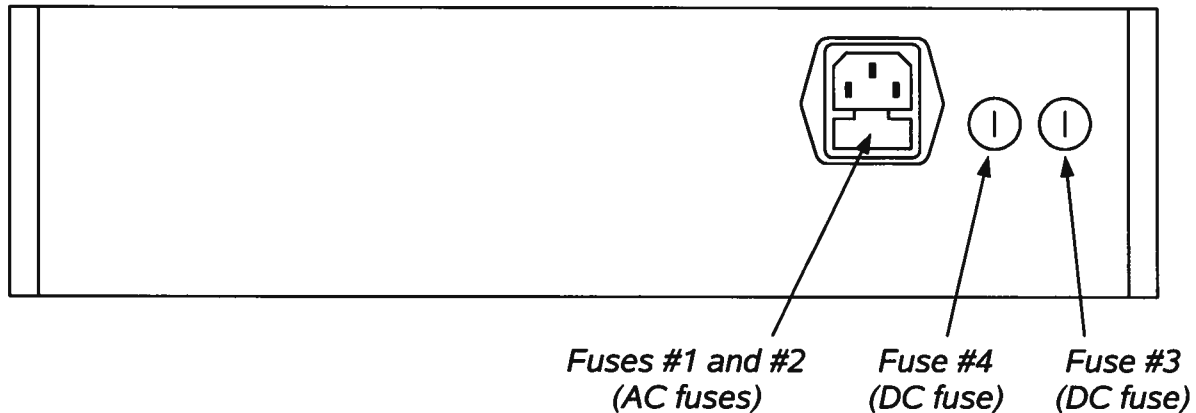

AC FUSE REPLACEMENT

To physically access the AC fuses, the power cord must be detached from the rear panel of the instrument. The fuse drawer may then be extracted using a small flat-head screwdriver, as shown below:

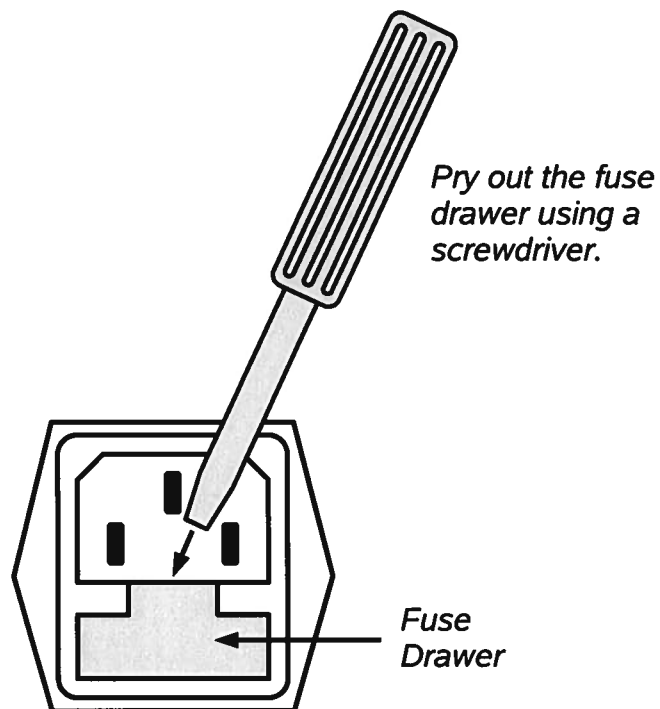

DC FUSE REPLACEMENT

The DC fuses may be replaced by inserting the tip of a flat-head screwdriver into the fuse holder slot, and rotating the slot counter-clockwise. The fuse and its carrier will then pop out.

FUSE RATINGS

The following table lists the required fuses:

Fuses	Nominal Mains Voltage	Rating	Case Size	Recommended Replacement Part	
				Littelfuse Part Number	Digi-Key Stock Number
#1, #2 (AC)	100-240V	0.5A, 250V, Time-Delay	5×20 mm	0218.500HXP	F2416-ND
#3 (DC)	N/A	1.6A, 250V, Time-Delay	5×20 mm	021801.6HXP	F2424-ND
#4 (DC)	N/A	0.8A, 250V, Time-Delay	5×20 mm	0218.800HXP	F2418-ND

The recommended fuse manufacturer is Littelfuse (<http://www.littelfuse.com>).

Replacement fuses may be easily obtained from Digi-Key (<http://www.digikey.com>) and other distributors.

FRONT PANEL CONTROLS

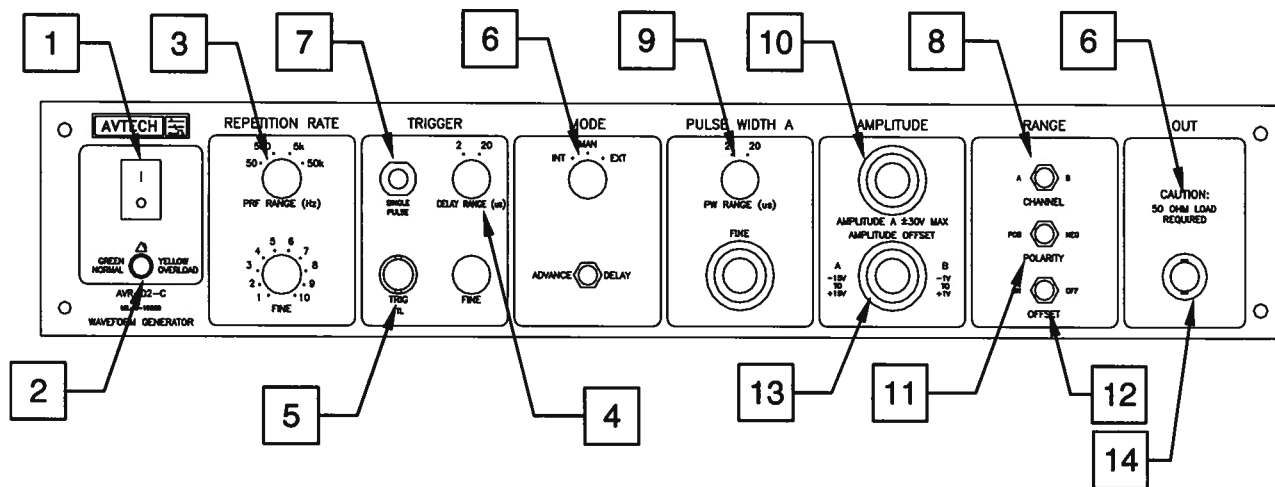

1. **POWER Switch.** This is the main power switch. When turning the instrument on, there may be a delay of several seconds before the instrument appears to respond.
2. **OVERLOAD Indicator.** When the instrument is powered, this indicator is normally green, indicating normal operation. If this indicator is yellow, an internal automatic overload protection circuit has been tripped. If the unit is overloaded (by operating at an exceedingly high duty cycle or by operating into a very low impedance), the protective circuit will disable the output of the instrument and turn the indicator light yellow. The light will stay yellow (i.e. output disabled) for about 5 seconds after which the instrument will attempt to re-enable the output (i.e. light green) for about 1 second. If the overload condition persists, the output will be disabled again (i.e. light yellow) for another 5 seconds. If the overload condition has been removed, the instrument will resume normal operation.

This overload indicator may flash yellow briefly at start-up. This is not a cause for concern.

Note that the output stage will safely withstand a short-circuited load condition.

3. **REPETITION RATE Controls.** When triggering internally, the range switch sets the pulse repetition frequency of the internal oscillator to one of four ranges:

RANGE 1	5 Hz - 50 Hz
RANGE 2	50 Hz - 500 Hz
RANGE 3	500 Hz - 5 kHz
RANGE 4	5 kHz - 50 kHz

The "FINE" knob varies the frequency within each range.

4. DELAY Control. Controls the relative delay between the reference output pulse provided at the TRIG output (5) and the main output (14). This delay is variable over the range of 0.2 to 20 us. The TRIG output precedes the main output when the ADVANCE-DELAY switch is in the ADVANCE position and lags when the switch is in the DELAY position.
5. TRIG Connector. When the MODE switch (item 6) is set to the “EXT” position, a TTL-level pulse applied to this connector will trigger the instrument. The instrument triggers on the rising edge of this input. The input impedance of this input is 1 k Ω . (Depending on the length of cable attached to this input, and the source driving it, it may be desirable to add a coaxial 50 Ohm terminator to this input to provide a proper transmission line termination. The Pasternack (www.pasternack.com) PE6008-50 BNC feed-thru 50 Ohm terminator is suggested for this purpose.)

When the MODE switch (item 6) is set to the “INT” position, this connector is used as an output that generates a 200 ns wide TTL-level pulse for each trigger event. This output can be used to trigger an oscilloscope, or other test equipment. The separation between the main output pulse and the TRIG output pulse is controlled by the DELAY controls and the ADVANCE/DELAY switch. For this output to operate correctly, the delay setting must be less than the period.

6. INT/MAN/EXT A/EXT B Mode Switch. With this switch in the INT position, the repetition rate of the unit is controlled by an internal oscillator, which in turn is controlled by the REPETITION RATE controls.

With the switch in the EXT position, the unit requires a 50 ns (or wider) TTL level pulse applied at the TRIG input in order to trigger the output stages.

For a single pulse output, the switch should be in the “MAN” position and then push the SINGLE PULSE pushbutton (10).

7. SINGLE PULSE Pushbutton. When the INT/MAN/EXT A/EXT B switch is in the “MAN” position, the instrument can be triggered by pressing this pushbutton. A single pulse is generated for each button press.
8. A/B CHANNEL Switch. This switch determines which channel (A or B) is provided on the main output connector (item 14).
9. PULSE WIDTH A Controls. This switch and ten-turn dial sets the pulse width of Channel A. (The pulse width of Channel B is not adjustable). The marked value of each switch position is the upper limit of the range, approximately. The vernier dial directly below the switch varies the delay within the set range.
10. AMPLITUDE A Control. This ten-turn locking dial varies the amplitude of Channel A. (The amplitude of Channel B is not adjustable).

11. POLARITY Switch. This switch determines the polarity (+ or -) of the output pulse. It is active for both Channels A and B.
12. OFFSET ON/OFF Switch. A DC offset (controlled by item 13) may be added to the output if this switch is set to "ON". Otherwise, this feature is disabled.
13. OFFSET Control. If the OFFSET ON/OFF switch (item 12) is set to "ON", this dial controls the DC offset added to the main output signal. When the CHANNEL A/B switch is set to "A", the offset can be varied over a -15V to +15V range. When the CHANNEL A/B switch is set to "B", the offset can be varied over a -1V to +1V range.
14. OUT Connector. This BNC output connector provides the main output signal. The load impedance must be 50 Ohms. If the test circuit specified by a particular standard does not have a 50 Ohm input impedance, you must add a shunt resistance at the circuit input such that the input impedance becomes 50 Ohms.

REAR PANEL CONTROLS

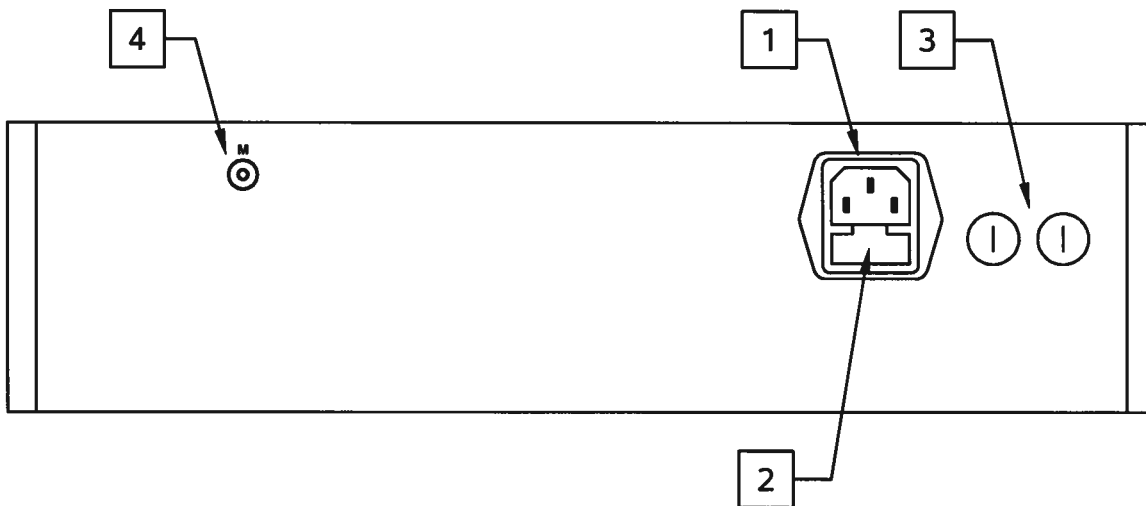

1. AC POWER INPUT. An IEC-320 C14 three-pronged recessed male socket is provided on the back panel for AC power connection to the instrument. One end of the detachable power cord that is supplied with the instrument plugs into this socket.
2. AC FUSE DRAWER. The two fuses that protect the AC input are located in this drawer. Please see the “FUSES” section of this manual for more information.
3. DC FUSES. These two fuses protect the internal DC power supplies. Please see the “FUSES” sections of this manual for more information.
4. M Connector. This monitor output provides an attenuated replica (± 11 , or -20.8 dB) of the voltage on the main output. The monitor output is designed to operate into a 50 Ohm load.

GENERAL INFORMATION

BASIC TEST ARRANGEMENT

The AVR-D2-C should be tested with a sampling oscilloscope with a bandwidth of at least 2 GHz to properly observe the high-speed waveform. A typical test arrangement is shown below:

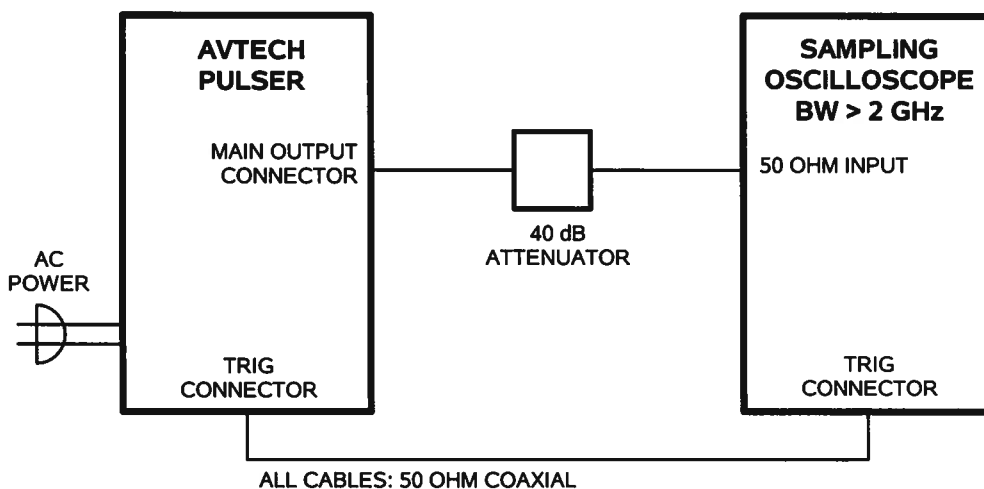

The attenuator is required to prevent damage to the sampling oscilloscope.

TYPICAL TEST SETUPS

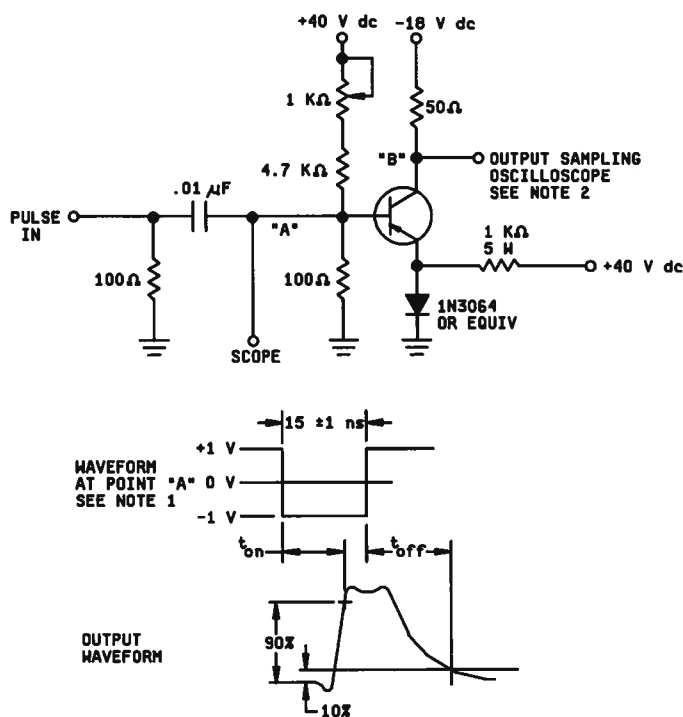

The figure above is taken from MIL-PRF-19500/177F, and is for testing the non-saturated switching time of PNP transistors.

The next figure is taken from MIL-PRF-19500/255V, and is for testing the saturated turn-on switching time of NPN transistors:

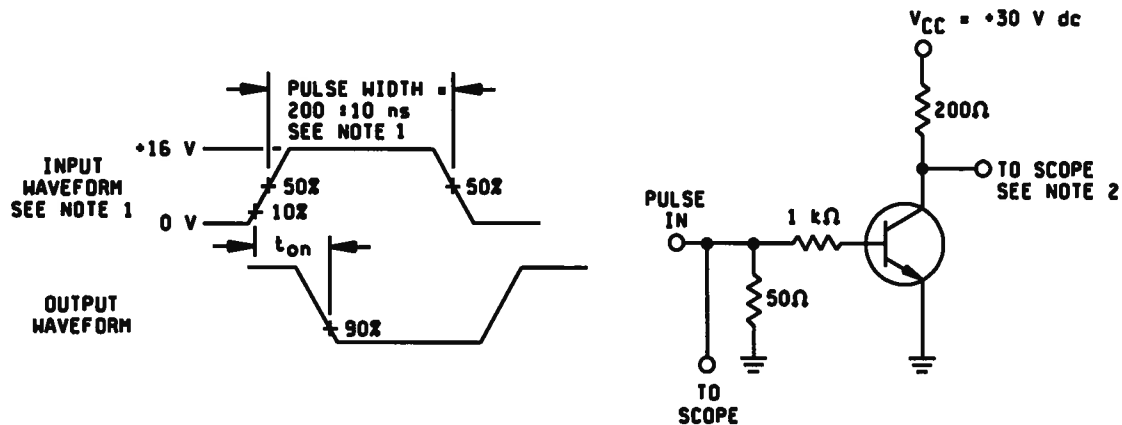

Both of the above circuits have 50 Ohm input impedance, so no additional shunt resistance is required. However, MIL-PRF-19500/255V also specifies a circuit for testing the saturated turn-off switching time of NPN transistors:

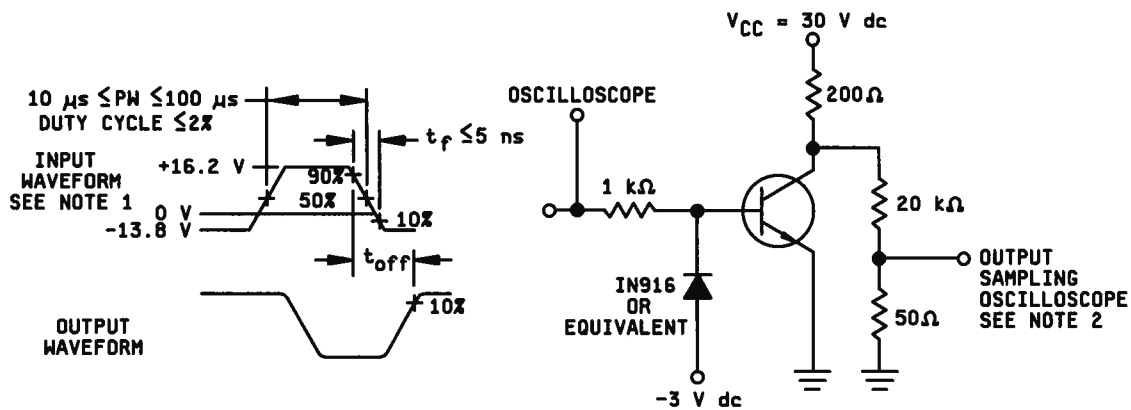

The input impedance of this circuit is 1 kilohm, so a 50 Ohm resistance (to ground) should be added at the input to this circuit, to avoid transmission line reflections.

Other circuits, specified in other MIL-PRF-19500 "slash sheets" can also be driven by the AVR-D2-C. The above circuits are only typical examples.

Avtech can provide test jigs (designed using proper high-speed construction techniques) to implement your required test circuitry. Contact Avtech (info@avtechpulse.com) with your test requirement!

MINIMIZING WAVEFORM DISTORTIONS

USE 50 OHM TRANSMISSION LINES AND LOADS

Connect the load to the pulse generator with 50 Ω transmission lines (e.g. RG-58 or RG-174 cable).

This instrument requires a 50 Ω load for proper operation. It will not properly drive a high-impedance load. The output stage will be damaged if it is operated into an open circuit (or any other high impedance). Failures due to improper output loading are not covered by the warranty.

USE LOW-INDUCTANCE LOADS

Lenz's Law predicts that for an inductive voltage spike will be generated when the current through an inductance changes. Specifically, $V_{\text{SPIKE}} = L \frac{dI_{\text{LOAD}}}{dt}$, where L is the inductance, I_{LOAD} is the load current change, and t is time. For this reason, it is important to keep any parasitic in the load low. This means keeping wiring short, and using low inductance components. In particular, wire-wound resistors should be avoided.

PREVENTING DAMAGE

The AVR-D2-C may fail if triggered at a PRF greater than 50 kHz.

This unit is designed to operate into a load impedance of 50 Ohms and the output stage will be damaged if it is operated into an open circuit (or any other high impedance). Failures due to improper output loading are not covered by the warranty.

The lifetime of the switching elements in the pulse generator module is proportional to the running time of the instrument. For this reason the prime power to the instrument should be turned off when the instrument is not in use.

MECHANICAL INFORMATION

TOP COVER REMOVAL

If necessary, the interior of the instrument may be accessed by removing the four Phillips screws on the top panel. With the four screws removed, the top cover may be slid back (and off).

 Always disconnect the power cord and allow the instrument to sit unpowered for 10 minutes before opening the instrument. This will allow any internal stored charge to discharge.

There are no user-adjustable internal circuits. For repairs other than fuse replacement, please contact Avtech (info@avtechpulse.com) to arrange for the instrument to be returned to the factory for repair. Service is to be performed solely by qualified service personnel.

 Caution: High voltages are present inside the instrument during normal operation. Do not operate the instrument with the cover removed.

RACK MOUNTING

A rack mounting kit is available. The -R5 rack mount kit may be installed after first removing the one Phillips screw on the side panel adjacent to the front handle.

ELECTROMAGNETIC INTERFERENCE

To prevent electromagnetic interference with other equipment, all used outputs should be connected to shielded loads using shielded coaxial cables. Unused outputs should be terminated with shielded coaxial terminators or with shielded coaxial dust caps, to prevent unintentional electromagnetic radiation. All cords and cables should be less than 3m in length.

MAINTENANCE

REGULAR MAINTENANCE

This instrument does not require any regular maintenance.

On occasion, one or more of the four rear-panel fuses may require replacement. All fuses can be accessed from the rear panel. See the “FUSES” section for details.

CLEANING

If desired, the interior of the instrument may be cleaned using compressed air to dislodge any accumulated dust. (See the “TOP COVER REMOVAL” section for instructions on accessing the interior.) No other cleaning is recommended.

WIRING DIAGRAMS

WIRING OF AC POWER, 1/2

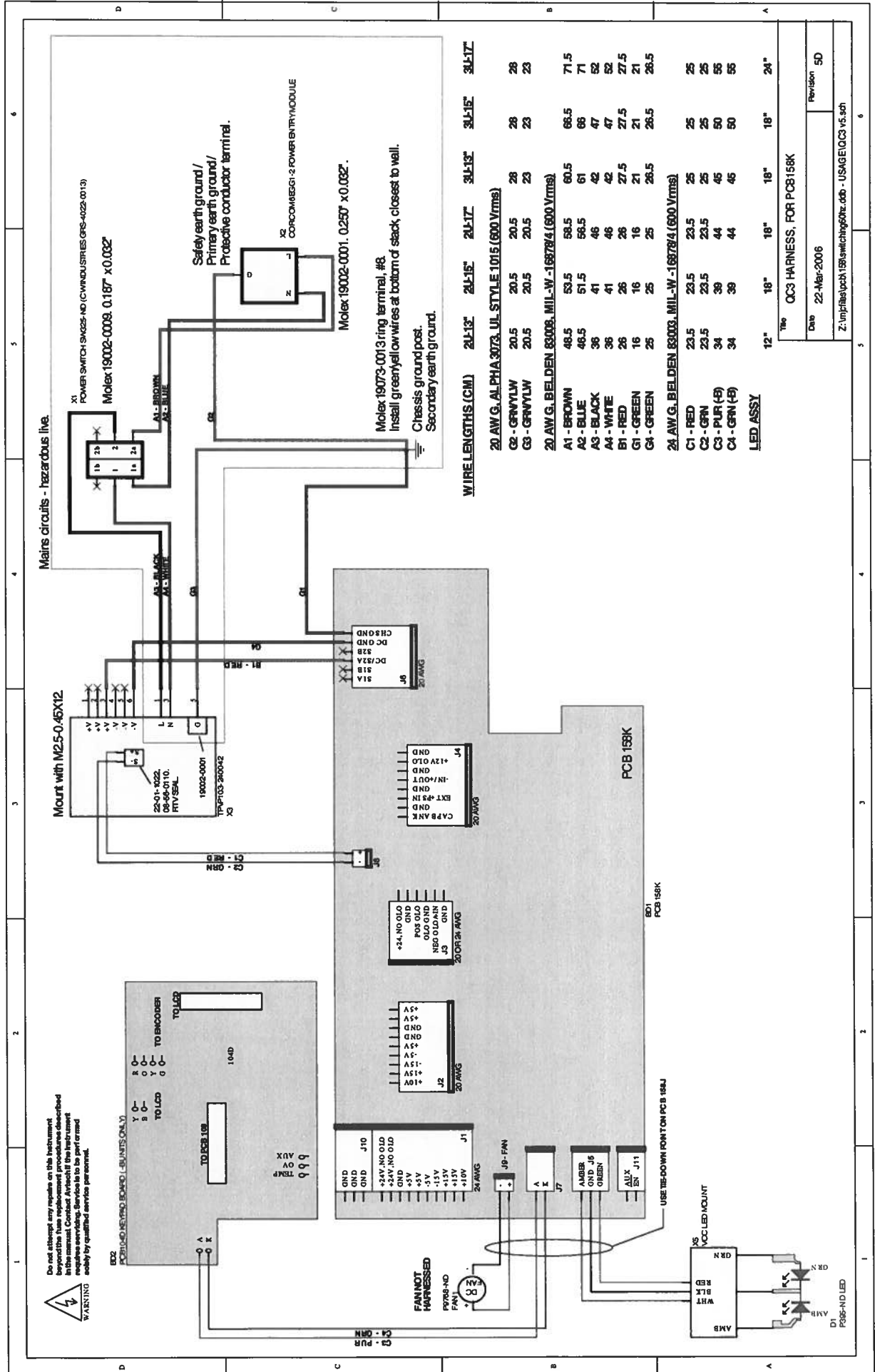

WIRE LENGTHS (CM)

Part	2U-13"	2U-15"	2U-17"	3U-13"	3U-15"	3U-17"
20 AW G. ALPHA 3073, UL STYLE 1015 (600 Vrms)						
G2 - GR/YLW	20.5	20.5	20.5	28	28	28
G3 - GR/YLW	20.5	20.5	20.5	23	23	23
20 AW G. BELDEN 83008, MIL-W-16878/4 (600 Vrms)						
A1 - BROWN	48.5	59.5	59.5	60.5	66.5	71.5
A2 - BLUE	46.5	51.5	56.5	61	66	71
A3 - BLACK	36	41	46	42	47	52
A4 - WHITE	36	41	46	42	47	52
B1 - RED	26	26	26	27.5	27.5	27.5
B2 - GREEN	16	16	16	21	21	21
B3 - GREEN	25	25	25	26.5	26.5	26.5
24 AW G. BELDEN 83003, MIL-W-16878/4 (600 Vrms)						
C1 - RED	23.5	23.5	23.5	25	25	25
C2 - GRN	23.5	23.5	23.5	25	25	25
C3 - PUR (+B)	34	39	44	45	50	55
C4 - GRN (+B)	34	39	44	45	50	55

LED ASSY

Part	12"	18"	18"	18"	18"	24"
LED ASSY						

WIRING OF AC POWER, 2/2

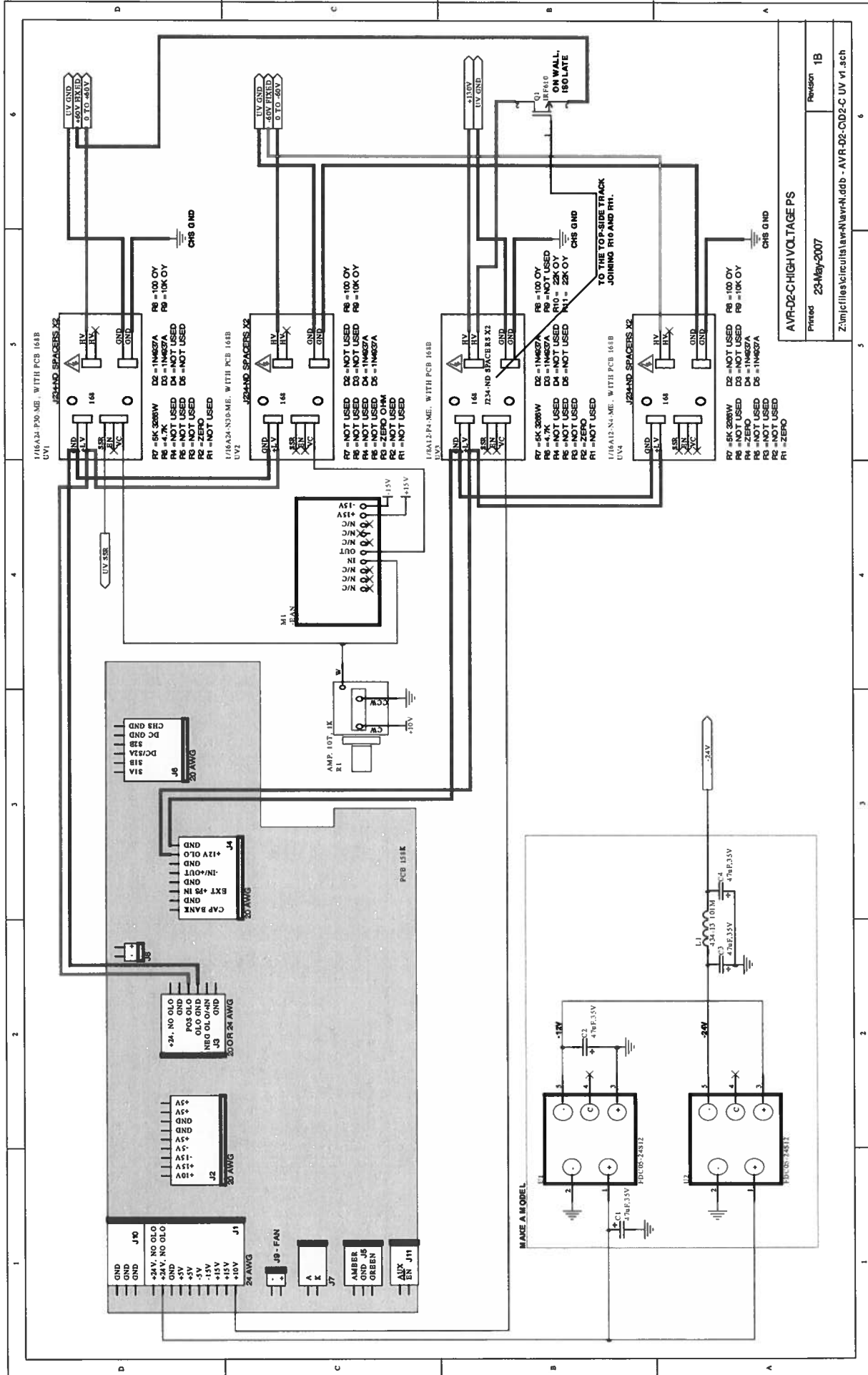

AVR-D2-HIGH VOLTAGE PS	
Printed	23-May-2007
Revision	1B
Z:\mpc\files\circuit\itla\nv1\avr-kddb - AVR-D2-CDE-C-UV v1.sch	

PCB 158K - LOW VOLTAGE POWER SUPPLY, 1/3

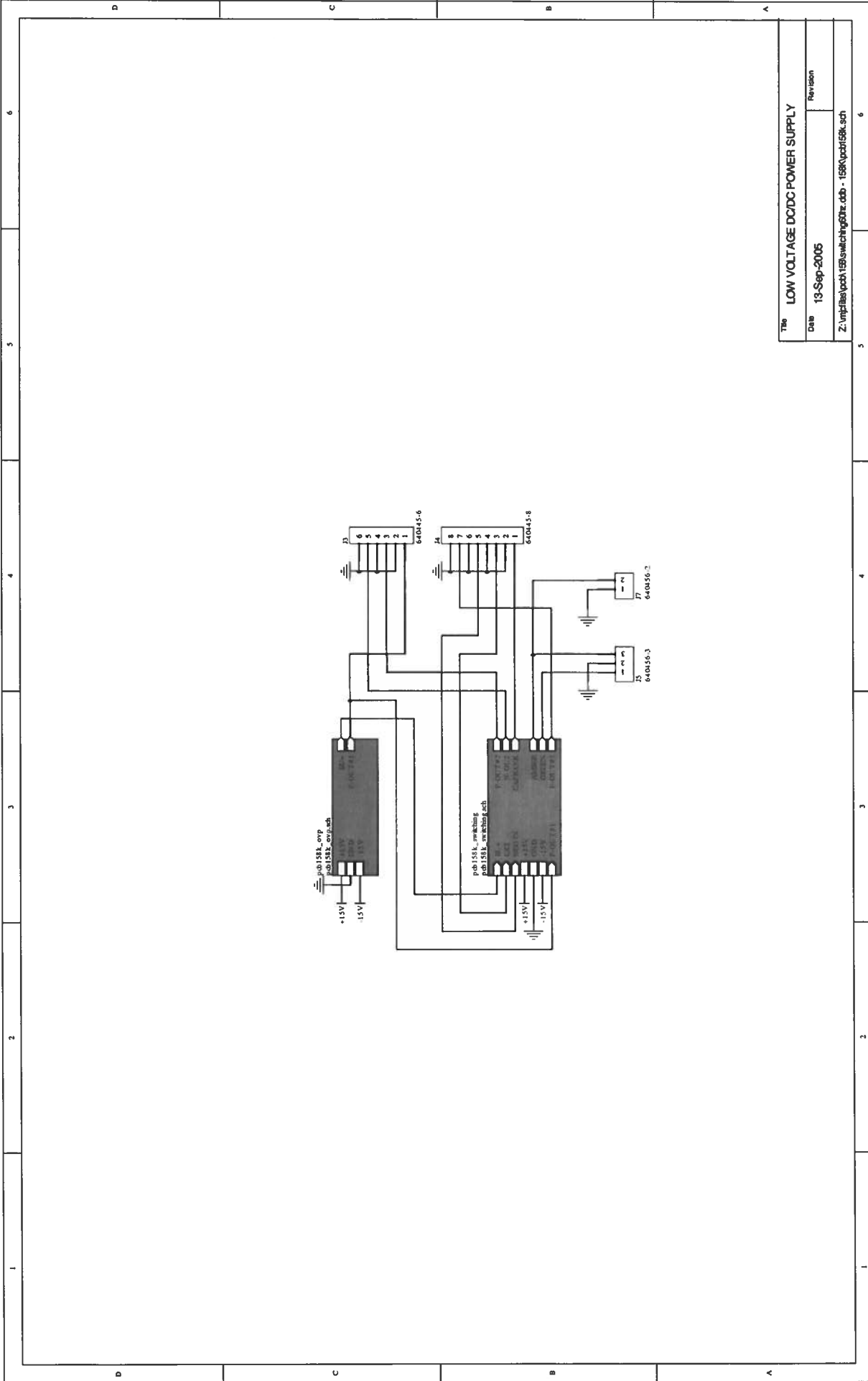

Title		LOW VOLTAGE DC/DC POWER SUPPLY
Date	13-Sep-2005	Revision
Z:\mpf\lib\pcb\158k\switching07hr.dtb - 158k\pcb\158k.sch		

PCB 158K - LOW VOLTAGE POWER SUPPLY, 2/3

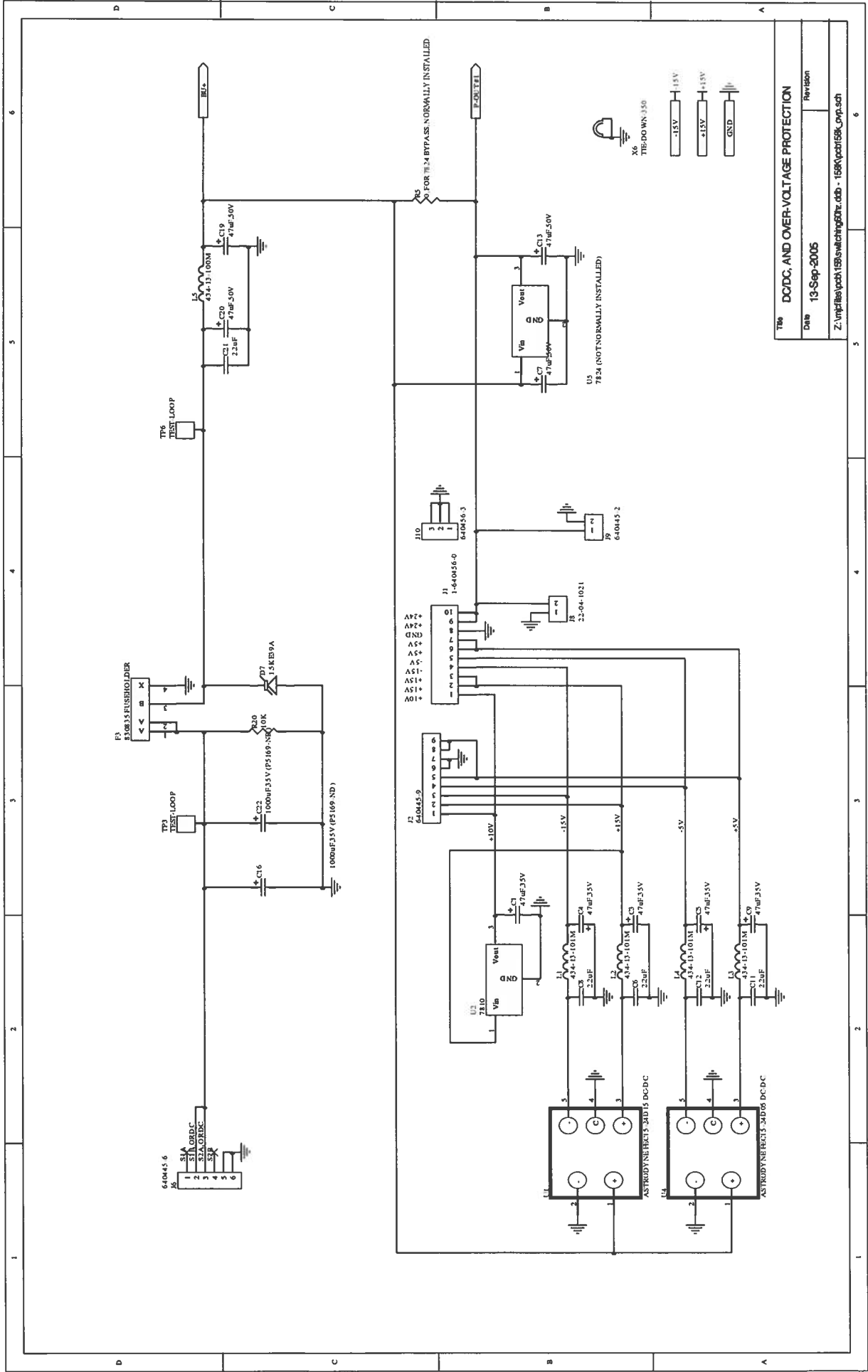

PCB 158K - LOW VOLTAGE POWER SUPPLY, 3/3

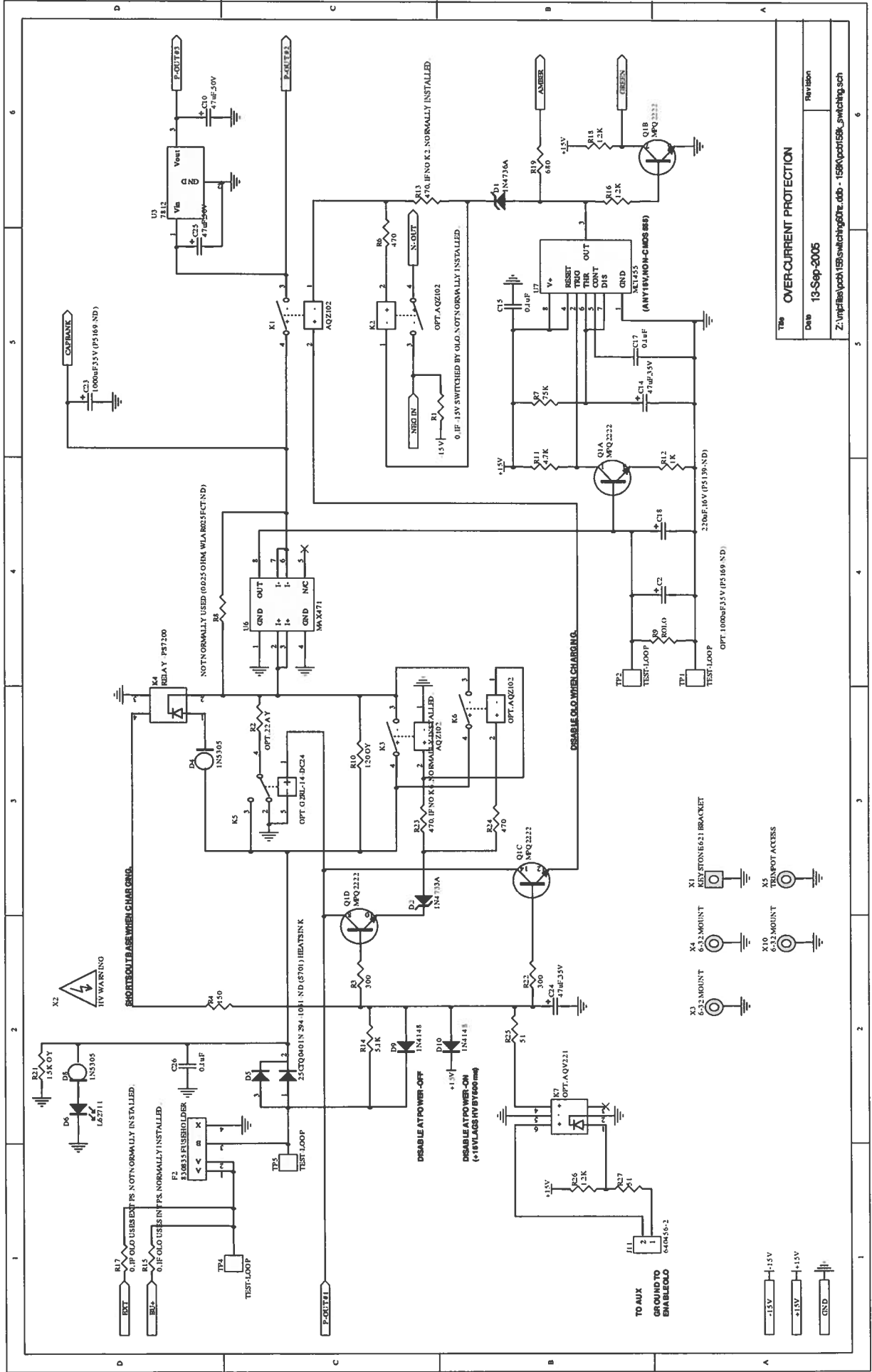

OVER-CURRENT PROTECTION	
Date	13-Sep-2005
Revision	

Z:\mp1\files\pck158\switching6tr.cdb - 158k\pck158k_switching.sch

PCB 168B - HIGH VOLTAGE DC POWER SUPPLY

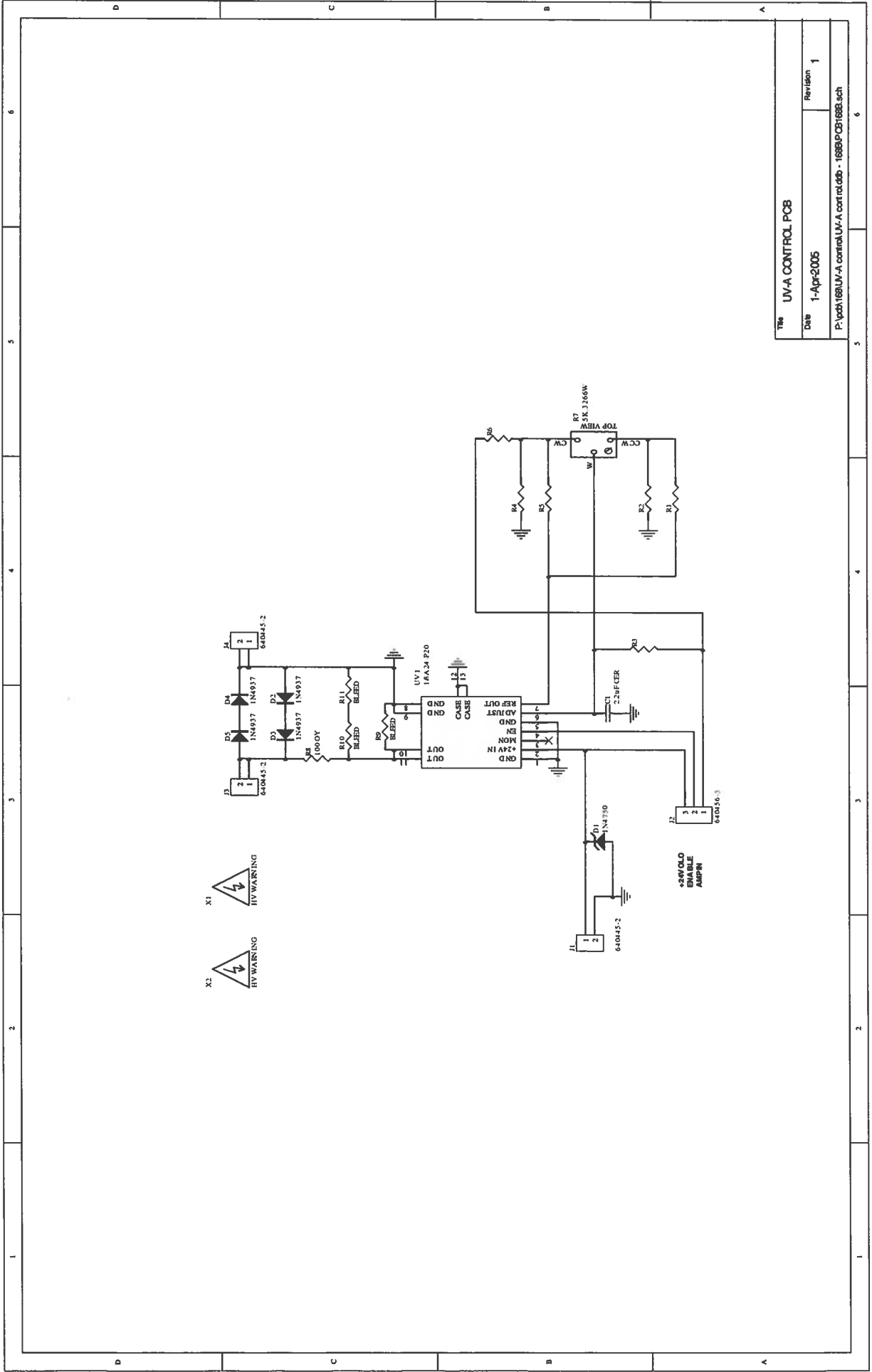

Title UV-A CONTROL PCB	
Date 1-Apr-2005	Revision 1
P:\pcb\168\UV-A control\UV-A control.dwg - 168B-PCB168B.sch	

PCB 152A - TIMING BOARD (1/2)

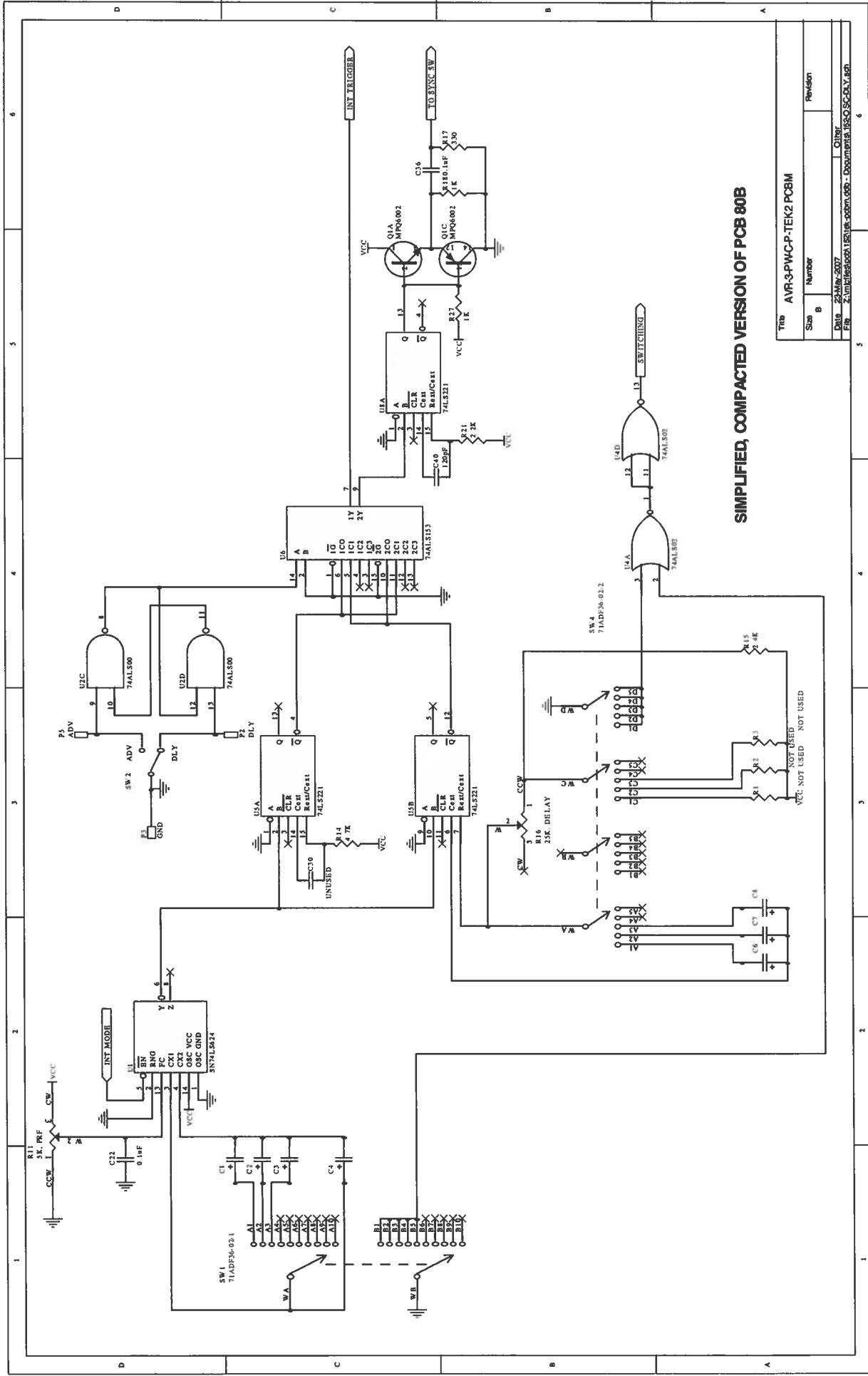

SIMPLIFIED, COMPACTED VERSION OF PCB 80B

Title		AVR-3-PWC-P-TEK2 PCB8M	
Sub	Number	Revision	
Date	22-May-2007	Other	
File	22m050601152a-152a-cobm.dwg	Documents	152A-SCO-DLY.dwg

PCB 152A - TIMING BOARD (2/2)

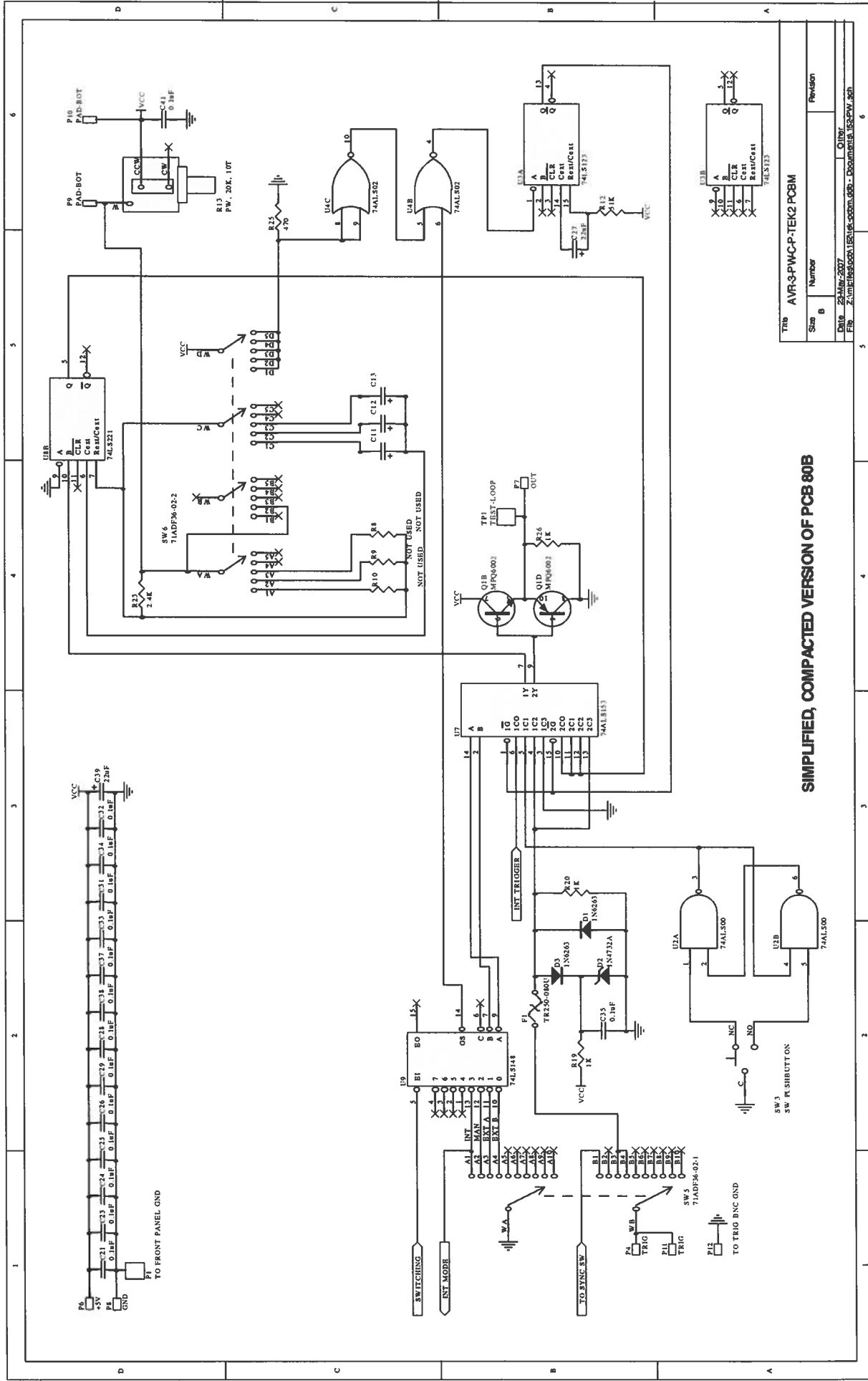

SIMPLIFIED, COMPACTED VERSION OF PCB 80B

TRN	AVR-3-PWC-P-TEK2 PCB		Revision
Size	B	Number	
Date	23-Mar-2007	Other	
File	Z:\mcl\test\pcb152a\pcb152a.dwg - Document 16, 152APW_2.dwg		

MAIN WIRING

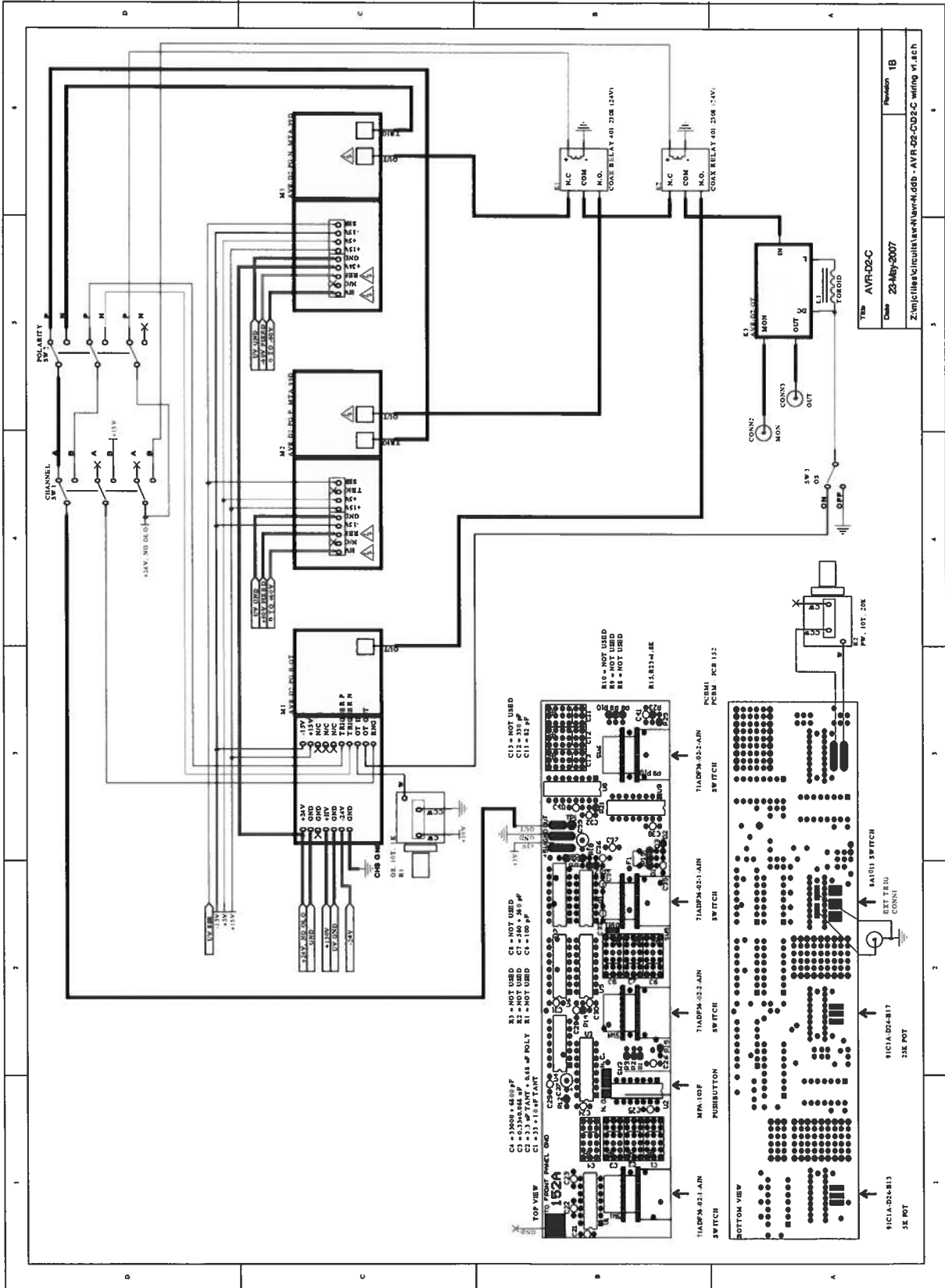

TERM	AVR-02-C
Date	28-May-2007
Revision	1B
Z:\proj\liss\sc\liss\liss\avr\liss - AVR-02-C-02-C wiring v1.sch	

May 23/07