



# AVTECH ELECTROSYSTEMS LTD.

NANOSECOND WAVEFORM ELECTRONICS  
SINCE 1975

□ P.O. BOX 265  
OGDENSBURG, NY  
U.S.A. 13669-0265  
TEL: (315) 472-5270  
FAX: (613) 226-2802

TEL: 1-800-265-6681  
FAX: 1-800-561-1970  
  
e-mail: [info@avtechpulse.com](mailto:info@avtechpulse.com)  
<http://www.avtechpulse.com>

□ P.O. BOX 5120 STN. F  
OTTAWA, ONTARIO  
CANADA K2C 3H4  
TEL: (613) 226-5772  
FAX: (613) 226-2802

## INSTRUCTIONS

### MODEL AVR-G3-8-C-TAG2 PULSE GENERATOR

S.N.:

## WARRANTY

Avtech Electrosystems Ltd. warrants products of its manufacture to be free from defects in material and workmanship under conditions of normal use. If, within one year after delivery to the original owner, and after prepaid return by the original owner, this Avtech product is found to be defective, Avtech shall at its option repair or replace said defective item. This warranty does not apply to units which have been disassembled, modified or subjected to conditions exceeding the applicable specifications or ratings. This warranty is the extent of the obligation assumed by Avtech with respect to this product and no other warranty or guarantee is either expressed or implied.

## TECHNICAL SUPPORT

Phone: 613-226-5772 or 1-800-265-6681

Fax: 613-226-2802 or 1-800-561-1970

E-mail: [info@avtechpulse.com](mailto:info@avtechpulse.com)

World Wide Web: <http://www.avtechpulse.com>

## TABLE OF CONTENTS

|   |    |
|---|----|
| WARRANTY .....                                | 2  |
| TABLE OF CONTENTS .....                       | 3  |
| FIG. 1: PULSE GENERATOR TEST ARRANGEMENT..... | 4  |
| FIG. 1A: BASIC OUTPUT WAVEFORM .....          | 5  |
| GENERAL OPERATING INSTRUCTIONS .....          | 6  |
| FIG. 2: FRONT PANEL CONTROLS .....            | 8  |
| FRONT PANEL CONTROLS .....                    | 9  |
| FIG. 3: BACK PANEL CONTROLS.....              | 11 |
| BACK PANEL CONTROLS.....                      | 12 |
| TOP COVER REMOVAL AND RACK MOUNTING.....      | 13 |
| POWER SUPPLY AND FUSE REPLACEMENT .....       | 14 |
| PRELIMINARY TEST PROCEDURE.....               | 16 |
| PERFORMANCE CHECK SHEET .....                 | 18 |

**FIG. 1: PULSE GENERATOR TEST ARRANGEMENT**

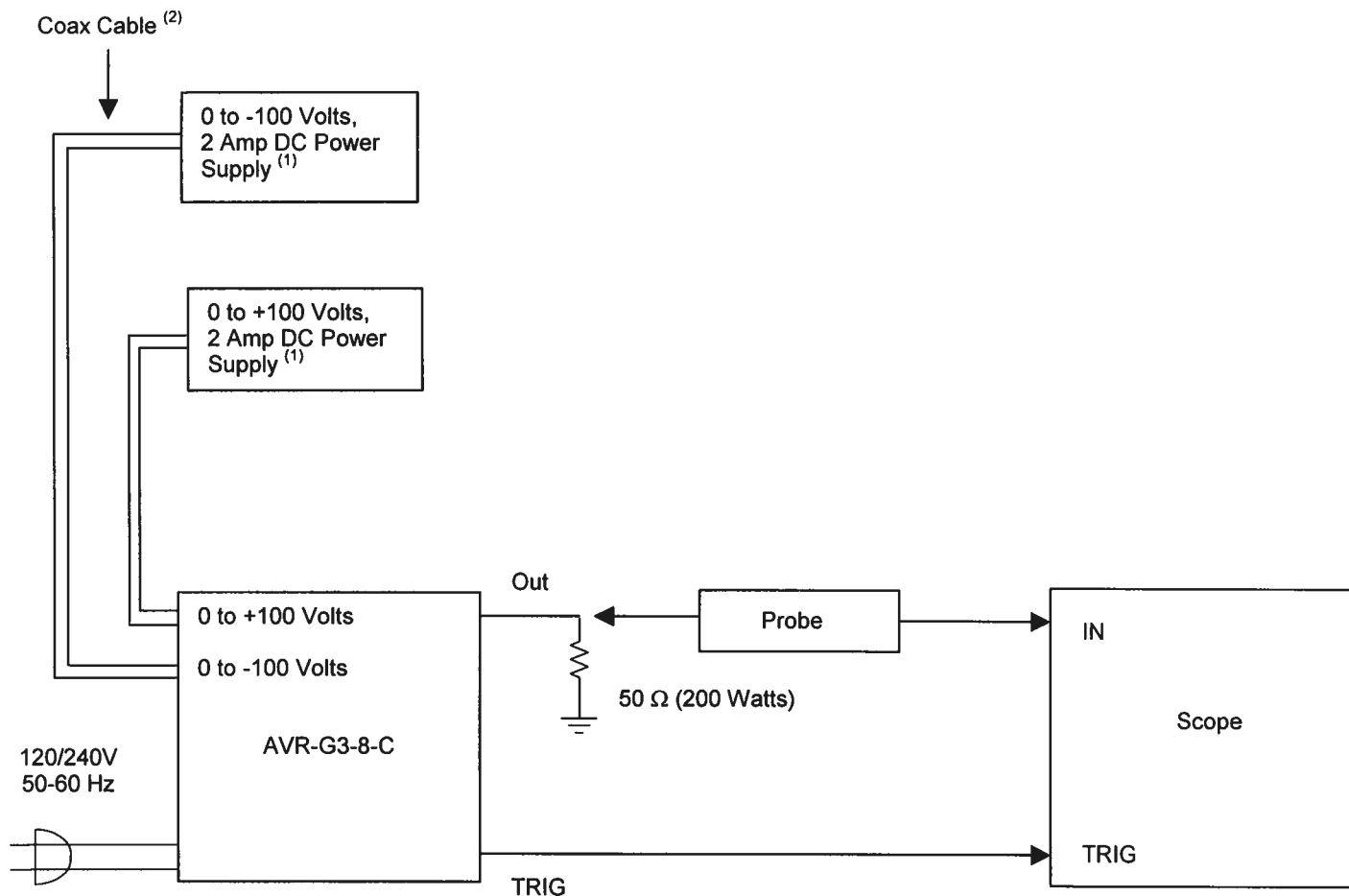

**NOTES:** 1) The following DC lab power supplies should be suitable:

- a) HP6555A  
HP6443B  
HP6655A
- b) Sorensen PCR150-2.5A
- c) Kopco JQE100-2.5M

2) Coax Cable:

Pomona Model 1450-C-60 (BNC male - double banana plug, 60")  
Available from Newark Electronics

FIG. 1A: BASIC OUTPUT WAVEFORM

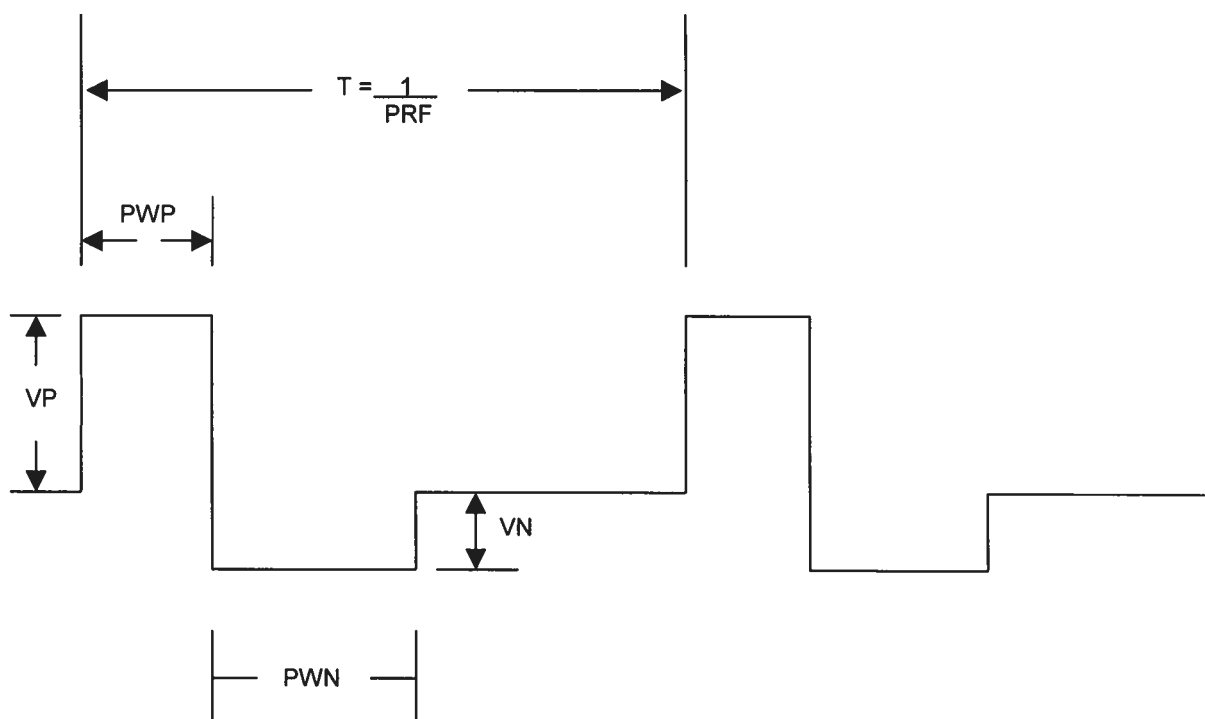

## GENERAL OPERATING INSTRUCTIONS

- 1) The Model AVR-G3-8-C Pulser, two 0 to 100 Volt, 2 Amp DC lab power supplies and the load should be configured as shown in Fig. 1.
- 2) The amplitude of the positive output pulse is about 1 Volt less than the setting on the positive lab power supply. The amplitude of the negative output pulse is about 1 Volt less than the negative power supply setting. Note that if the lab power supply settings exceed 100 Volts, an audible alarm will sound and triggering of the unit will stop (and the overload light will illuminate). The lab power supplies should be set to current limit at 2.0 Amps (to avoid pulser damage if the 80% duty cycle rating is accidentally exceeded).
- 3) **CAUTION:** This pulser is designed to output a bipolar waveform of the form shown in Fig. 1A. To avoid damaging the output stage, extreme care must be taken to ensure that the maximum duty cycle rating of 80% is never exceeded, i.e.  $PWP + PWN \leq 0.8 T$ .
- 4) The positive and negative output pulse widths are controlled by means of the two front panel ten-turn PW controls and by the PW RANGE controls. Note that the MODE switch must be in the INT position.

|         | PW min | PW max |
|---------|--------|--------|
| Range 1 | 25 us  | 250 us |
| Range 2 | 250 us | 2.5 ms |
| Range 3 | 2.5 ms | 25 ms  |

**CAUTION:** The PWP or PWN settings must never exceed 80% of the signal period.

- 5) The TRIG output channel provides TTL level signals. The TRIG output precedes the main output when the front panel ADVANCE-DELAY switch is in the ADVANCE position. The TRIG output lags the main output when the switch is in the DELAY position.

The DELAY control controls the relative delay between the reference output pulse provided at the TRIG output and the main output. This delay is variable over the range of 0.1 us to 100 us.

|         | MIN    | MAX    |
|---------|--------|--------|
| Range 1 | 0.1 us | 1.0 us |

|         |        |        |
|---------|--------|--------|
| Range 2 | 1.0 us | 10 us  |
| Range 3 | 10 us  | 100 us |

- 9) To obtain a stable output display the PRF control on the front panel should be set mid range. The front panel MODE switch should be in the INT position. The DELAY controls and the scope triggering controls are then adjusted to obtain a stable output. The scope may then be used to set the desired PRF by rotating the PRF controls.
- 10) An external clock may be used to control the output PRF of the AVR unit by setting the front panel MODE switch in the EXT position and applying a 50 ns (or wider) TTL level pulse to the TRIG BNC connector input.
- 11) For single pulse manual operation, set the front panel MODE switch in the MAN position and push the SINGLE PULSE button.
- 12) OVERLOAD PROTECTION: This model features overload functions:
  - a) Supply Voltages > 100 Volts: An audible alarm sounds, triggering stops and the front panel overload LED turns on.
  - b) Supply Voltages Reversed: No output pulse, no damage.
  - c) Load Resistance Less Than 50 Ohms: The output pulse triggering is inhibited if the peak output current exceeds 2.5 Amps.
  - d) Overheating: An audible alarm sounds, triggering stops and the front panel LED turns on if the output stage temperature exceeds +50°C.
- 10) The unit can be converted from 120 to 240V 50-60 Hz operation by adjusting the voltage selector card in the rear panel fused voltage selector cable connector assembly.
- 11) For further assistance:

Tel: 613-226-5772  
Fax: 613-226-2802  
Email: [info@avtechpulse.com](mailto:info@avtechpulse.com)

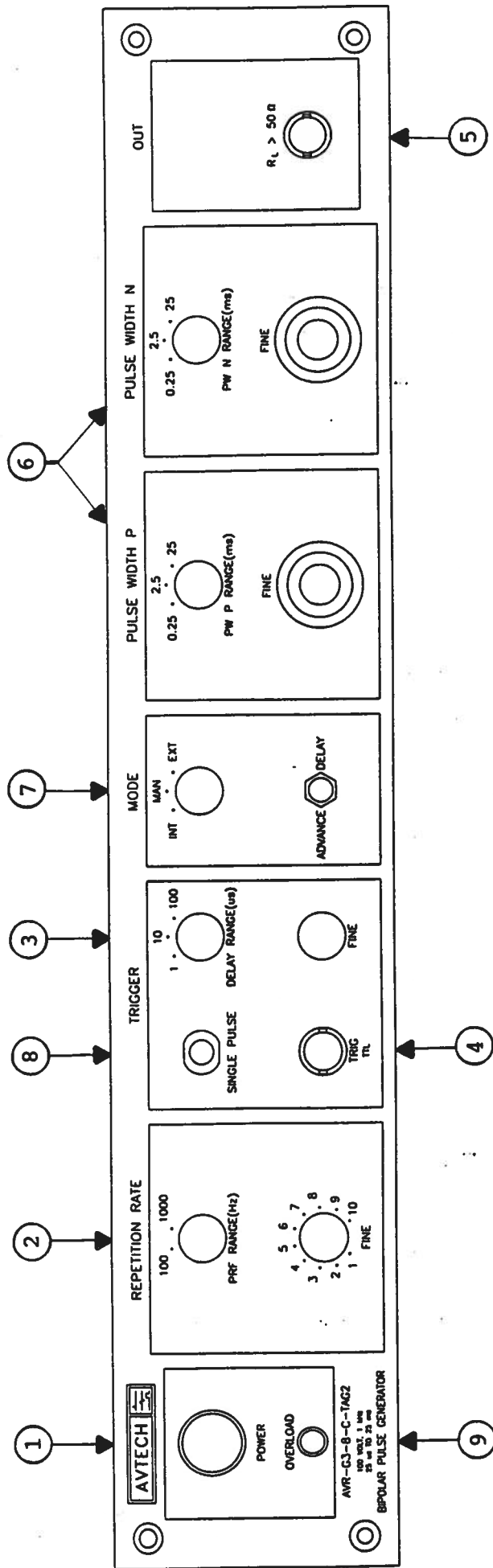

FIG. 2: FRONT PANEL CONTROLS



## FRONT PANEL CONTROLS

(1) ON-OFF Switch. Applies basic prime power to all stages.

(2) PRF Control. Varies PRF from 1 Hz to 1 kHz as follows:

|         |        |        |
|---------|--------|--------|
| Range 1 | 10 Hz  | 100 Hz |
| Range 2 | 100 Hz | 1 kHz  |

(3) DELAY Control. Controls the relative delay between the reference output pulse provided at the TRIG output (4) and the main output (5). This delay is variable over the range of 0.1 to about 100 us. Delay LEADS or LAGS depending on the position of the ADVANCE-DELAY switch.

|         | MIN    | MAX    |
|---------|--------|--------|
| Range 1 | 0.1 us | 1.0 us |
| Range 2 | 1.0 us | 10 us  |
| Range 3 | 10 us  | 100 us |

(4) TRIG Output. This output is used to trigger the scope time base. The output is a TTL level 100 ns (approx.) pulse capable of driving a fifty-Ohm load. This output precedes the output at (5) if the two-position ADVANCE-DELAY switch is in the ADVANCE position. This output follows the output at (5) if the switch is in the DELAY position. The delay range is variable from 0.1 us to 100 us. The external trigger signal is applied at this input when the EXT-INT toggle switch is in the EXT position.

(5) OUT Connector. BNC connector provides output to a 50-Ohm (or higher) load.

- (6) **PW Control.** Two ten-turn controls and two 3-position range switches which vary the output pulse widths from 25 us to 25 ms (when the MODE switch is in the INT position).

|         | PW min | PW max |
|---------|--------|--------|
| Range 1 | 25 us  | 250 us |
| Range 2 | 250 us | 2.5 ms |
| Range 3 | 2.5 ms | 25 ms  |

**CAUTION:** Never exceed the rated duty cycle of 80%, i.e.  
 $PWP + PWN \leq 0.8T$

- (7) **MODE.** With this switch in the INT position, the PRF of the AVR unit is controlled via an internal clock, which in turn is controlled by the PRF control. With the switch in the EXT position, the AVR unit requires a 50 ns (or wider) TTL level pulse applied at the TRIG input in order to trigger the output stages. In addition, in this mode, the scope time base must be triggered by the external trigger source. For single pulse operation, set the MODE switch in the MAN position.
- (8) **SINGLE PULSE.** For single pulse manual operation, set the front panel INT-EXT-MAN switch in the MAN position and push the SINGLE PULSE button.
- (9) **OVERLOAD PROTECTION:** This model features overload functions:
- Supply Voltages > 100 Volts:** An audible alarm sounds, triggering stops and the front panel overload LED turns on.
  - Supply Voltages Reversed:** No output pulse, no damage.
  - Load Resistance Less Than 50 Ohms:** The output pulse triggering is inhibited if the peak output current exceeds 2.5 Amps.
  - Overheating:** An audible alarm sounds, triggering stops and the front panel LED turns on if the output stage temperature exceeds +50°C.

FIG. 3: BACK PANEL CONTROLS

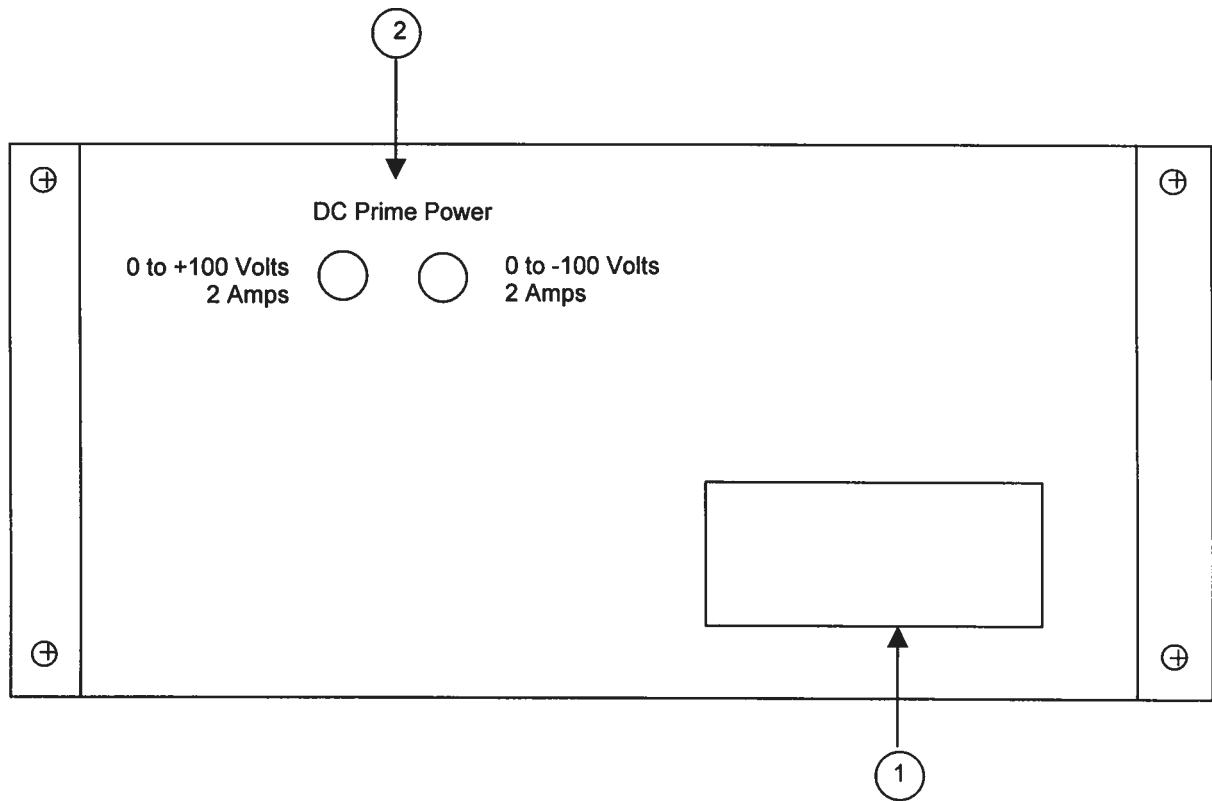

## BACK PANEL CONTROLS

- (1) FUSED CONNECTOR, VOLTAGE SELECTOR. The detachable power cord is connected at this point. In addition, the removable cord is adjusted to select the desired input operating voltage. The unit also contains the main power fuse.

For AC line voltages of 110-120V, the power selector card should be installed so that the "120" marking is visible from the rear of the instrument.

For AC line voltages of 220-240V, the power selector card should be installed so that the "240" marking is visible from the rear of the instrument.

If it is not set for the proper voltage, remove the fuse and then grasp the card with a pair of pliers and remove it. Rotate horizontally through 180 degrees. Reinstall the card and the correct fuse.

In the 120V setting, a 0.5A slow blow fuse is required. In the 240V setting, a 0.25A slow blow fuse is required.

- (2) DC PRIME POWER. A 0 to +100 VDC, 2 Amp lab power supply and a 0 to -100VDC, 2 Amp lab power supply are connected to these BNC connectors (see Fig. 1) The output pulse amplitudes are about 1 Volt less than the corresponding power supply amplitude settings. CAUTION: Current limit the power supply output to 2.0 Amps to avoid damaging the pulser if the 80% duty cycle rating is accidentally exceeded.

### TOP COVER REMOVAL AND RACK MOUNTING

- 1) The interior of the instrument may be accessed by removing the four Phillips screws on the top panel. With the four screws removed, the top cover may be slid back (and off).
- 2) The -R5 rack mount kit may be installed after first removing the one Phillips screw on the side panel adjacent to the front handle.

## POWER SUPPLY AND FUSE REPLACEMENT

This instrument has three fuses (plus one spare). One, which protects the AC input, is located in the rear-panel power entry module, as described in the "Rear Panel Controls" section of this manual. If the power appears to have failed, check the AC fuse first.

The other two fuses (plus one spare) are located on the internal DC power supply, as shown below:

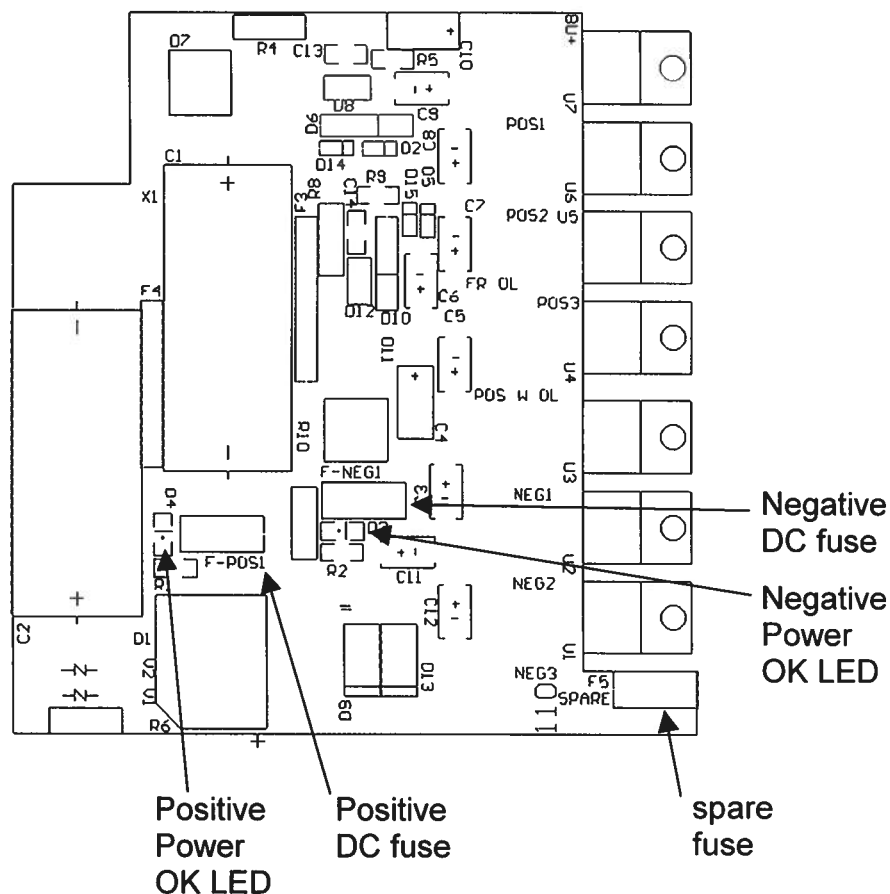

The spare fuse may be used to replace one of the other fuses, if required.

The three fuses on this circuit board are 0.5A slow-blow fuses, Littlefuse part number R452.500. (This fuse can be ordered from Digikey, [www.digikey.com](http://www.digikey.com). The Digikey part number is F1341CT-ND).

If you suspect that the DC fuses are blown, follow this procedure:

1. Remove the top cover, by removing the four Phillips screws on the top cover and then sliding the cover back and off.
2. Locate the two "Power OK" LEDs on the power supply circuit board, as illustrated above.
3. Turn on the instrument.
4. Observe the "Power OK" LEDs. If the fuses are not blown, the two LEDs will be lit (bright red). If one of the LEDs is not lit, the fuse next to it has blown.
5. Turn off the instrument.
6. If a fuse is blown, use needle-nose pliers to remove the blown fuse from its surface-mount holder.
7. Replace the fuse.

## PRELIMINARY TEST PROCEDURE

To gain familiarity with the pulser, it is recommended that the following "first time" test procedure be followed:

- 1) Configure the unit as shown in Fig. 1. Connect the low power 50-Ohm test load to the output.
- 2) Set the pulser controls as follows:

|                |         |
|----------------|---------|
| PRF Range:     | 100 Hz  |
| PRF Fine:      | Max CW  |
| Trigger Range: | 1 us    |
| Trigger Fire:  | Max CW  |
| Model:         | INT     |
| Advance/Delay: | ADVANCE |
| PWP Range:     | 0.25 ns |
| PWP Fine:      | Max CW  |
| PWN Range:     | 0.25 ns |
| PWN Fine:      | Max CW  |

Set the scope controls as follows:

|                   |              |
|-------------------|--------------|
| Scope Trigger:    | EXT          |
| Scope Vertical:   | 50 Volts/DIV |
| Scope Horizontal: | 50 us/DIV    |

Set the DC Power Supply controls as follows:

|            |         |
|------------|---------|
| Amplitude: | 0 Volts |
|------------|---------|

- 3) Apply 60 Hz power to the pulser and to the scope. The scope time base should be triggered. If not, then adjust the scope triggering controls.
- 4) Apply 60 Hz power to both DC power supplies.
- 5) Increase the positive DC supply to +50 Volts. A positive 50 Volts, 250 us pulse should appear on the screen.
- 6) Increase the negative DC supply to -50 Volts. A negative 50 Volts, 250 us pulse should appear immediately following the positive pulse.
- 7) Increase both amplitudes to 100 Volts and confirm that the scope displays a +100 Volt pulse followed by a -100 Volt pulse.



- 8) Change the time base to 2.0 ms/DIV. The scope should display two bipolar pulses separated by 10 ms.
- 9) For higher duty cycle testing, replace the low power test load with a 50-Ohm 200 Watt unit.
- 10) If any questions arise, please contact Avtech Electrosystems Ltd. at:  
Tel: 613-226-5772  
Fax: 613-226-2802  
Email: [info@avtechpulse.com](mailto:info@avtechpulse.com)

March 8/2001  
(ed. A)