



AVTECH ELECTROSYSTEMS LTD.

NANOSECOND WAVEFORM ELECTRONICS
SINCE 1975

P.O. BOX 265
OGDENSBURG, NY
U.S.A. 13669-0265
TEL: (315) 472-5270
FAX: (613) 226-2802

TEL: 1-800-265-6681
FAX: 1-800-561-1970

e-mail: info@avtechpulse.com
<http://www.avtechpulse.com/>

BOX 5120, LCD MERIVALE
OTTAWA, ONTARIO
CANADA K2C 3H4
TEL: (613) 226-5772
FAX: (613) 226-2802

INSTRUCTIONS

MODEL AVRL-3-PS-BNA

HIGH SPEED PULSE GENERATOR WITH

0 TO -250 VOLTS AMPLITUDE

0 TO +100V OFFSET

SERIAL NUMBER: _____

WARRANTY

Avtech Electrosystems Ltd. warrants products of its manufacture to be free from defects in material and workmanship under conditions of normal use. If, within one year after delivery to the original owner, and after prepaid return by the original owner, this Avtech product is found to be defective, Avtech shall at its option repair or replace said defective item. This warranty does not apply to units which have been disassembled, modified or subjected to conditions exceeding the applicable specifications or ratings. This warranty is the extent of the obligation assumed by Avtech with respect to this product and no other warranty or guarantee is either expressed or implied.

TECHNICAL SUPPORT

Phone: 613-226-5772 or 1-800-265-6681

Fax: 613-226-2802 or 1-800-561-1970

E-mail: info@avtechpulse.com

World Wide Web: <http://www.avtechpulse.com>

TABLE OF CONTENTS

WARRANTY.....	2
TECHNICAL SUPPORT.....	2
TABLE OF CONTENTS.....	3
INTRODUCTION.....	5
ORIGINAL QUOTATION AND SPECIFICATIONS.....	6
EC DECLARATION OF CONFORMITY.....	8
INSTALLATION.....	9
VISUAL CHECK.....	9
POWER RATINGS.....	9
CONNECTION TO THE POWER SUPPLY.....	9
ENVIRONMENTAL CONDITIONS.....	10
FUSES.....	11
AC FUSE REPLACEMENT.....	11
DC FUSE REPLACEMENT.....	12
FUSE RATINGS.....	12
FRONT PANEL CONTROLS.....	13
REAR PANEL CONTROLS.....	15
GENERAL INFORMATION.....	16
BASIC TEST ARRANGEMENT.....	16
BASIC WAVEFORMS.....	16
LOAD IMPEDANCE.....	17
CABLING CONSIDERATIONS.....	17
PROTECTING YOUR INSTRUMENT.....	18
TURN OFF INSTRUMENT WHEN NOT IN USE.....	18
DO NOT EXCEED 1 MHz.....	18
USE A HIGH IMPEDANCE LOAD.....	18
MECHANICAL INFORMATION.....	19
TOP COVER REMOVAL.....	19
ELECTROMAGNETIC INTERFERENCE.....	19
MAINTENANCE.....	19
REGULAR MAINTENANCE.....	19

CLEANING.....19

WIRING DIAGRAMS.....20

WIRING OF AC POWER.....20

PCB 158F - LOW VOLTAGE DC POWER SUPPLY, 1/3.....21

PCB 158F - LOW VOLTAGE DC POWER SUPPLY, 2/3.....22

PCB 158F - LOW VOLTAGE DC POWER SUPPLY, 3/3.....23

PCB 168 - HIGH VOLTAGE DC POWER SUPPLY.....24

MAIN WIRING.....25

PERFORMANCE CHECK SHEET.....26

Manual Reference: T:\instructword\avr\AVRL-3-PS-BNA,edition1.sxw.
Last modified November 18, 2004.
Copyright © 2004 Avtech Electrosystems Ltd, All Rights Reserved.

INTRODUCTION

The AVRL-3-PS-BNA is a high performance instrument capable of generating amplitudes of up to -250V into 1 k Ω loads at repetition rates up to 1 MHz. A DC offset in the range of 0 to +100V may be added to the output. The output pulse width is variable from 20 to 200 ns. The rise time and fall times are less than 10 ns.

The output impedance (internal, in series with the output) is 50 Ohms, providing transmission line backmatching.

An external TTL pulse is required to trigger the instrument.

This instrument is intended for use in research and development laboratories.

ORIGINAL QUOTATION AND SPECIFICATIONS

Date: Wed, 22 Sep 2004 13:17:18 -0400
From: Avtech Sales
To: ddclark@lanl.gov
Subject: Avtech pulse generator quote (improved leadtime)

To: David Clark, Los Alamos Nat. Lab.
ddclark@lanl.gov
505-667-4147

David,

Following our telephone conversation, I am pleased to re-quote as follows (with improved leadtime):

Quote number: 12283

Model number: AVRL-3-PS-BNA

Description: High Voltage Pulser

Amplitude: 0 to -250V, adjustable by a front-panel ten-turn locking dial.

Offset: 0 to +100V, adjustable by a front-panel ten-turn locking dial.

Pulse width: 20 ns to 200 ns, adjustable by a front-panel one-turn dial.

Rise and fall times: < 10 ns

PRF: 0 to 1 MHz

Load impedance: > 1000 Ohms

Output impedance (internal, in series with output): 50 Ohms

Propagation delay: < 100 ns

Variable delay: not provided.

Trigger required: TTL, 50 ns or wider.

Connectors: BNC

Power: 100 - 240 V, 50 - 60 Hz.

Dimensions: 100 mm x 430 mm x 375 mm (3.9" x 17" x 14.8")

Other: similar to the standard AVRL-3-PS, described at
<http://www.avtechpulse.com/medium/avrl-3>

Price: \$___ US each, FOB destination.

Delivery: 6 weeks after receipt of order (rush).

Please call or email me if I can be of further assistance.

Regards,
Dr. Michael J. Chudobiak
Chief Engineer

--- Avtech Electrosystems Ltd. ----- since 1975 ---

PO Box 265	ph: 1-800-265-6681 or 613-226-5772	Box 5120,
Ogdensburg,	fax: 1-800-561-1970 or 613-226-2802	LCD Merivale
New York	email: info@avtechpulse.com	Ottawa, Ontario
USA 13669-0265	http://www.avtechpulse.com/	Canada K2C 3H4

Nanosecond Waveform Generators
for general purpose, R&D and OEM applications

Pulse Generators - Laser Diode Drivers - Pulse Amplifiers
Impulse Generators - Current Pulsers - Delay Generators - Splitters
Function Generators - Monocycle Generators - Frequency Dividers + more!

EC DECLARATION OF CONFORMITY

We

**Avtech Electrosystems Ltd.
P.O. Box 5120, LCD Merivale
Ottawa, Ontario
Canada K2C 3H4**

declare that this pulse generator meets the intent of Directive 89/336/EEC for Electromagnetic Compatibility. Compliance pertains to the following specifications as listed in the official Journal of the European Communities:

EN 50081-1 Emission

EN 50082-1 Immunity

and that this pulse generator meets the intent of the Low Voltage Directive 72/23/EEC as amended by 93/68/EEC. Compliance pertains to the following specifications as listed in the official Journal of the European Communities:

EN 61010-1:2001 Safety requirements for electrical equipment for measurement, control, and laboratory use



INSTALLATION

VISUAL CHECK

After unpacking the instrument mainframe and the transformer module, examine to ensure that they have not been damaged in shipment. Visually inspect all connectors, knobs, and handles. Confirm that a power cord and an instrumentation manual (this manual), are with the instrument. If the instrument has been damaged, file a claim immediately with the company that transported the instrument.

POWER RATINGS

This instrument is intended to operate from 100 - 240 V, 50 - 60 Hz.

The maximum power consumption is 57 Watts. Please see the "FUSES" section for information about the appropriate AC and DC fuses.

This instrument is an "Installation Category II" instrument, intended for operation from a normal single-phase supply.

CONNECTION TO THE POWER SUPPLY

An IEC-320 three-pronged recessed male socket is provided on the back panel for AC power connection to the instrument. One end of the detachable power cord that is supplied with the instrument plugs into this socket. The other end of the detachable power cord plugs into the local mains supply. Use only the cable supplied with the instrument. The mains supply must be earthed, and the cord used to connect the instrument to the mains supply must provide an earth connection. (The supplied cord does this.) The table below describes the power cord that is supplied with this instrument, depending on the destination region:

Destination Region	Description	Volex (http://www.volex.com) Part Number	Newark (http://www.newark.com) Stock Number
Continental Europe	European CEE 7/7 "Schuko" 230V, 50Hz	17850-C3-326	44F1841
United Kingdom	BS 1363, 230V, 50Hz	17962-C3-10	84F1025
Switzerland	SEV 1011, 230V, 50Hz	2102H-C3-10	93F2452
Israel	SI 32, 220V, 50Hz	2115H-C3-10	04F1115
North America, and all other areas	NEMA 5-15, 120V, 60 Hz	17250-B1-10	36F1255

ENVIRONMENTAL CONDITIONS

This instrument is intended for use under the following conditions:

- a) indoor use;
- b) altitude up to 2 000 m;
- c) temperature 5 °C to 40 °C;
- d) maximum relative humidity 80 % for temperatures up to 31 °C
decreasing linearly to 50 % relative humidity at 40 °C;
- e) Mains supply voltage fluctuations up to ± 10 % of the nominal voltage;
- f) no pollution or only dry, non-conductive pollution.

FUSES

This instrument contains four fuses. All are accessible from the rear-panel. Two protect the AC prime power input, and two protect the internal DC power supplies. The locations of the fuses on the rear panel are shown in the figure below:

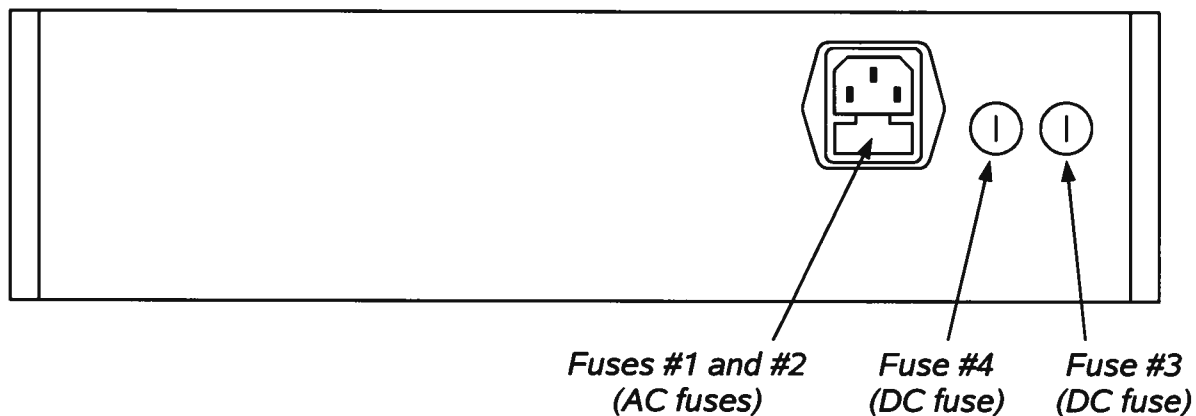

AC FUSE REPLACEMENT

To physically access the AC fuses, the power cord must be detached from the rear panel of the instrument. The fuse drawer may then be extracted using a small flat-head screwdriver, as shown below:

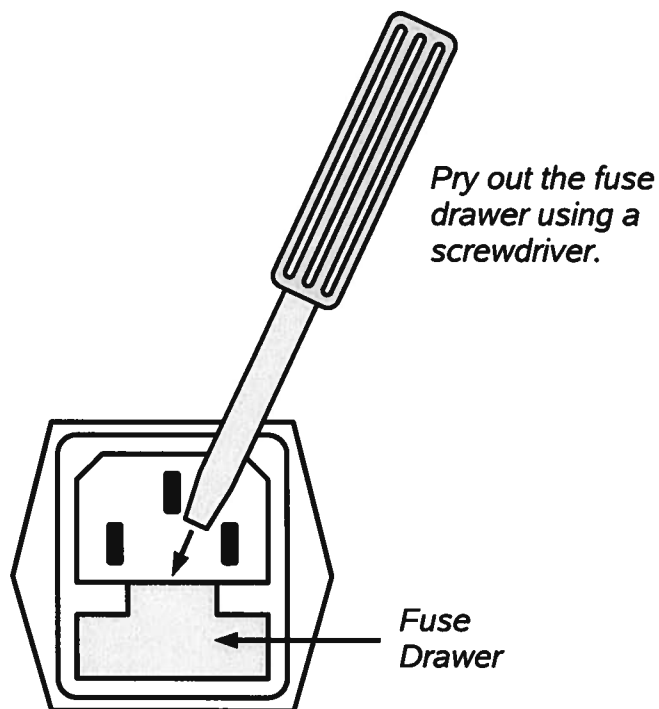

DC FUSE REPLACEMENT

The DC fuses may be replaced by inserting the tip of a flat-head screwdriver into the fuse holder slot, and rotating the slot counter-clockwise. The fuse and its carrier will then pop out.

FUSE RATINGS

The following table lists the required fuses:

Fuses	Nominal Mains Voltage	Rating	Case Size	Manufacturer's Part Number (Wickmann)	Distributor's Part Number (Digi-Key)
#1, #2 (AC)	100-240V	0.5A, 250V, Time-Delay	5×20 mm	1950500000	WK5041-ND
#3 (DC)	N/A	1.6A, 250V, Time-Delay	5×20 mm	1951160000	WK5053-ND
#4 (DC)	N/A	1.6A, 250V, Time-Delay	5×20 mm	1951160000	WK5053-ND

The fuse manufacturer is Wickmann (<http://www.wickmann.com/>).

Replacement fuses may be easily obtained from Digi-Key (<http://www.digikey.com/>) and other distributors.

FRONT PANEL CONTROLS

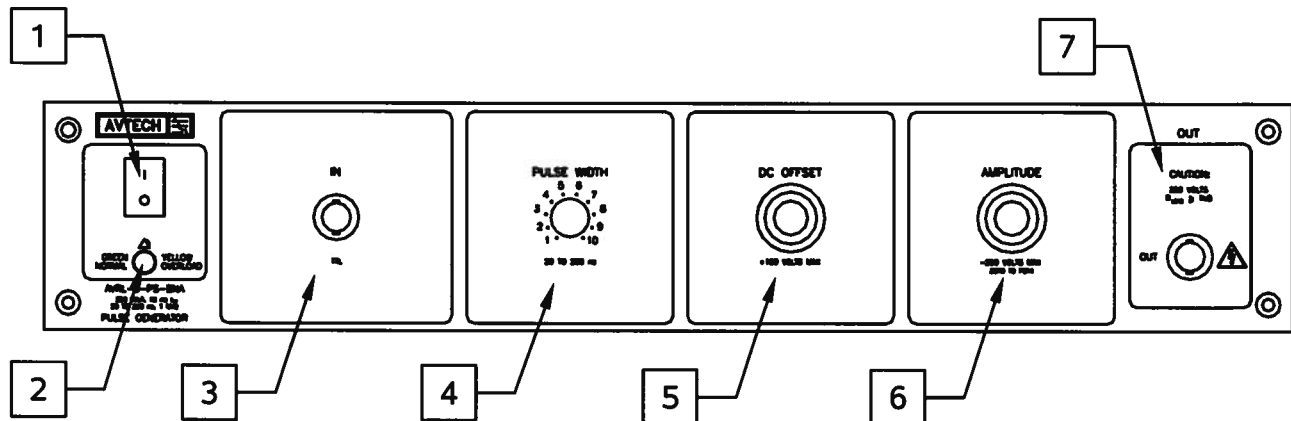

- 1) **POWER Switch**. This is the main power switch. When turning the instrument on, there may be a delay of several seconds before the instrument appears to respond.
- 2) **OVERLOAD Indicator**. When the instrument is powered, this indicator is normally green, indicating normal operation. If this indicator is yellow, an internal automatic overload protection circuit has been tripped. If the unit is overloaded (by operating at an exceedingly high duty cycle or by operating into a very low impedance), the protective circuit will disable the output of the instrument and turn the indicator light yellow. The light will stay yellow (i.e. output disabled) for about 5 seconds after which the instrument will attempt to re-enable the output (i.e. light green) for about 1 second. If the overload condition persists, the output will be disabled again (i.e. light yellow) for another 5 seconds. If the overload condition has been removed, the instrument will resume normal operation.

This overload indicator may flash yellow briefly at start-up. This is not a cause for concern.

- 3) **IN Connector**. The instrument is triggered by a TTL pulse applied to this connector. The pulse must be at least 50 ns wide. The input impedance of this input is 1 k Ω .

Depending on the length of cable attached to this input, and the source driving it, it may be desirable to add a coaxial 50 Ohm terminator to this input to provide a proper transmission line termination. The Pasternack (www.pasternack.com) PE6008-50 BNC feed-thru 50 Ohm terminator is suggested for this purpose. For systems using SMA connectors, the PE6026 SMA feed-thru 50 Ohm terminator is suggested.

- 4) **Pulse Width Control**. This dial controls the pulse width.
- 5) **DC Offset Control**. This dial controls the DC offset.
- 6) **Amplitude Control**. This dial controls the pulse amplitude.

- 7) **OUT Connector.** This connector provides the main output signal, into load impedances of 1 k Ω or higher. For extended instrument lifetime, the load impedance should be as high as possible (ideally open circuited, or at least $\gg 1$ k Ω).

The output should be left open-circuited (i.e., $R_L = \infty$) for operation at pulse repetition frequencies above 100 kHz.

The output impedance is 50 Ω , so the rise and fall times will degrade and the maximum pulse repetition frequency (PRF) will be reduced if cable lengths longer than 30 cm (1 foot) are used on the output, due to the cable capacitance.

 **Caution:** Voltages as high as 250V may be present on the center conductor of this output connector. Avoid touching this conductor. Connect to this connector using standard coaxial cable, to ensure that the center conductor is not exposed.

REAR PANEL CONTROLS

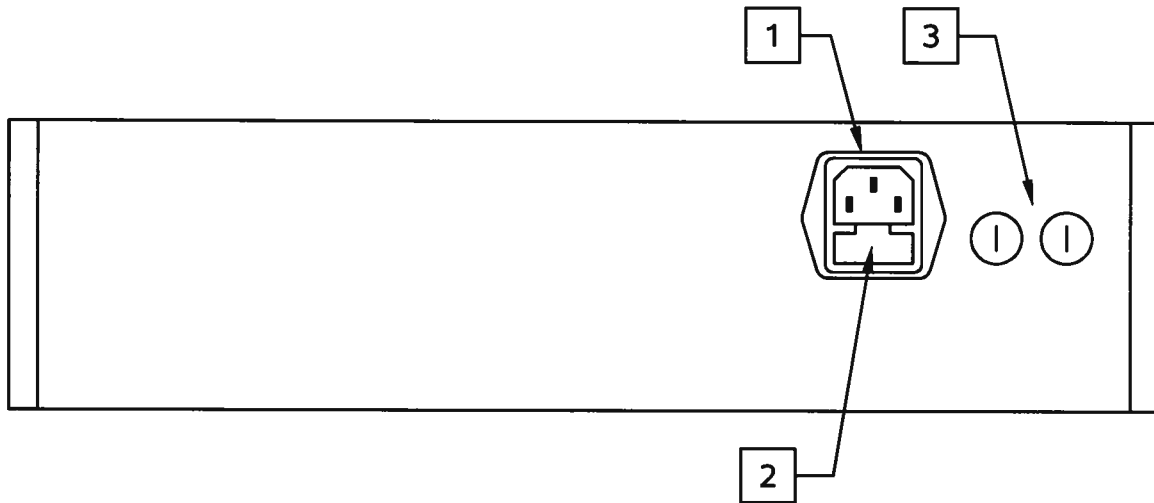

1. AC POWER INPUT. An IEC-320 C14 three-pronged recessed male socket is provided on the back panel for AC power connection to the instrument. One end of the detachable power cord that is supplied with the instrument plugs into this socket.
2. AC FUSE DRAWER. The two fuses that protect the AC input are located in this drawer. Please see the "FUSES" section of this manual for more information.
3. DC FUSES. These two fuses protect the internal DC power supplies. Please see the "FUSES" sections of this manual for more information.

GENERAL INFORMATION

BASIC TEST ARRANGEMENT

A typical test arrangement is shown below:

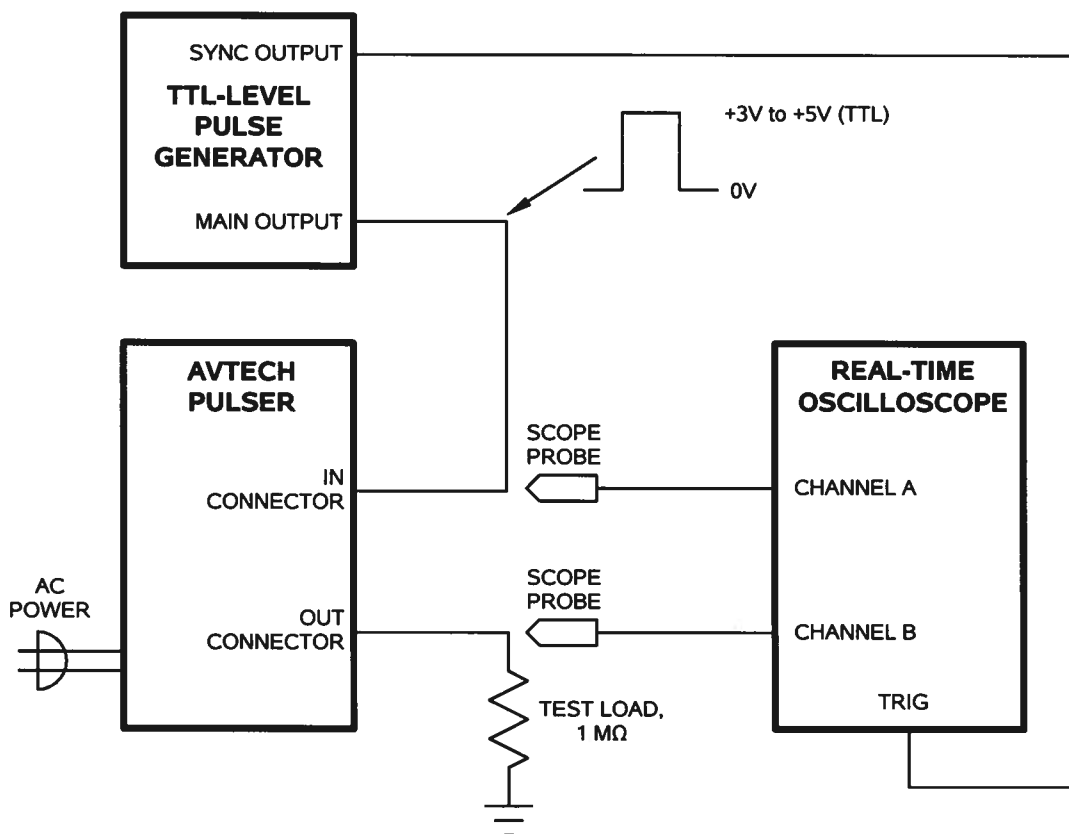

BASIC WAVEFORMS

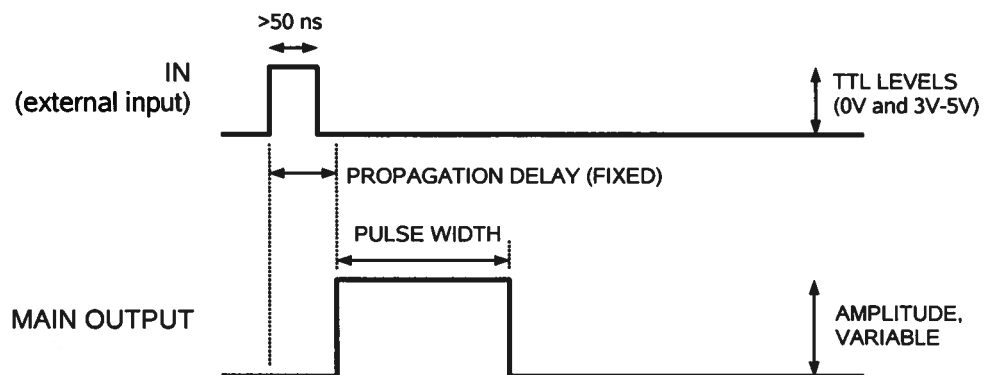

LOAD IMPEDANCE

 This unit was specifically designed to drive high impedance loads ($R_L \geq 1 \text{ k}\Omega$). The unit may fail if operated into low impedance loads (e.g. 50Ω). For extended instrument lifetime, the load impedance should be as high as possible (ideally open circuited, or at least $\gg 1 \text{ k}\Omega$).

The output should be left open-circuited (i.e., $R_L = \infty$) for operation at pulse repetition frequencies above 100 kHz.

CABLING CONSIDERATIONS

The rise and fall times are fixed at less than 10 ns. However, the output impedance is 50Ω , so the rise and fall times will degrade and the maximum pulse repetition frequency (PRF) will be reduced if cable lengths longer than 30 cm (1 foot) are used on the output, due to the cable capacitance.

The output is designed to drive loads of $1 \text{ k}\Omega$ or higher. Attaching a 50Ω load may damage the instrument. For extended instrument lifetime, the load impedance should be as high as possible (ideally open circuited, or at least $\gg 1 \text{ k}\Omega$).

PROTECTING YOUR INSTRUMENT

TURN OFF INSTRUMENT WHEN NOT IN USE

The lifetime of the switching elements in the pulse generator module is proportional to the running time of the instrument. For this reason the prime power to the instrument should be turned off when the instrument is not in use. In the case of failure, the switching elements are easily replaced following the procedure described in a following section.

DO NOT EXCEED 1 MHz

The output stage may be damaged if triggered by an external signal at a pulse repetition frequency greater than 1 MHz.

USE A HIGH IMPEDANCE LOAD

This unit is designed to operate into a load impedance of 1 k Ω or higher. The output may be damaged if load impedances lower than 1 k Ω are used. Never use a 50 Ohm load.

MECHANICAL INFORMATION

TOP COVER REMOVAL

If necessary, the interior of the instrument may be accessed by removing the four Phillips screws on the top panel. With the four screws removed, the top cover may be slid back (and off).

Always disconnect the power cord before opening the instrument.

There are no user-adjustable internal circuits. For repairs other than fuse replacement, please contact Avtech (info@avtechpulse.com) to arrange for the instrument to be returned to the factory for repair.

 Caution: High voltages are present inside the instrument during normal operation. Do not operate the instrument with the cover removed.

ELECTROMAGNETIC INTERFERENCE

To prevent electromagnetic interference with other equipment, all used outputs should be connected to shielded 50Ω loads using shielded 50Ω coaxial cables. Unused outputs should be terminated with shielded 50Ω coaxial terminators or with shielded coaxial dust caps, to prevent unintentional electromagnetic radiation. All cords and cables should be less than 3m in length.

MAINTENANCE

REGULAR MAINTENANCE

This instrument does not require any regular maintenance.

On occasion, one or more of the four rear-panel fuses may require replacement. All fuses can be accessed from the rear panel. See the “FUSES” section for details.

CLEANING

If desired, the interior of the instrument may be cleaned using compressed air to dislodge any accumulated dust. (See the “TOP COVER REMOVAL” section for instructions on accessing the interior.) No other cleaning is recommended.

WIRING DIAGRAMS

WIRING OF AC POWER

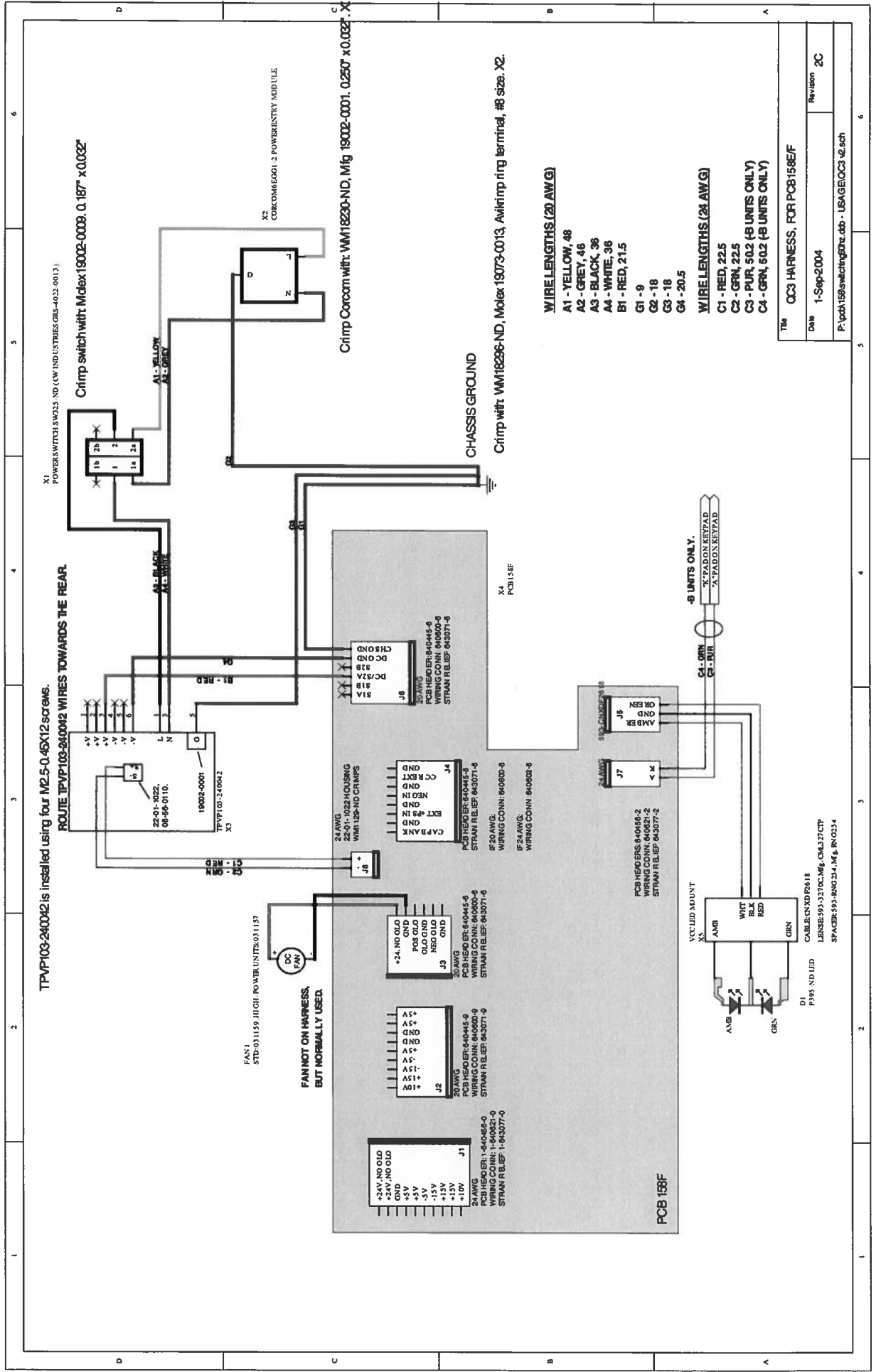

PCB 158F - LOW VOLTAGE DC POWER SUPPLY, 1/3

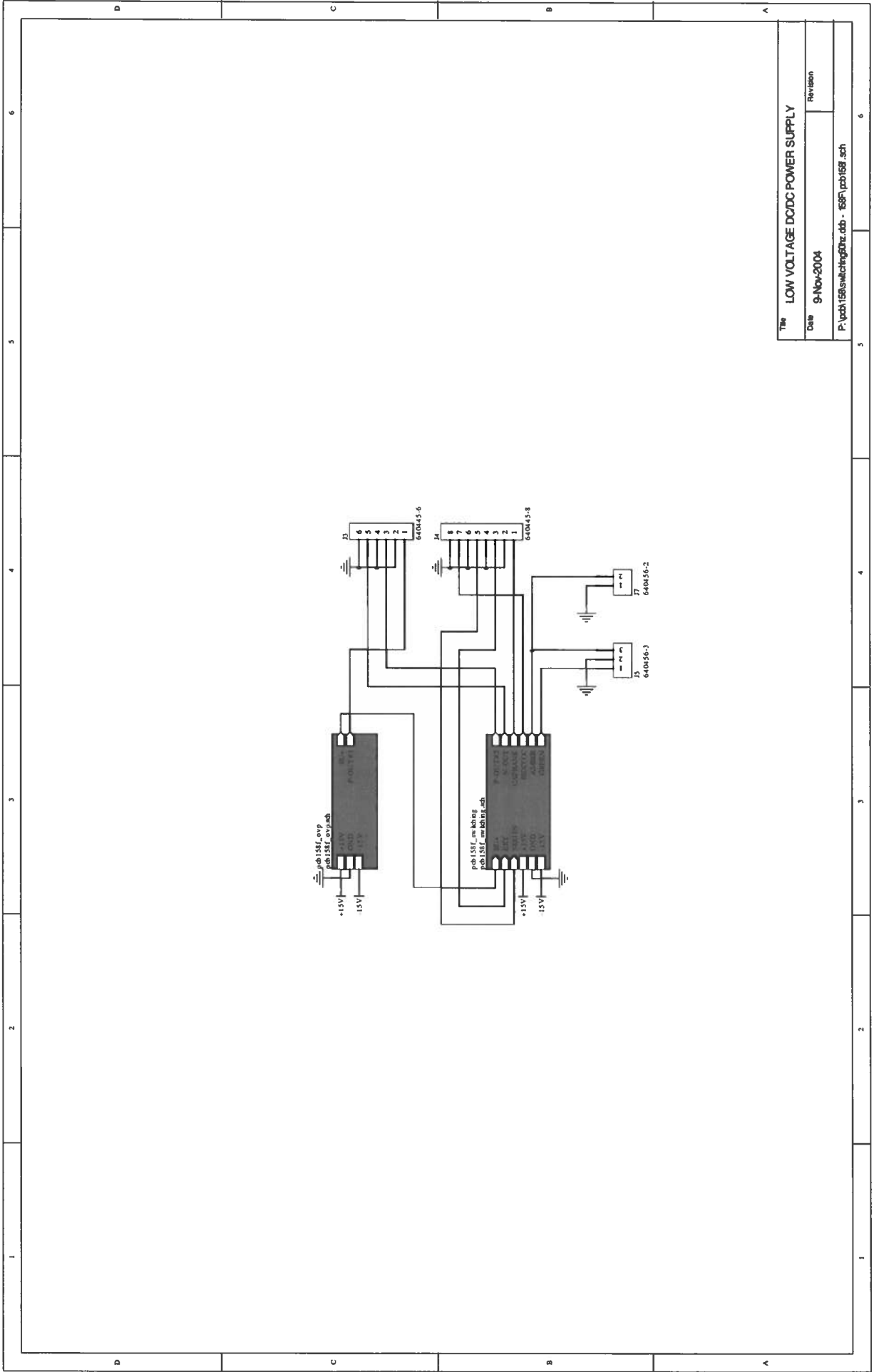

Title: LOW VOLTAGE DC/DC POWER SUPPLY

Date: 9-Nov-2004

Revision

P:\pcb\158\switching50tr.dcb - 158f\pcb158f.sch

PCB 158F - LOW VOLTAGE DC POWER SUPPLY, 2/3

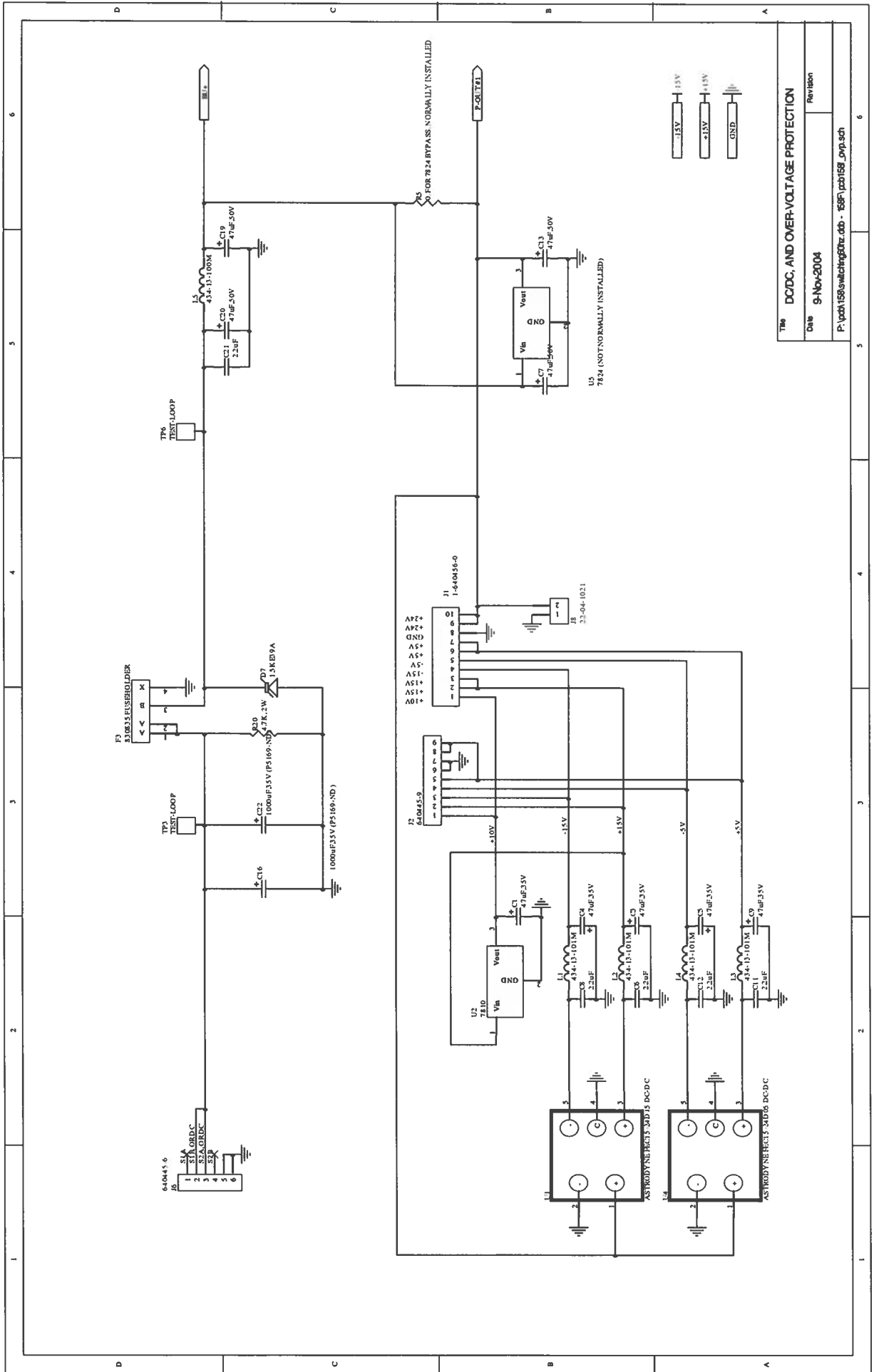

Title	DC/DC, AND OVER-VOLTAGE PROTECTION
Date	9-Nov-2004
Revision	
P:\pcb158\switching\trc.dcb - 158f.pcb158_0v0.sch	

PCB 158F - LOW VOLTAGE DC POWER SUPPLY, 3/3

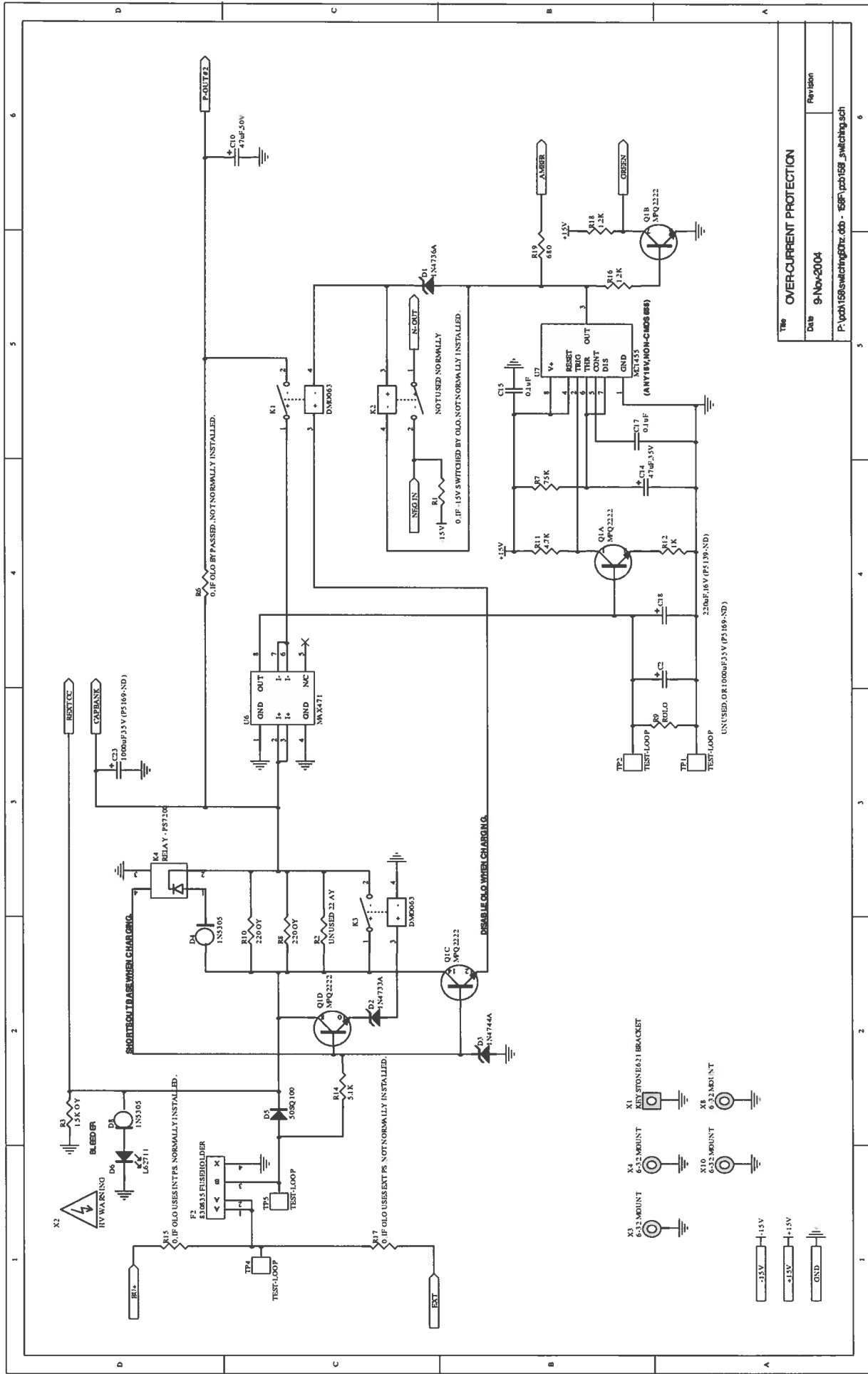

The OVERCURRENT PROTECTION	
DWG 9-Nov-2004	Revision
P:\pcb158\switching04z.cad - 158f\pcb158_switching.sch	

- X1 6-32 MOUNT
- X2 6-32 MOUNT
- X3 KEYSTONE 6.31 BRACKET
- X4 6-32 MOUNT
- X5 6-32 MOUNT
- X6 6-32 MOUNT
- X7 6-32 MOUNT
- X8 6-32 MOUNT
- X9 6-32 MOUNT
- X10 6-32 MOUNT
- X11 6-32 MOUNT
- X12 6-32 MOUNT
- X13 6-32 MOUNT
- X14 6-32 MOUNT
- X15 6-32 MOUNT
- X16 6-32 MOUNT
- X17 6-32 MOUNT
- X18 6-32 MOUNT
- X19 6-32 MOUNT
- X20 6-32 MOUNT
- X21 6-32 MOUNT
- X22 6-32 MOUNT
- X23 6-32 MOUNT
- X24 6-32 MOUNT
- X25 6-32 MOUNT
- X26 6-32 MOUNT
- X27 6-32 MOUNT
- X28 6-32 MOUNT
- X29 6-32 MOUNT
- X30 6-32 MOUNT
- X31 6-32 MOUNT
- X32 6-32 MOUNT
- X33 6-32 MOUNT
- X34 6-32 MOUNT
- X35 6-32 MOUNT
- X36 6-32 MOUNT
- X37 6-32 MOUNT
- X38 6-32 MOUNT
- X39 6-32 MOUNT
- X40 6-32 MOUNT
- X41 6-32 MOUNT
- X42 6-32 MOUNT
- X43 6-32 MOUNT
- X44 6-32 MOUNT
- X45 6-32 MOUNT
- X46 6-32 MOUNT
- X47 6-32 MOUNT
- X48 6-32 MOUNT
- X49 6-32 MOUNT
- X50 6-32 MOUNT
- X51 6-32 MOUNT
- X52 6-32 MOUNT
- X53 6-32 MOUNT
- X54 6-32 MOUNT
- X55 6-32 MOUNT
- X56 6-32 MOUNT
- X57 6-32 MOUNT
- X58 6-32 MOUNT
- X59 6-32 MOUNT
- X60 6-32 MOUNT
- X61 6-32 MOUNT
- X62 6-32 MOUNT
- X63 6-32 MOUNT
- X64 6-32 MOUNT
- X65 6-32 MOUNT
- X66 6-32 MOUNT
- X67 6-32 MOUNT
- X68 6-32 MOUNT
- X69 6-32 MOUNT
- X70 6-32 MOUNT
- X71 6-32 MOUNT
- X72 6-32 MOUNT
- X73 6-32 MOUNT
- X74 6-32 MOUNT
- X75 6-32 MOUNT
- X76 6-32 MOUNT
- X77 6-32 MOUNT
- X78 6-32 MOUNT
- X79 6-32 MOUNT
- X80 6-32 MOUNT
- X81 6-32 MOUNT
- X82 6-32 MOUNT
- X83 6-32 MOUNT
- X84 6-32 MOUNT
- X85 6-32 MOUNT
- X86 6-32 MOUNT
- X87 6-32 MOUNT
- X88 6-32 MOUNT
- X89 6-32 MOUNT
- X90 6-32 MOUNT
- X91 6-32 MOUNT
- X92 6-32 MOUNT
- X93 6-32 MOUNT
- X94 6-32 MOUNT
- X95 6-32 MOUNT
- X96 6-32 MOUNT
- X97 6-32 MOUNT
- X98 6-32 MOUNT
- X99 6-32 MOUNT
- X100 6-32 MOUNT



PCB 168 - HIGH VOLTAGE DC POWER SUPPLY

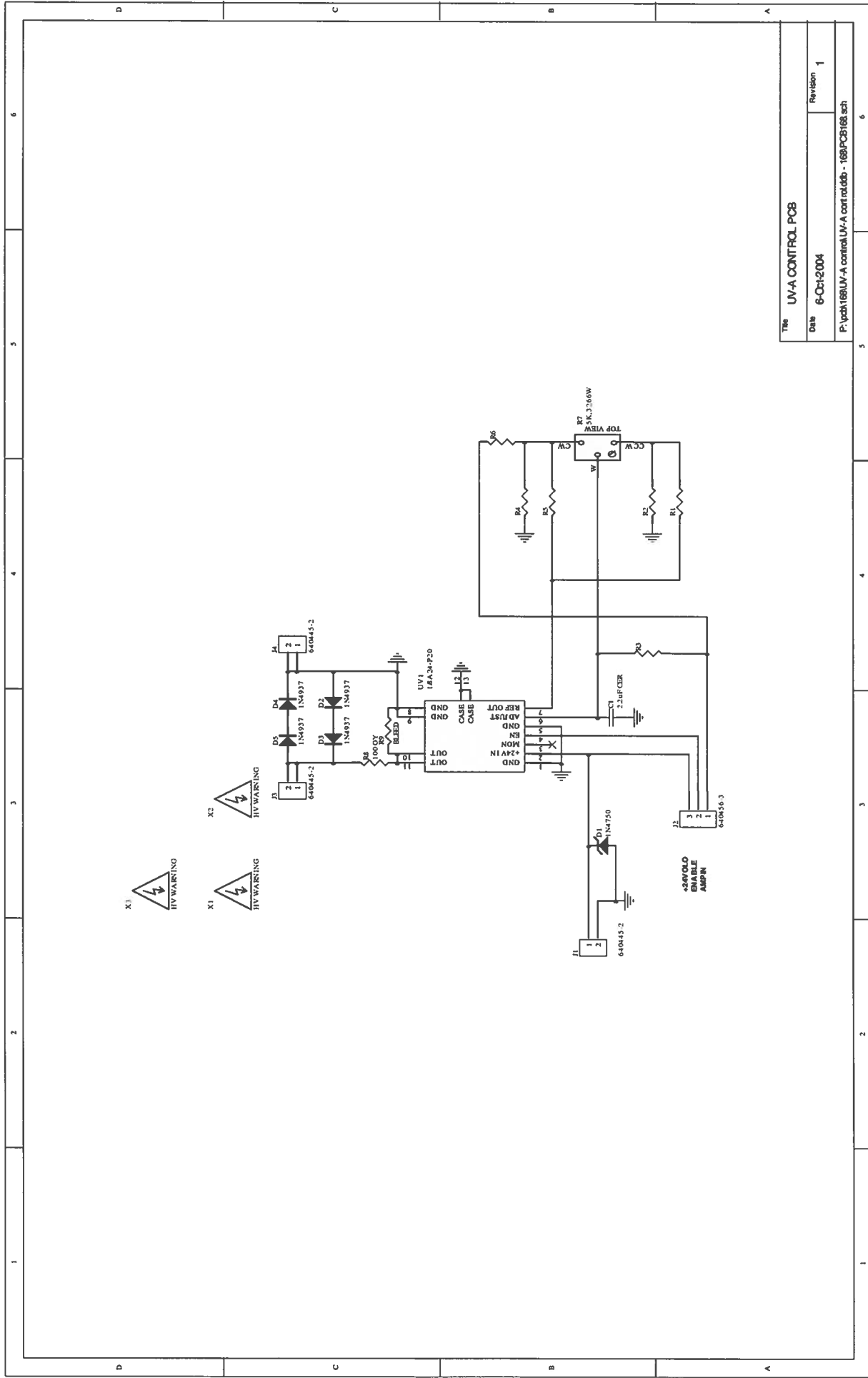

Title	UV-A CONTROL PCB
Date	6-Oct-2004
Revision	1
P:\pcb\168UV-A control\UV-A control.dwg - 168.PCB168.sch	

MAIN WIRING

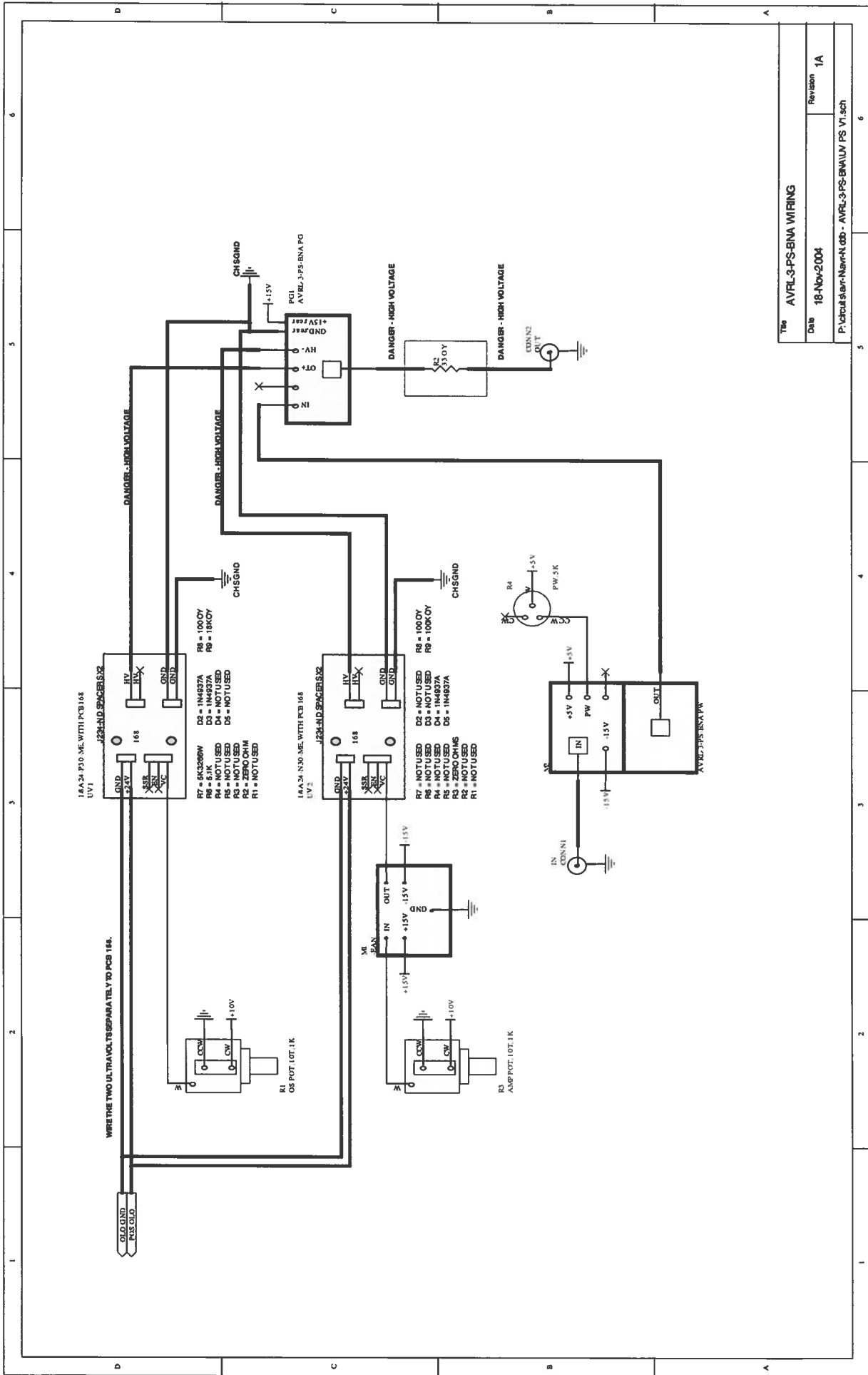

Title AVRL3-PS-BNA WIRING	
Doc 18-Nov-2004	Revision 1A
P:\circuit\Sam-Nann\A.dwg - AVRL3-PS-BNA\UV PS V1.sch	

NOV 18/04