



AVTECH ELECTROSYSTEMS LTD.

NANOSECOND WAVEFORM ELECTRONICS
SINCE 1975

P.O. BOX 265
OGDENSBURG, NY
U.S.A. 13669-0265
TEL: (315) 472-5270
FAX: (613) 226-2802

TEL: 1-800-265-6681
FAX: 1-800-561-1970

e-mail: info@avtechpulse.com
<http://www.avtechpulse.com/>

BOX 5120, LCD MERIVALE
OTTAWA, ONTARIO
CANADA K2C 3H4
TEL: (613) 226-5772
FAX: (613) 226-2802

INSTRUCTIONS

MODELS AVX-D-PS,
AVX-D-2-PS, AVX-D-3-PS

LOW JITTER
ANALOG
DELAY GENERATORS

SERIAL NUMBER: _____

WARRANTY

Avtech Electrosystems Ltd. warrants products of its manufacture to be free from defects in material and workmanship under conditions of normal use. If, within one year after delivery to the original owner, and after prepaid return by the original owner, this Avtech product is found to be defective, Avtech shall at its option repair or replace said defective item. This warranty does not apply to units which have been disassembled, modified or subjected to conditions exceeding the applicable specifications or ratings. This warranty is the extent of the obligation assumed by Avtech with respect to this product and no other warranty or guarantee is either expressed or implied.

TECHNICAL SUPPORT

Phone: 613-226-5772 or 1-800-265-6681

Fax: 613-226-2802 or 1-800-561-1970

E-mail: info@avtechpulse.com

World Wide Web: <http://www.avtechpulse.com>

TABLE OF CONTENTS

WARRANTY.....	2
TECHNICAL SUPPORT.....	2
TABLE OF CONTENTS.....	3
INTRODUCTION.....	4
OPTIONAL FEATURES.....	4
SPECIFICATIONS.....	5
EC DECLARATION OF CONFORMITY.....	6
INSTALLATION.....	7
VISUAL CHECK.....	7
POWER RATINGS.....	7
CONNECTION TO THE POWER SUPPLY.....	7
ENVIRONMENTAL CONDITIONS.....	7
FUSES.....	8
AC FUSE REPLACEMENT.....	8
DC FUSE REPLACEMENT.....	9
FUSE RATINGS.....	9
FRONT PANEL CONTROLS.....	10
REAR PANEL CONTROLS.....	12
GENERAL INFORMATION.....	13
BASIC TIMING CONTROL.....	13
"-ED" OPTION.....	13
MECHANICAL INFORMATION.....	14
TOP COVER REMOVAL.....	14
ELECTROMAGNETIC INTERFERENCE.....	14
MAINTENANCE.....	14
REGULAR MAINTENANCE.....	14
CLEANING.....	14
PERFORMANCE CHECKSHEET.....	15

INTRODUCTION

The three models in the AVX-D analog delay generator series feature low-jitter variable delays in the ranges of 30 ns to 150 ns (Model AVX-D-PS), 30 ns to 10 us (Model AVX-D-2-PS), and 1 us to 100 us (Model AVX-D-3-PS). Model AVX-D-PS offers a very low jitter of ± 10 ps. Model AVX-D-2-PS exhibits a jitter of ± 30 ps at the minimum delay setting, increasing to ± 300 ps at the maximum delay setting. The jitter for the longer-delay Model AVX-D-3-PS is specified as ± 300 ps.

All signals are TTL compatible and the output pulses will drive loads as low as 50 Ohms. The IN trigger pulse in all models is split into an output TRIG pulse (equal to the width of the IN pulse and delayed by < 20 ns) and an OUT pulse having a fixed width of about 250 ns. The delay between the leading edges of the IN and OUT pulses in Model AVX-D-PS (30 to 150 ns) is controlled by a ten-turn dial, while the delay in Models AVX-D-2-PS and AVX-D-3-PS (30 ns to 10 ms and 1 ms to 100 ms, respectively) is controlled by a ten-turn dial and a range switch.

This instrument is intended for use in research and development laboratories.

OPTIONAL FEATURES

The following options are available for the AVX-D-PS:

- ED option: Provides electronic control (0 to +10V) of the delay.
- SMA option: All connectors are SMA type, instead of BNC.

SPECIFICATIONS

Model:	AVX-D-PS	AVX-D-2-PS	AVX-D-3-PS
Delay range ¹ :	30 ns to 150 ns	30 ns to 10 us (3-position range switch)	1 us to 100 us (2-position range switch)
Jitter (Ext trig in to pulse out):	± 10 ps	± 30 ps to ± 300 ps max	± 300 ps
Output amplitude:	+ 5 V (TTL) will drive 50 Ohm loads		
Trigger required:	Modules and -PS units: +5 Volt, 50 to 500 ns (TTL)		
OUT pulse width:	250 ns		
Trig PW:	Equals input PW		
PRF:	0 to 1 MHz	0 to 1 MHz (50% maximum duty cycle)	0 to 50 kHz (50% maximum duty cycle)
Connectors:	Out: BNC, Trig: BNC, In: BNC		
Power requirement:	100 - 240 Volts, 50 - 60 Hz		
Dimensions: (H x W x D)	100 mm x 215 mm x 375 mm (3.9" x 8.5" x 14.8")		

EC DECLARATION OF CONFORMITY

We

Avtech Electrosystems Ltd.
P.O. Box 5120, LCD Merivale
Ottawa, Ontario
Canada K2C 3H4

declare that this pulse generator meets the intent of Directive 89/336/EEC for Electromagnetic Compatibility. Compliance pertains to the following specifications as listed in the official Journal of the European Communities:

EN 50081-1 Emission

EN 50082-1 Immunity

and that this pulse generator meets the intent of the Low Voltage Directive 72/23/EEC as amended by 93/68/EEC. Compliance pertains to the following specifications as listed in the official Journal of the European Communities:

EN 61010-1:2001 Safety requirements for electrical equipment for measurement, control, and laboratory use



INSTALLATION

VISUAL CHECK

After unpacking the instrument mainframe and the transformer module, examine to ensure that they have not been damaged in shipment. Visually inspect all connectors, knobs, and handles. Confirm that a power cord and an instrumentation manual (this manual), are with the instrument. If the instrument has been damaged, file a claim immediately with the company that transported the instrument.

POWER RATINGS

This instrument is intended to operate from 100 - 240 V, 50 - 60 Hz.

The maximum power consumption is 57 Watts. Please see the "FUSES" section for information about the appropriate AC and DC fuses.

This instrument is an "Installation Category II" instrument, intended for operation from a normal single-phase supply.

CONNECTION TO THE POWER SUPPLY

An IEC-320 three-pronged recessed male socket is provided on the back panel for AC power connection to the instrument. One end of the detachable power cord that is supplied with the instrument plugs into this socket. The other end of the detachable power cord plugs into the local mains supply. Use only the cable supplied with the instrument. The mains supply must be earthed, and the cable used to connect the instrument to the mains supply must provide an earth connection. (The supplied cable does this.)

ENVIRONMENTAL CONDITIONS

This instrument is intended for use under the following conditions:

- a) indoor use;
- b) altitude up to 2 000 m;
- c) temperature 5 °C to 40 °C;
- d) maximum relative humidity 80 % for temperatures up to 31 °C decreasing linearly to 50 % relative humidity at 40 °C;
- e) Mains supply voltage fluctuations up to ± 10 % of the nominal voltage;
- f) no pollution or only dry, non-conductive pollution.

FUSES

This instrument contains four fuses. All are accessible from the rear-panel. Two protect the AC prime power input, and two protect the internal DC power supplies. The locations of the fuses on the rear panel are shown in the figure below:

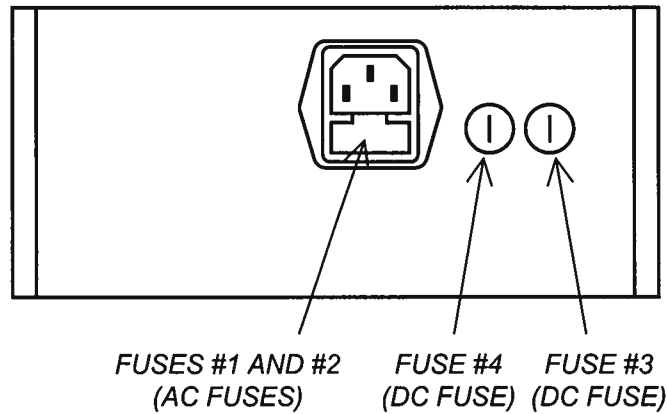

AC FUSE REPLACEMENT

To physically access the AC fuses, the power cord must be detached from the rear panel of the instrument. The fuse drawer may then be extracted using a small flat-head screwdriver, as shown below:

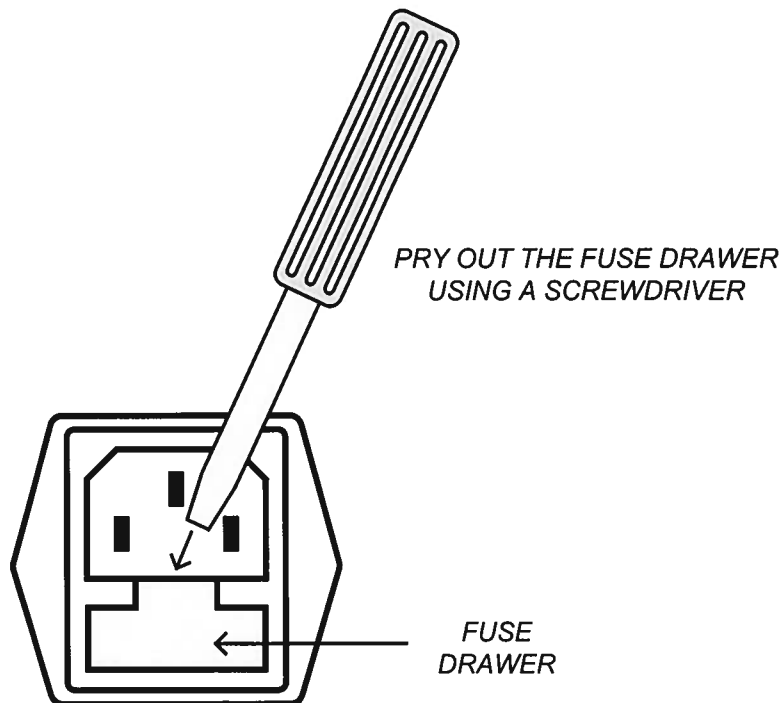

DC FUSE REPLACEMENT

The DC fuses may be replaced by inserting the tip of a flat-head screwdriver into the fuse holder slot, and rotating the slot counter-clockwise. The fuse and its carrier will then pop out.

FUSE RATINGS

The following table lists the required fuses:

Fuses	Mains Voltage	Rating	Case Size	Manufacturer's Part Number (Wickmann)	Distributor's Part Number (Digi-Key)
#1, #2 (AC)	115 V	0.25A, 250V, Time-Delay	5 x 20 mm	1950250000	WK5035-ND
	230 V	0.25A, 250V, Time-Delay	5 x 20 mm	1950250000	WK5035-ND
#3 (DC)	115/230V	0.25A, 250V, Time-Delay	5 x 20 mm	1950250000	WK5035-ND
#4 (DC)	115/230V	Not used. A spare 0.25A fuse is installed in this holder.			

The fuse manufacturer is Wickmann (<http://www.wickmann.com/>).

Replacement fuses may be easily obtained from Digi-Key (<http://www.digikey.com/>) and other distributors.

FRONT PANEL CONTROLS

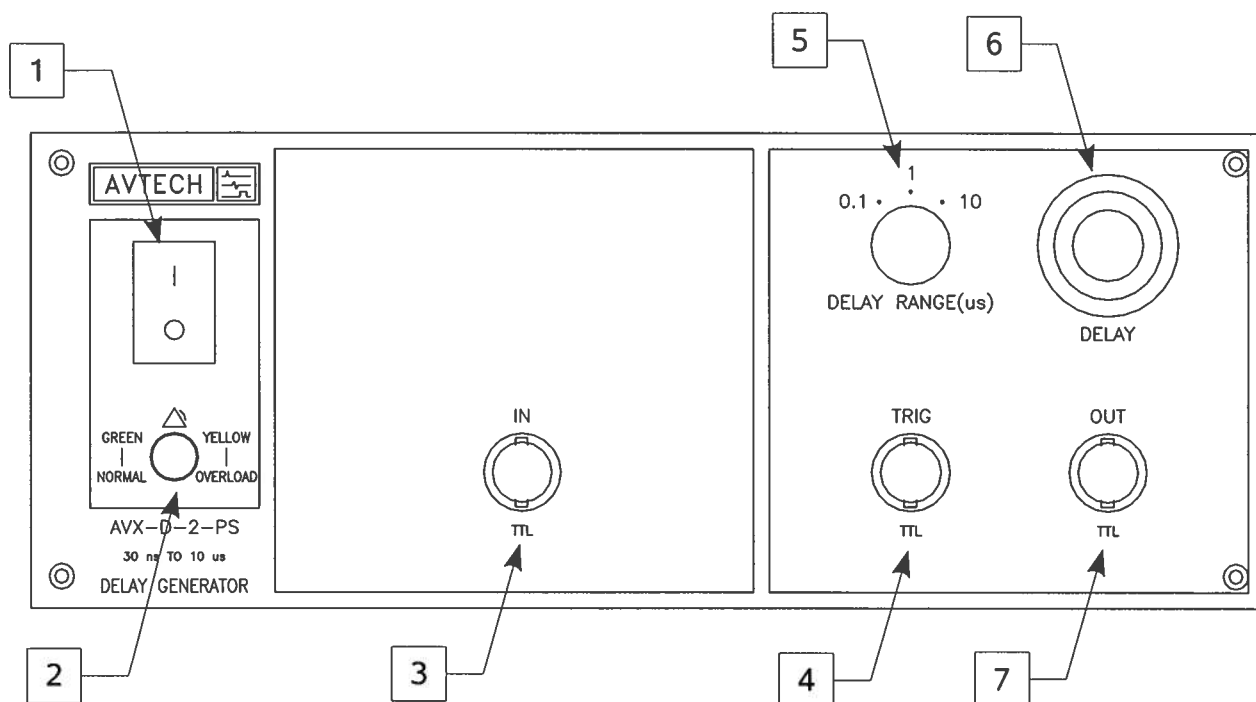

1. **POWER Switch.** This is the main power switch. When turning the instrument on, there may be a delay of several seconds before the instrument appears to respond.
2. **OVERLOAD Indicator.** When the instrument is powered, this indicator is normally green, indicating normal operation. If this indicator is yellow, an internal automatic overload protection circuit has been tripped. If the unit is overloaded (by operating at an exceedingly high duty cycle or by operating into a very low impedance), the protective circuit will disable the output of the instrument and turn the indicator light yellow. The light will stay yellow (i.e. output disabled) for about 5 seconds after which the instrument will attempt to re-enable the output (i.e. light green) for about 1 second. If the overload condition persists, the output will be disabled again (i.e. light yellow) for another 5 seconds. If the overload condition has been removed, the instrument will resume normal operation.

This overload indicator may flash yellow briefly at start-up. This is not a cause for concern.

3. **IN Connector.** The TTL-level input signal (i.e. logic low = 0V, logic high = +3 to +5V) is applied to this BNC connector. The input pulse width must be 50 ns or wider. The input impedance of this input is 1 k Ω .

Depending on the length of cable attached to this input, and the source driving it, it may be desirable to add a coaxial 50 Ohm terminator to this input to provide a proper transmission line termination. The Pasternack (www.pasternack.com) PE6008-50 BNC feed-thru 50 Ohm terminator is suggested for this purpose. For systems using SMA connectors, the PE6026 SMA feed-thru 50 Ohm terminator is

suggested.

4. TRIG Connector. A replica of the IN pulse appears on this output. This TTL-level output will drive loads of 50Ω or greater. The output pulse width is approximately equal to the input pulse width. The TRIG output is delayed by a fixed amount (< 20 ns) relative to the IN pulse.
5. DELAY Range Switch (AVX-D-2-PS and AVX-D-3-PS only). This range switch, in conjunction with the delay vernier (item 5) controls the delay of the OUT pulse relative to the IN pulse. The upper end of each range is marked on the switch positions.

For the AVX-D-2-PS, the ranges are:

30 ns - 100 ns
100 ns - 1 us
1 us - 10 us

For the AVX-D-3-PS, the ranges are:

1 us - 10 us
10 us - 100 us

6. DELAY Vernier. This controls the delay of the OUT pulse relative to the IN pulse, in conjunction with the range switch (item 4, if present).
7. OUT Connector. This is the main output. The TTL-level pulses (i.e. logic low = 0V, logic high = +3 to +5V) are delayed relative to the input pulses on the IN connector (item 2) by a time set by the DELAY controls (items 4 and 5).

The output pulse width is fixed at approximately 250 ns. This output will drive loads of 50Ω or greater.

REAR PANEL CONTROLS

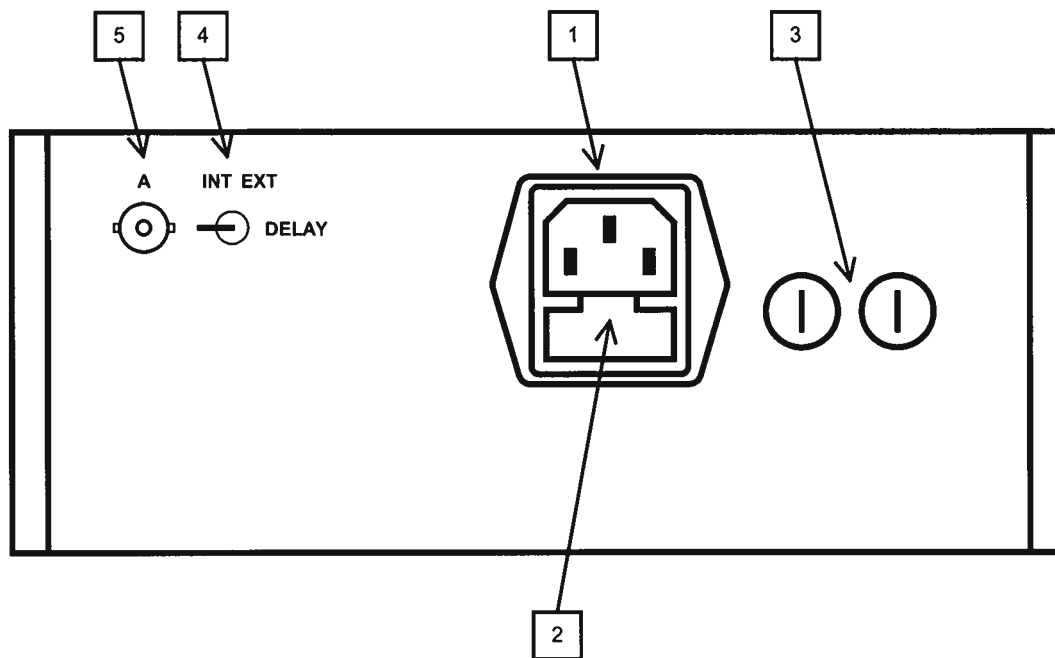

1.AC POWER INPUT. An IEC-320 C14 three-pronged recessed male socket is provided on the back panel for AC power connection to the instrument. One end of the detachable power cord that is supplied with the instrument plugs into this socket.

2.AC FUSE DRAWER. The two fuses that protect the AC input are located in this drawer. Please see the “FUSES” section of this manual for more information.

3.DC FUSES. These two fuses protect the internal DC power supplies. Please see the “FUSES” sections of this manual for more information.

4.-ED Switch (Models With “-ED” Option Only). When this switch is in the “INT” position, the delay is controlled by the front panel controls. When this switch is in the “EXT” position, the voltage applied to the -ED Connector controls the delay.

5.-ED Connector (Models With “-ED” Option Only). When the -ED switch is in the “EXT” position, the voltage applied to this connector controls the delay. A voltage of zero corresponds to minimum delay, and +10V corresponds to maximum delay. The input impedance is approximately 10k Ω .

GENERAL INFORMATION

BASIC TIMING CONTROL

This instrument has one pulse input and two pulse outputs.

The TRIG output is delayed by a fixed amount (< 20 ns) relative to the IN pulse. The output pulse width is approximately equal to the input pulse width.

The OUT output is delayed relative to the input pulses on the IN connector by a time set by the DELAY controls. The output pulse width is fixed at approximately 250 ns.

Both outputs will drive loads of 50Ω or greater. All inputs and outputs operate at standard TTL logic levels (i.e. logic low = 0V, logic high = +3 to +5V).

The basic input and output waveforms are illustrated below:

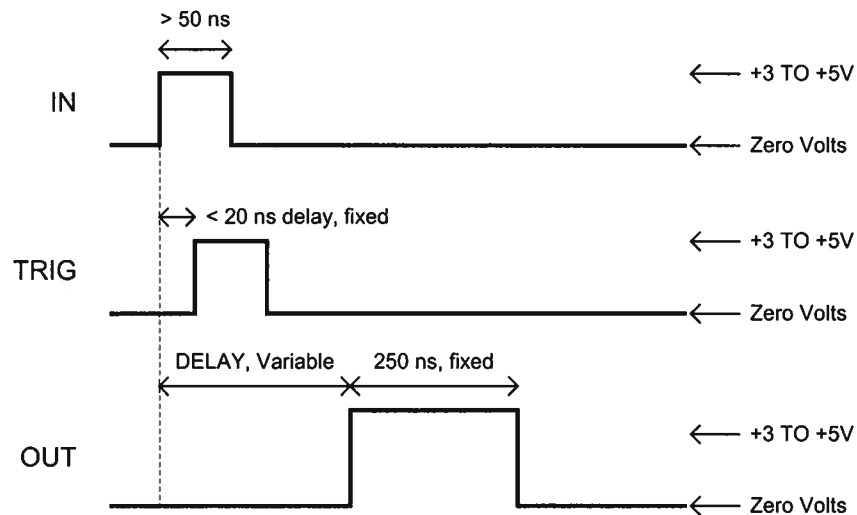

Basic Operation

"-ED" OPTION

The IN-to-OUT delay on models with the "-ED" option can be controlled by the standard front-panel controls or by a DC voltage applied to a rear-panel connector. When the -ED switch is in the "EXT" position, the voltage applied to this connector controls the delay. A voltage of zero corresponds to minimum delay, and +10V corresponds to maximum delay. The input impedance is approximately $10k\Omega$.

MECHANICAL INFORMATION

TOP COVER REMOVAL

If necessary, the interior of the instrument may be accessed by removing the four Phillips screws on the top panel. With the four screws removed, the top cover may be slid back (and off).

Always disconnect the power cord before opening the instrument.

There are no user-adjustable internal circuits. For repairs other than fuse replacement, please contact Avtech (info@avtechpulse.com) to arrange for the instrument to be returned to the factory for repair.

 Caution: High voltages are present inside the instrument during normal operation. Do not operate the instrument with the cover removed.

ELECTROMAGNETIC INTERFERENCE

To prevent electromagnetic interference with other equipment, all used outputs should be connected to shielded 50Ω loads using shielded 50Ω coaxial cables. Unused outputs should be terminated with shielded 50Ω coaxial terminators or with shielded coaxial dust caps, to prevent unintentional electromagnetic radiation. All cords and cables should be less than 3m in length.

MAINTENANCE

REGULAR MAINTENANCE

This instrument does not require any regular maintenance.

On occasion, one or more of the four rear-panel fuses may require replacement. All fuses can be accessed from the rear panel. See the “FUSES” section for details.

CLEANING

If desired, the interior of the instrument may be cleaned using compressed air to dislodge any accumulated dust. (See the “TOP COVER REMOVAL” section for instructions on accessing the interior.) No other cleaning is recommended.

Nov. 4 / 03